

DESCRIPTION

This is a high radiance 850 nm GaAlAs IR LED optimized for fiber optic applications requiring high output power and a fast response time.

FEATURES

- High Coupled Power
- High Electrical Bandwidth/ Fast response time
- High Reliability/ Hermetic Package

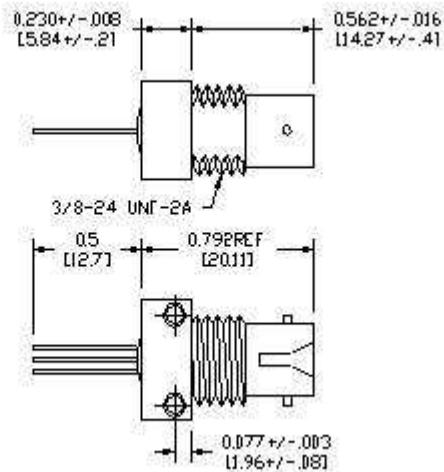
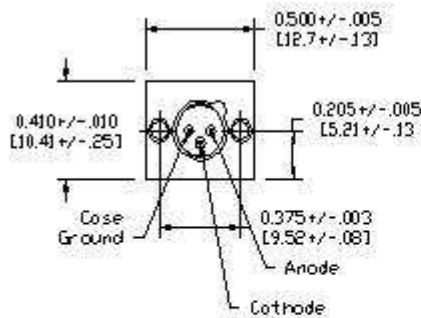

ABSOLUTE MAXIMUM RATINGS

- Storage temperature..... -55°C to +125°C
- Case operating temperature..... -40°C to +85°C
- Lead solder temperature..... 260°C, 10 seconds
- Continuous forward current..... 100 mA
- Reverse Voltage..... 1 Volt

OUTLINE DIMENSIONS

Tolerances are +/- 0.005 inches, except as noted
 The case is electrically isolated from the pins

PARAMETER	TEST CONDITION	SYMBOL	MIN	TYP	MAX	UNIT
Forward Voltage	I _f = 100 mA	V _f		1.3	2.0	Volts
Reverse Voltage	I _r = 10 μA	BVR	1.0	5.0		Volts
Capacitance	V _r = 0 V, f = 1 MHz	C		70		pF
Fiber Coupled Power	I _f = 100 mA, 50 μm Core dia, .21 NA	P _{oc}	25	30		μW
Fiber Coupled Power	I _f = 100 mA, 62.5 μm Core dia, .28 NA	P _{oc}	125	200		μW
Total Optical Power	I _f = 100 mA	P _{out}		3.5		mW
Response Time	10%-90%, 1V Prebias	t _r		4	10	nsec
	I _f = 100 mA	t _f		6	10	nsec
Peak Wavelength	I _f = 100 mA	λ _p	810	850	885	nm
Spectral Bandwidth	I _f = 100 mA	Δλ		50		nm
Electrical Bandwidth	I _f = 100 mA	BWE		85		MHz

ELECTRO-OPTICAL CHARACTERISTICS (Case T = 25°C)