

DESCRIPTION

This is a high radiance InGaAs IR LED optimized for fiber optic applications requiring high power and a fast response time.

FEATURES

- 12 Degree Half Angle of light emission
- High Electrical Bandwidth/ Fast response time
- High Reliability
- Hermetic Package

ABSOLUTE MAXIMUM RATINGS

- Storage temperature..... -65°C to +125°C
- Case operating temperature -40°C to +85°C
- Lead solder temperature.... 260°C, 10 seconds
- Continuous forward current..... 100 mA
- Reverse Voltage..... 3 Volts

OUTLINE DIMENSIONS

Tolerances are +/- 0.005 inches, except as noted

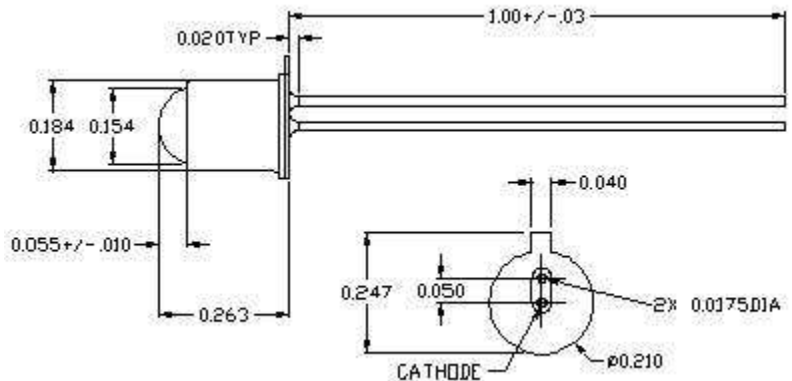

Pinout

1. Cathode
2. Anode

The case is electrically isolated from the pins

ELECTRO-OPTICAL CHARACTERISTICS (Case T = 25°C)

PARAMETER	TEST CONDITION	SYMBOL	MIN	TYP	MAX	UNIT
Forward Voltage	I _f = 100 mA	V _f		0.8	2.0	Volts
Reverse Voltage	I _r = 10 μA	BVR	3.0			Volts
Half Angle at Half Power		θ _{1/2}		6	12	DEG
Capacitance	V _r = 0 V, f = 1 MHz	C		70		pF
Total Optical Power	I _f = 100 mA	P _{out}	0.3	0.8		mW
Response Time	10%-90%, 1V Prebias I _f = 100 mA	t _r		6	12	nsec
		t _f		6	12	nsec
Peak Wavelength	I _f = 100 mA	λ _p	1280	1310	1350	nm
Spectral Bandwidth	I _f = 100 mA	Δλ		145		nm
Electrical Bandwidth	I _f = 100 mA	BWE		85		MHz