

KEY PARAMETERS

V_{DRM}	4500V
$I_{T(AV)}$	1670A
I_{TSM}	37000A
di_T/dt	22000A/ μ s

APPLICATIONS

- Pulse Power
- Crowbars
- Ignitron Replacement

FEATURES

- Double Side Cooling
- Fast Turn-on
- Low Turn-on Losses

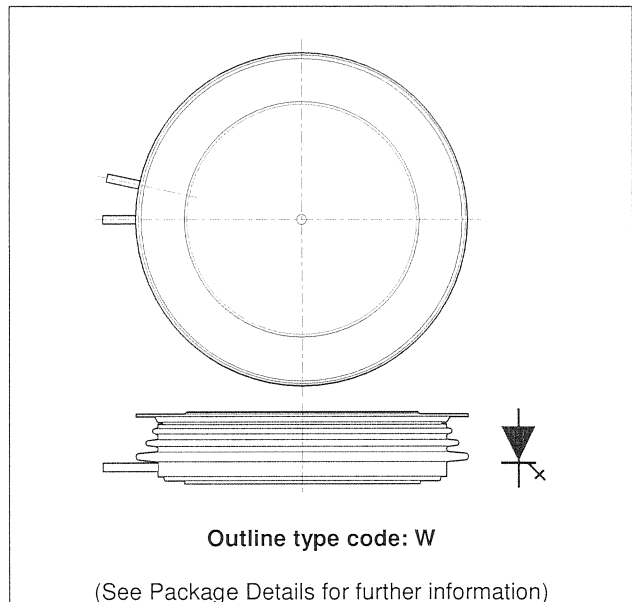

Fig. 1 Package outline

VOLTAGE RATINGS

Type Number	Repetitive Peak Off-state Voltage V_{DRM} (V)	Repetitive Peak Reverse Voltage V_{RRM} (V)	Conditions
PT85QWx45	4500	16	$T_{vj} = 0^\circ$ to 125° C, $I_{DRM} = I_{RRM} = 50$ mA, $V_{DRM}, V_{RRM} t_p = 10$ ms

CURRENT RATINGS

Symbol	Parameter	Conditions	Max.	Units
Double Side Cooled				
$I_{T(AV)}$	Mean on-state current	$T_{case} = 80^\circ$ C, Half sine 50Hz resistive load	1670	A
$I_{T(RMS)}$	RMS on-state current	$T_{HS} = 80^\circ$ C	1225	A

SURGE RATINGS

Symbol	Parameter	Test Conditions	Max.	Units
I_{TSM}	Surge (non repetitive) on-state current	10ms half sine. $T_{case} = 125^{\circ}C$	29.6	kA
I^2t	I^2t for fusing	$V_R = 50\% V_{RRM} - 1/4$ sine	4.38	MA ² s
I_{TSM}	Surge (non repetitive) on-state current	10ms half sine; $T_{case} = 125^{\circ}C$	37	kA
I^2t	I^2t for fusing	$V_R = 0$	6.85	MA ² s

THERMAL AND MECHANICAL RATINGS

Symbol	Parameter	Conditions	Min.	Max.	Units
$R_{th(j-c)}$	Thermal resistance – junction to case	Double side cooled	-	0.01	$^{\circ}C/W$
$R_{th(c-h)}$	Thermal resistance – case to heatsink	Clamping force 40kN with mounting compound	-	0.001	$^{\circ}C/W$
T_{vj}	Virtual junction temperature	On-state (conducting)	-	135	$^{\circ}C$
		Reverse (blocking)	-	125	$^{\circ}C$
T_{stg}	Rate of rise of reverse gate current		-55	125	$^{\circ}C$
-	Clamping force		36.0	44.0	kN

DYNAMIC CHARACTERISTICS

Symbol	Parameter	Conditions	Min.	Max.	Units
I_{RRM}/I_{DRM}	Peak reverse and off-state current	At V_{RRM}/V_{DRM} $T_{case} = 125^{\circ}C$, $V_{RG} = 0V$	-	250	mA
dV/dt	Maximum linear rate of rise of off-state voltage	To 66% V_{DRM} ; $R_{GK} \leq 1.5\Omega$, $T_j = 125^{\circ}C$	-	200	V/ μ s
dI/dt	Rate of rise of on-state current	From 67% V_{DRM} to 90kA Gate source 130A $t_r = 1.5\mu$ s, $T_j = 125^{\circ}C$	-	22	kA/ μ s
$V_{T(TO)}$	Threshold voltage	At $T_{vj} = 125^{\circ}C$	-	1.45	V
r_T	On-state slope resistance	At $T_{vj} = 125^{\circ}C$	-	0.3	m Ω

GATE TRIGGER CHARACTERISTICS AND RATINGS

Symbol	Parameter	Conditions	Min.	Max.	Units
V_{GT}	Gate trigger voltage	$V_{DRM} = 5V$, $T_{case} = 25^{\circ}C$	1.0	4.0	V
I_{GT}	Gate trigger current	$V_{DRM} = 5V$, $T_{case} = 25^{\circ}C$	-	1.5	A

ORDERING INFORMATION

PT Pulse Power Thyristor
 85Q Device type
 W package outline type code
 x lead length (see table, right)
 45 Voltage x 100

Lead length (x)		
O	No lead	
C	8"	200mm
D	10"	250mm
E	12"	300mm
F	16"	400mm
G	18"	450mm
H	20"	500mm
J	24"	600mm
K	30"	750mm
L	40"	1000mm

CURVES

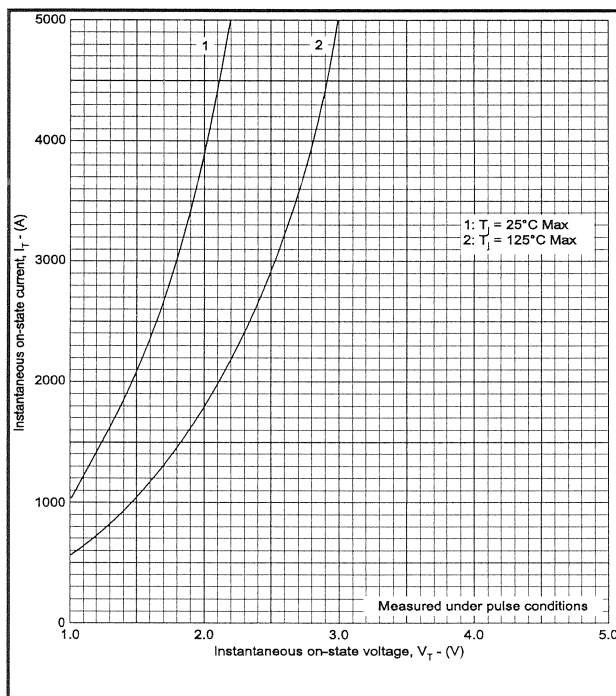

Fig.2 Maximum (limit) on-state characteristics

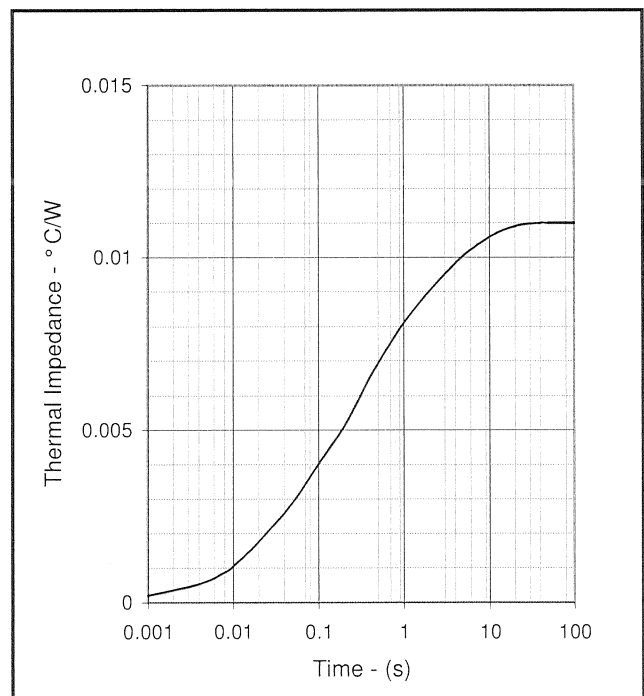

Fig.3 Maximum (limit) transient thermal impedance-double side cooled

PACKAGE DETAILS

For further package information, please contact Customer Services. All dimensions in mm, unless stated otherwise. DO NOT SCALE.

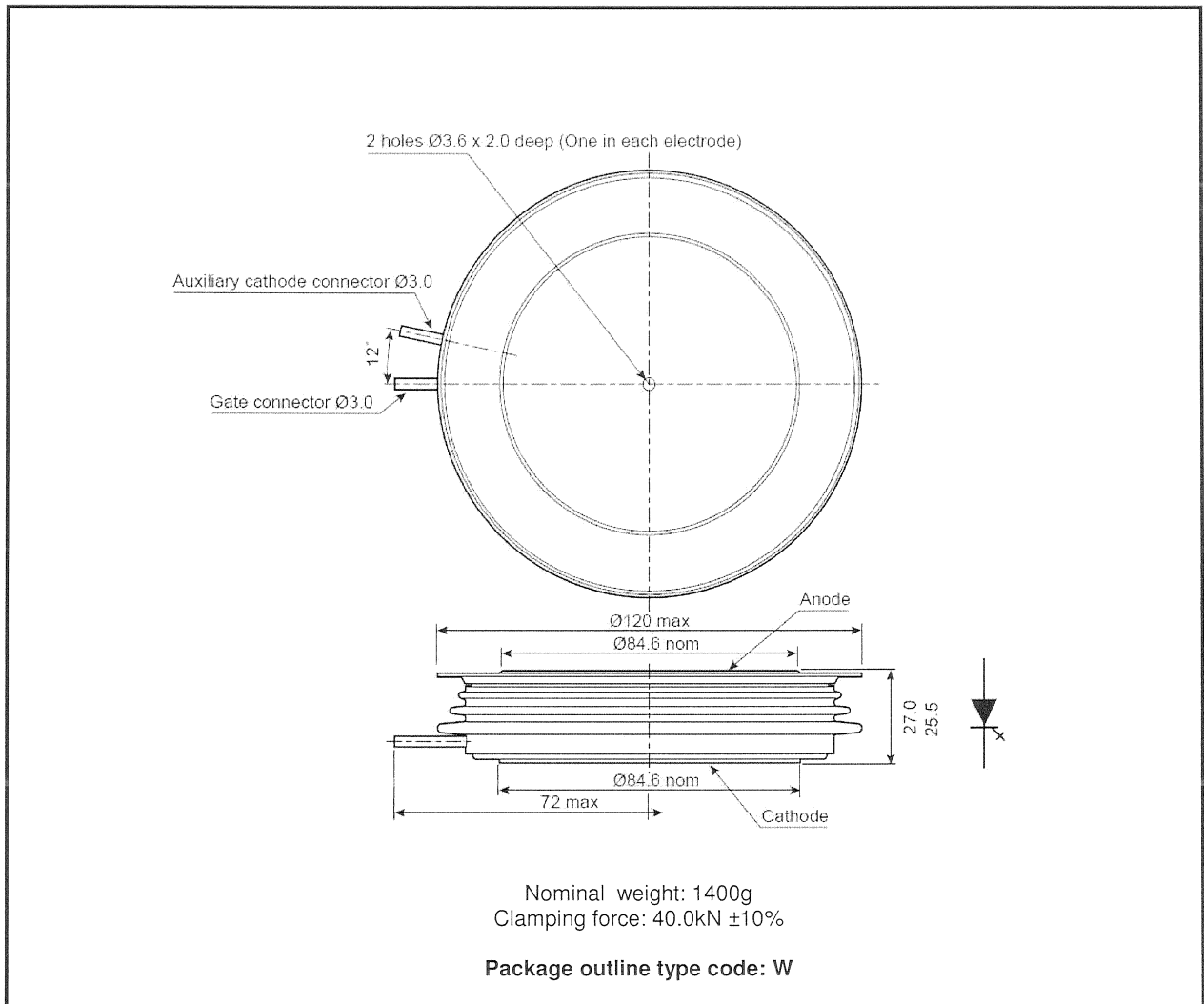

Fig.4 Package outline

IMPORTANT INFORMATION:

The products and data in this publication are intended for use by appropriately trained technical personnel.

Due to the diversity of product applications, the information contained herein is provided as a guide only and does not constitute any guarantee of suitability for use in a specific application. The user must evaluate the suitability of the product and the completeness of the product data for the application. The user is responsible for product selection and ensuring all safety and any warning requirements are met. Should additional product information be needed please contact Customer Service.

This publication is an uncontrolled document and is subject to change without notice. When referring to it, please ensure that it is the most up to date version and has not been superseded.

The products are not intended for use in applications where a failure or malfunction may cause loss of life, injury or damage to property. The user must ensure that appropriate safety precautions are taken to prevent or mitigate the consequences of a product failure or malfunction.

The products must not be touched when operating because there is a danger of electrocution or severe burning. Always use protective safety equipment such as appropriate shields for the product and wear safety glasses. Even when disconnected any electric charge remaining in the product must be discharged and allowed to cool before safe handling using protective gloves.

Extended exposure outside the product ratings may affect reliability leading to premature product failure. Use outside the product ratings is likely to cause permanent damage to the product. In extreme conditions, as with all semiconductors, this may include potentially hazardous rupture, a large current to flow or high voltage arcing, resulting in fire or explosion. Appropriate application design and safety precautions should always be followed to protect persons and property.

Product Status & Product Ordering:

We annotate datasheets in the top right hand corner of the front page, to indicate product status if it is not yet fully approved for production. The annotations are as follows:-

Target Information: This is the most tentative form of information and represents a very preliminary specification. No actual design work on the product has been started.

Preliminary Information: The product design is complete and final characterisation for volume production is in progress. The datasheet represents the product as it is now understood but details may change.

No Annotation: The product has been approved for production and unless otherwise notified by Dynex any product ordered will be supplied to the **current version of the data sheet prevailing at the time of our order acknowledgement.**

All products and materials are sold and services provided subject to the Company's conditions of sale, which are available on request.

All brand names and product names used in this publication are trademarks, registered trademarks or trade names of their respective owners.

HEADQUARTERS OPERATIONS

DYNEX SEMICONDUCTOR LIMITED
Doddington Road, Lincoln, Lincolnshire, LN6 3LF
United Kingdom.
Phone: +44 (0) 1522 500500
Fax: +44 (0) 1522 500550
Web: <http://www.dynexsemi.com>

CUSTOMER SERVICE

Phone: +44 (0) 1522 502753 / 502901
Fax: +44 (0) 1522 500020
e-mail: power_solutions@dynexsemi.com