

FEATURES

- Double Side Cooling
- Fast Turn-on characteristics

APPLICATIONS

- Fast capacitor discharge
- Pulse power Applications
- Fast crowbar application

VOLTAGE RATINGS

Part and Ordering Number	Repetitive Peak Off-state Voltage V_{DRM} V	Repetitive Peak Reverse Voltages V_{RRM} V
ACR300SG33	3300 $T_{vj} = -40^{\circ}\text{C to } 125^{\circ}\text{C}$, $I_{DRM} = 50\text{mA}$, $V_{DRM}, t_p = 10\text{ms}$, $V_{DSM} = V_{DRM} + 100\text{V}$	20 $T_{vj} = -40^{\circ}\text{C to } 125^{\circ}\text{C}$, $I_{RRM} = 50\text{mA}$, $V_{RRM}, t_p = 10\text{ms}$, $V_{RSM} = V_{RRM} + 100\text{V}$

Lower voltage grades available.

KEY PARAMETERS

V_{DRM}	3300V
$I_{T(AV)}$	493A
I_{TSM}	6500A
dV/dt^*	3000V/μs
dI/dt	2000A/μs
t_{on}	400ns

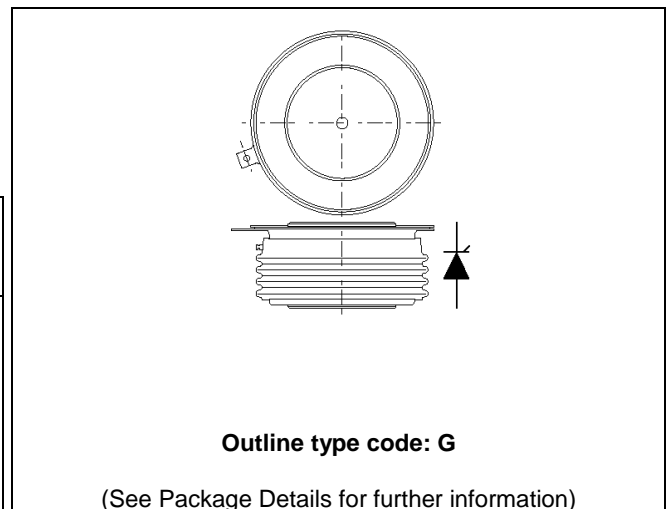

Fig. 1 Package outline

ORDERING INFORMATION

When ordering, select the required part number shown in the Voltage Ratings selection table.

For example:

ACR300SG33

Note: Please use the complete part number when ordering and quote this number in any future correspondence relating to your order.

CURRENT RATINGS

$T_{case} = 80^{\circ}\text{C}$ unless stated otherwise

Symbol	Parameter	Test Conditions	Max.	Units
Double Side Cooled				
$I_{T(AV)}$	Mean on-state current	Half wave resistive load	493	A
$I_{T(RMS)}$	RMS value	-	774	A
I_T	Continuous (direct) on-state current	-	630	A
Single Side Cooled (Anode side)				
$I_{T(AV)}$	Mean on-state current	Half wave resistive load	343	A
$I_{T(RMS)}$	RMS value	-	539	A
I_T	Continuous (direct) on-state current	-	420	A

SURGE RATINGS

Symbol	Parameter	Test Conditions	Max.	Units
I_{TSM}	Surge (non-repetitive) on-state current	10ms half sine, $T_{case} = 125^{\circ}\text{C}$	6.5	kA
I^2t	I^2t for fusing	$V_R = 0$	211	kA^2s

THERMAL AND MECHANICAL RATINGS

Symbol	Parameter	Test Conditions	Min.	Max.	Units	
$R_{th(j-c)}$	Thermal resistance – junction to case	Double side cooled	DC	-	0.042	$^{\circ}\text{C/W}$
		Single side cooled	Anode DC	-	0.070	$^{\circ}\text{C/W}$
			Cathode DC	-	0.092	$^{\circ}\text{C/W}$
$R_{th(c-h)}$	Thermal resistance – case to heatsink	Clamping force $7.0 \pm 1\text{kN}$ (with mounting compound)	Double side	-	0.018	$^{\circ}\text{C/W}$
			Single side	-	.036	$^{\circ}\text{C/W}$
T_{vj}	Virtual junction temperature	On-state (conducting)	-	135	$^{\circ}\text{C}$	
		Reverse (blocking)	-	125	$^{\circ}\text{C}$	
T_{stg}	Storage temperature range		-55	125	$^{\circ}\text{C}$	
F_m	Clamping force		6	8	kN	

DYNAMIC CHARACTERISTICS

Symbol	Parameter	Test Conditions	Min.	Max.	Units
V_{TM}	Maximum on-state voltage	At 1000A peak, $T_{case} = 25^{\circ}C$	-	2.0	V
I_{RRM}/I_{DRM}	Peak reverse and off-state current	At V_{RRM}/V_{DRM} , $T_{case} = 125^{\circ}C$	-	60	mA
dV/dt	Max. linear rate of rise of off-state voltage	To $V_D = 2000V$, $T_j = 125^{\circ}C$, gate open	3000		V/ μ s
di/dt	Rate of rise of on-state current	From V_{DRM} to 125A Gate source 30V, 10 Ω , Gate rise time $t_r \leq 100ns$, $T_j = 125^{\circ}C$		2000	A/ μ s
$V_{T(TO)}$	Threshold voltage	$T_{vj} = 125^{\circ}C$	-	1.19	V
r_T	On-state slope resistance	$T_{vj} = 125^{\circ}C$	-	0.81	m Ω
t_{gd}	Delay time	$V_D = 3000V$, gate source 30V, 10 Ω Gate rise time $t_r = 100ns$, $T_j = 25^{\circ}C$	-	350	ns
t_r	Rise time	As defined in Figure 2 $T_j = 25^{\circ}C$		50	ns
I_L	Latching current	$T_j = 25^{\circ}C$, $V_D = 5V$	-	600	mA
I_H	Holding current	$T_j = 25^{\circ}C$, $R_{G-K} = \infty$, $I_{TM} = 500A$, $I_T = 5A$	-	300	mA

GATE TRIGGER CHARACTERISTICS AND RATINGS

Symbol	Parameter	Test Conditions	Max.	Units
V_{GT}	Gate trigger voltage	$V_{DWM} = 12V$, $R_L = 6\Omega$ $T_{case} = 25^{\circ}C$	5	V
I_{GT}	Gate trigger current	$V_{DWM} = 12V$, $R_L = 6\Omega$ $T_{case} = 125^{\circ}C$	500	mA
V_{FGM}	Peak forward gate voltage		40	V
V_{RGM}	Peak reverse gate voltage		10	V
I_{FGM}	Peak forward gate current		20	A
P_{GM}	Peak gate power		40	W
$P_{G(AV)}$	Average gate power	Average time 10ms max	10	W

CURRENT CARRYING CAPABILITY AFTER DEVICE SHORT CIRCUIT

In the event of a chip short-circuit due to excess anode-cathode voltage, the device will handle a high continuous RMS fault current without significant damage. Rating details are as follows:

Continuous current capability: 300A RMS, ac or dc in either direction.

Conditions:

1. Device single or double side cooled.
2. Case temperature to be held at 200°C or less.
3. A suitable high temperature clamp to be used.
4. Chip fault site resistance assumed to be $3m\Omega \pm 10\%$.

CURVES

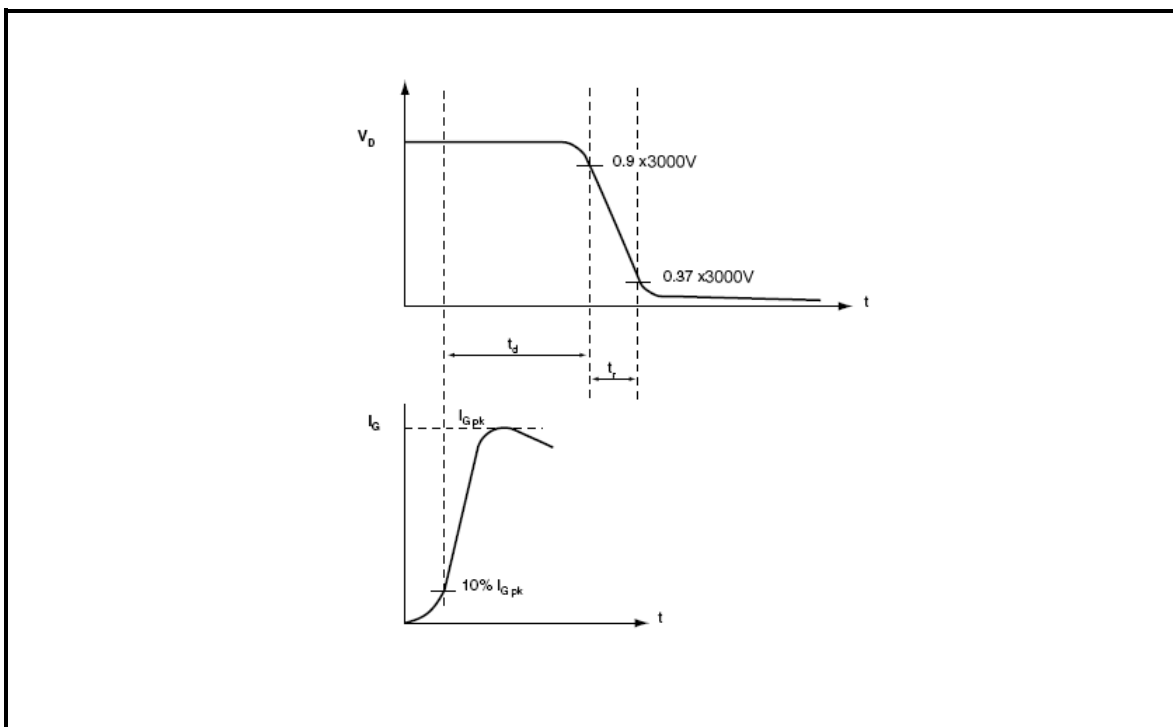

Fig.2 Turn-on time measurement

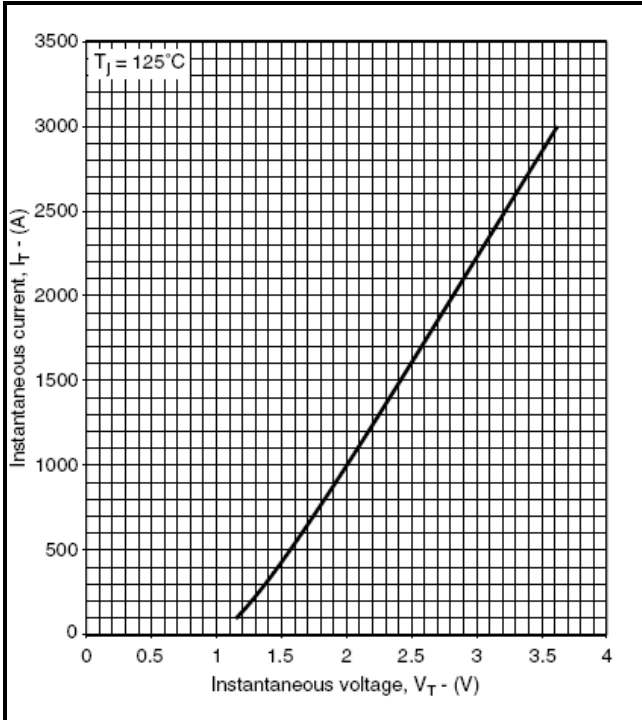

Fig.3 On-state Characteristics

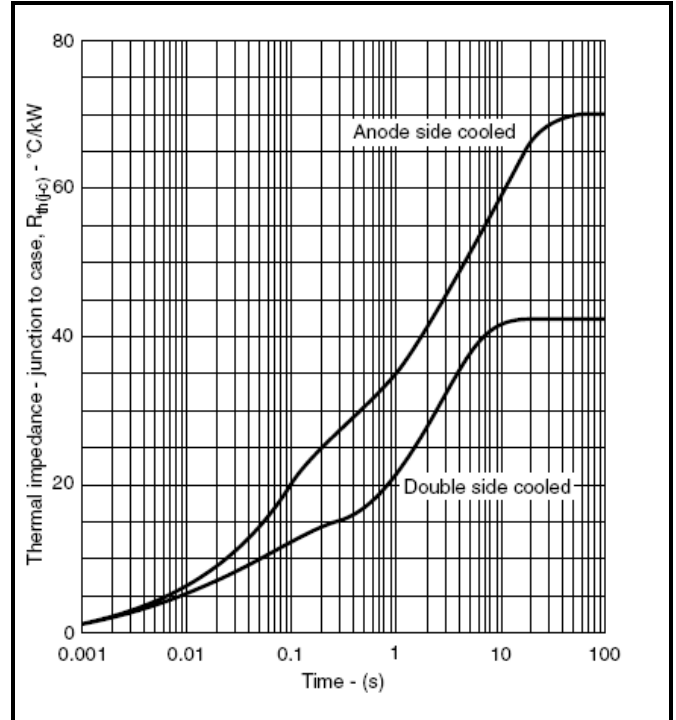

Fig.4 Transient thermal impedance- junction to case

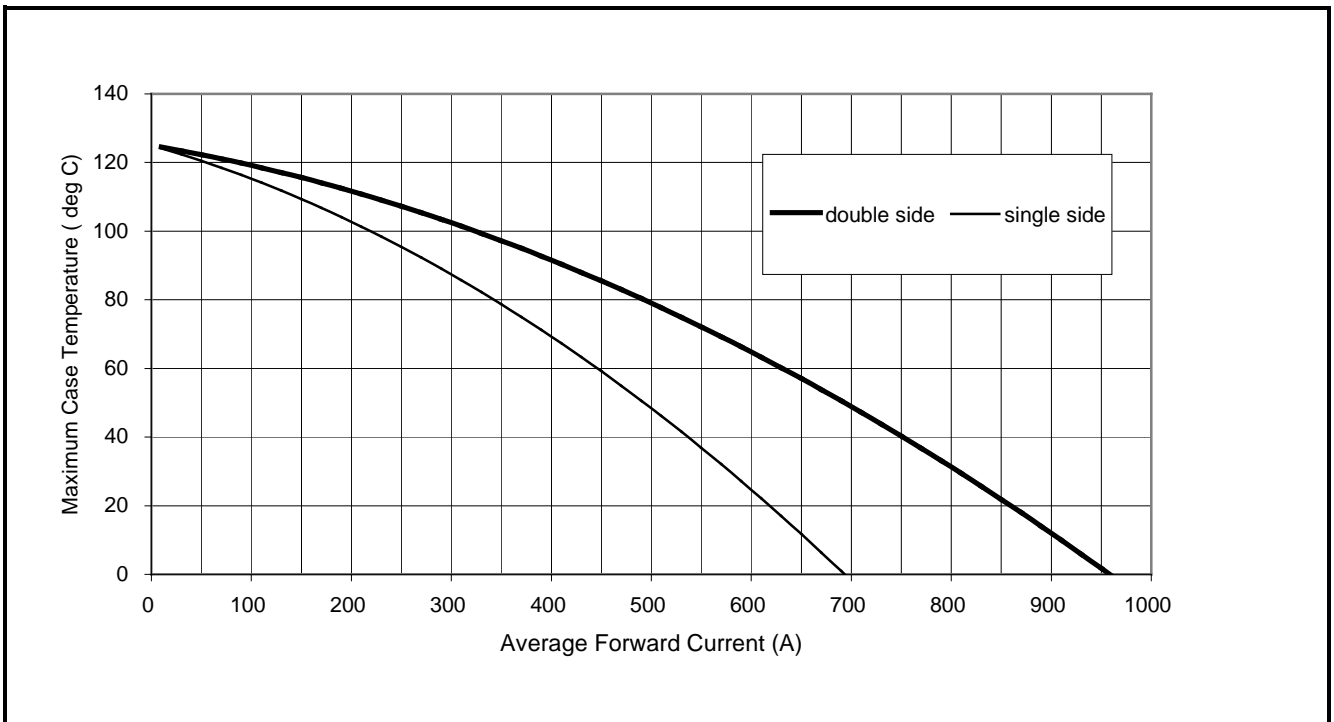

Fig.5 Average current rating vs temperature

PACKAGE DETAILS

For further package information, please contact Customer Services. All dimensions in mm, unless stated otherwise. DO NOT SCALE.

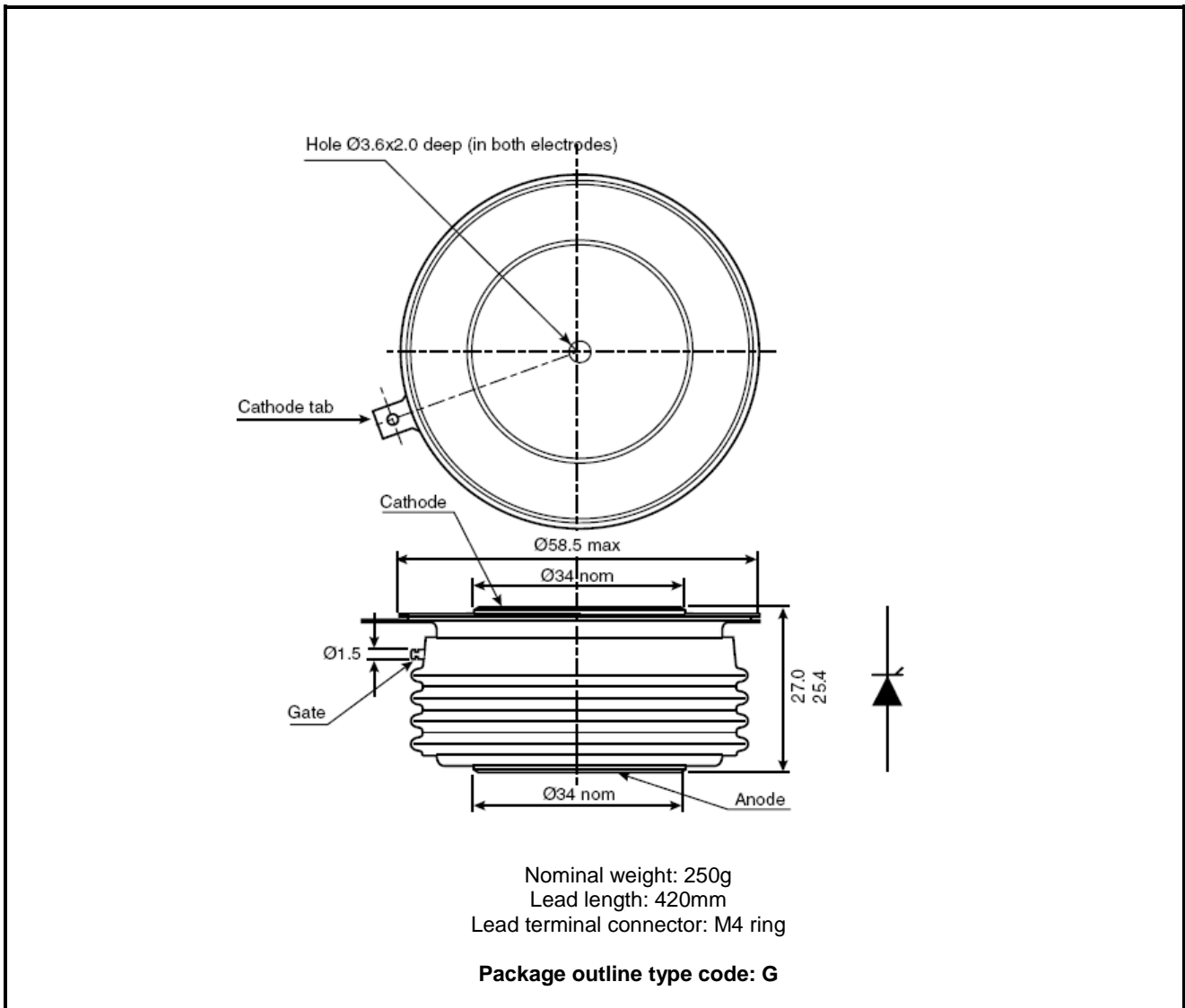

Fig.6 Package outline

POWER ASSEMBLY CAPABILITY

The Power Assembly group was set up to provide a support service for those customers requiring more than the basic semiconductor, and has developed a flexible range of heatsink and clamping systems in line with advances in device voltages and current capability of our semiconductors.

We offer an extensive range of air and liquid cooled assemblies covering the full range of circuit designs in general use today. The Assembly group offers high quality engineering support dedicated to designing new units to satisfy the growing needs of our customers.

Using the latest CAD methods our team of design and applications engineers aim to provide the Power Assembly Complete Solution (PACs).

HEATSINKS

The Power Assembly group has its own proprietary range of extruded aluminium heatsinks which have been designed to optimise the performance of Dynex semiconductors. Data with respect to air natural, forced air and liquid cooling (with flow rates) is available on request.

For further information on device clamps, heatsinks and assemblies, please contact your nearest sales representative or Customer Services.

Stresses above those listed in this data sheet may cause permanent damage to the device. In extreme conditions, as with all semiconductors, this may include potentially hazardous rupture of the package. Appropriate safety precautions should always be followed.



<http://www.dynexsemi.com>

e-mail: power_solutions@dynexsemi.com

**HEADQUARTERS OPERATIONS
DYNEX SEMICONDUCTOR LTD**
Doddington Road, Lincoln
Lincolnshire, LN6 3LF. United Kingdom.
Tel: +44(0)1522 500500
Fax: +44(0)1522 500550

CUSTOMER SERVICE
Tel: +44(0)1522 502753 / 502901. Fax: +44(0)1522 500020

© Dynex Semiconductor 2003 TECHNICAL DOCUMENTATION – NOT FOR
RESALE. PRODUCED IN UNITED KINGDOM.

This publication is issued to provide information only which (unless agreed by the Company in writing) may not be used, applied or reproduced for any purpose nor form part of any order or contract nor to be regarded as a representation relating to the products or services concerned. No warranty or guarantee express or implied is made regarding the capability, performance or suitability of any product or service. The Company reserves the right to alter without prior notice the specification, design or price of any product or service. Information concerning possible methods of use is provided as a guide only and does not constitute any guarantee that such methods of use will be satisfactory in a specific piece of equipment. It is the user's responsibility to fully determine the performance and suitability of any equipment using such information and to ensure that any publication or data used is up to date and has not been superseded. These products are not suitable for use in any medical products whose failure to perform may result in significant injury or death to the user. All products and materials are sold and services provided subject to the Company's conditions of sale, which are available on request.

All brand names and product names used in this publication are trademarks, registered trademarks or trade names of their respective owners.