

APPLICATIONS

- Snubber Diode For GTO Circuits

KEY PARAMETERS

| | |
|-------------|-----------------------------|
| V_{RRM} | 6000V |
| $I_{F(AV)}$ | 400A |
| I_{FSM} | 4200A |
| Q_r | 700μC |
| t_{rr} | 6.0μs |

FEATURES

- Double Side Cooling
- High Surge Capability
- Low Recovery Charge

VOLTAGE RATINGS

| Type Number | Repetitive Peak Reverse Voltage V_{RRM} V | Conditions |
|--------------|---|----------------------------|
| DSF11060SG60 | 6000 | $V_{RSM} = V_{RRM} + 100V$ |
| DSF11060SG58 | 5800 | |
| DSF11060SG56 | 5600 | |
| DSF11060SG55 | 5500 | |

Lower voltage grades available.

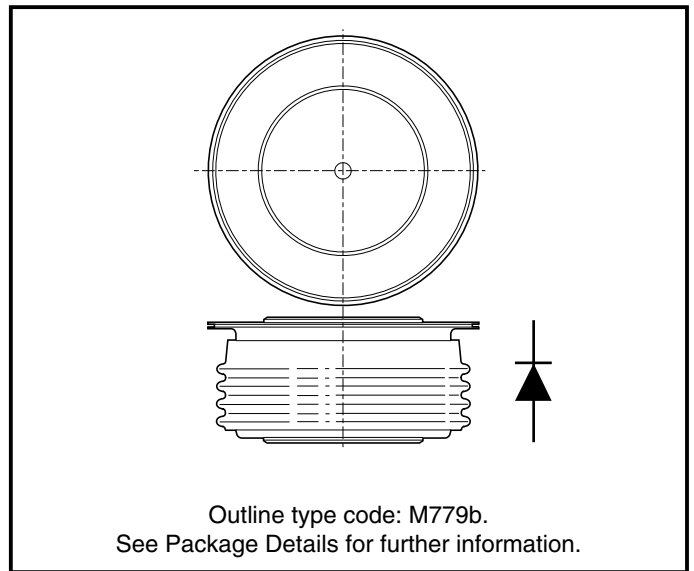

Fig. 1 Package outline

ORDERING INFORMATION

When ordering, select the required part number shown in the Voltage Ratings selection table, e.g.:

DSF11060SG58

Note: Please use the complete part number when ordering and quote this number in any future correspondence relating to your order.

CURRENT RATINGS

| Symbol | Parameter | Conditions | Max. | Units |
|--|-------------------------------------|--|------|-------|
| Double Side Cooled | | | | |
| $I_{F(AV)}$ | Mean forward current | Half wave resistive load, $T_{case} = 65^{\circ}C$ | 400 | A |
| $I_{F(RMS)}$ | RMS value | $T_{case} = 65^{\circ}C$ | 631 | A |
| I_F | Continuous (direct) forward current | $T_{case} = 65^{\circ}C$ | 585 | A |
| Single Side Cooled (Anode side) | | | | |
| $I_{F(AV)}$ | Mean forward current | Half wave resistive load, $T_{case} = 65^{\circ}C$ | 265 | A |
| $I_{F(RMS)}$ | RMS value | $T_{case} = 65^{\circ}C$ | 420 | A |
| I_F | Continuous (direct) forward current | $T_{case} = 65^{\circ}C$ | 365 | A |

SURGE RATINGS

| Symbol | Parameter | Conditions | Max. | Units |
|-----------|--|---|--------------------|--------|
| I_{FSM} | Surge (non-repetitive) forward current | 10ms half sine; with 0% V_{RRM} , $T_j = 150^{\circ}C$ | 4.2 | kA |
| I^2t | I^2t for fusing | | 88×10^3 | A^2s |
| I_{FSM} | Surge (non-repetitive) forward current | 10ms half sine; with 50% V_{RRM} , $T_j = 150^{\circ}C$ | 3.4 | kA |
| I^2t | I^2t for fusing | | 57.8×10^3 | A^2s |

THERMAL AND MECHANICAL DATA

| Symbol | Parameter | Conditions | Min. | Max. | Units | |
|---------------|---------------------------------------|--|-------------|------|-------------|---------------|
| $R_{th(j-c)}$ | Thermal resistance - junction to case | Double side cooled | dc | - | 0.032 | $^{\circ}C/W$ |
| | | Single side cooled | Anode dc | - | 0.064 | $^{\circ}C/W$ |
| | | | Cathode dc | - | 0.064 | $^{\circ}C/W$ |
| $R_{th(c-h)}$ | Thermal resistance - case to heatsink | Clamping force 12kN with mounting compound | Double side | - | 0.008 | $^{\circ}C/W$ |
| | | | Single side | - | 0.016 | $^{\circ}C/W$ |
| T_{vj} | Virtual junction temperature | Forward (conducting) | - | 135 | $^{\circ}C$ | |
| T_{stg} | Storage temperature range | | -55 | 125 | $^{\circ}C$ | |
| - | Clamping force | | 10.8 | 13.2 | kN | |

CHARACTERISTICS

| Symbol | Parameter | Conditions | Typ. | Max. | Units |
|-----------|------------------------------|---|------|------|-----------|
| V_{FM} | Forward voltage | At 600A peak, $T_{case} = 25^{\circ}C$ | - | 3.8 | V |
| I_{RRM} | Peak reverse current | At V_{RRM} , $T_{case} = 125^{\circ}C$ | - | 70 | mA |
| t_{rr} | Reverse recovery time | $I_F = 1000A$, $di_{RR}/dt = 100A/\mu s$ $T_{case} = 125^{\circ}C$, $V_R = 100V$ | 6.0 | - | μs |
| Q_{RA1} | Recovered charge (50% chord) | | - | 1000 | μC |
| I_{RM} | Reverse recovery current | | 350 | - | A |
| K | Soft factor | | 1.7 | - | - |
| V_{TO} | Threshold voltage | At $T_{vj} = 125^{\circ}C$ | - | 1.5 | V |
| r_T | Slope resistance | At $T_{vj} = 125^{\circ}C$ | - | 2.9 | $m\Omega$ |
| V_{FRM} | Forward recovery voltage | $di/dt = 1000A/\mu s$, $T_j = 100^{\circ}C$ | - | 400 | V |

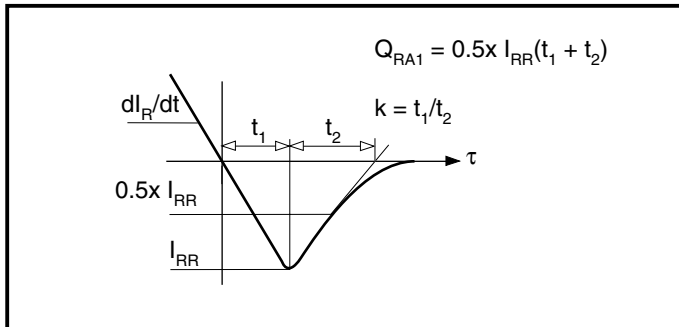
DEFINITION OF K FACTOR AND Q_{RA1}

CURVES

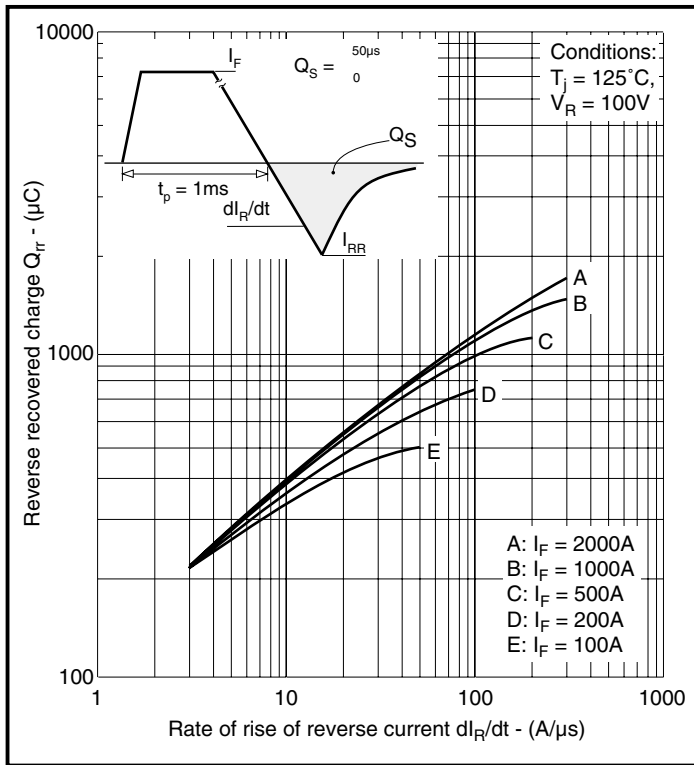

Fig.2 Recovered charge

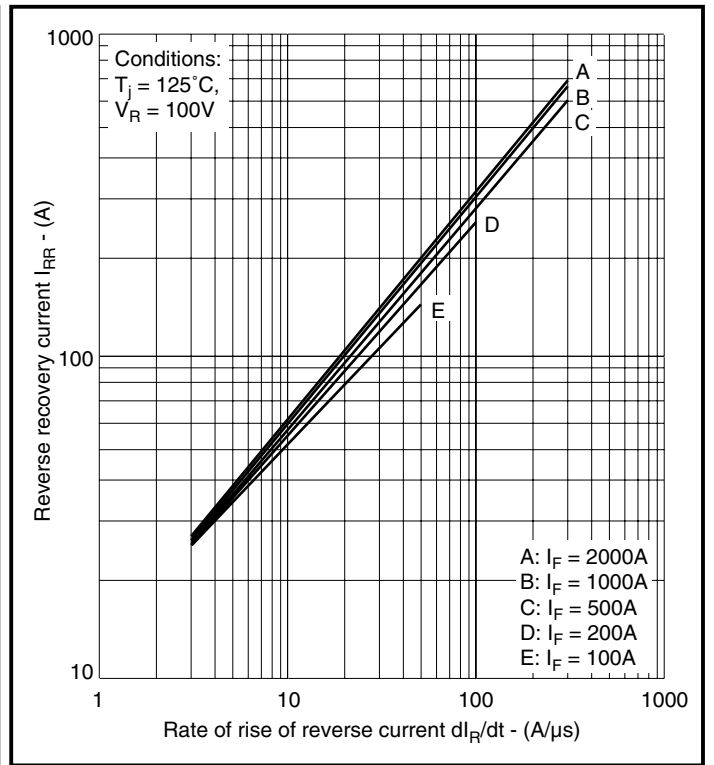

Fig.3 Typical reverse recovery current vs rate of rise of forward current

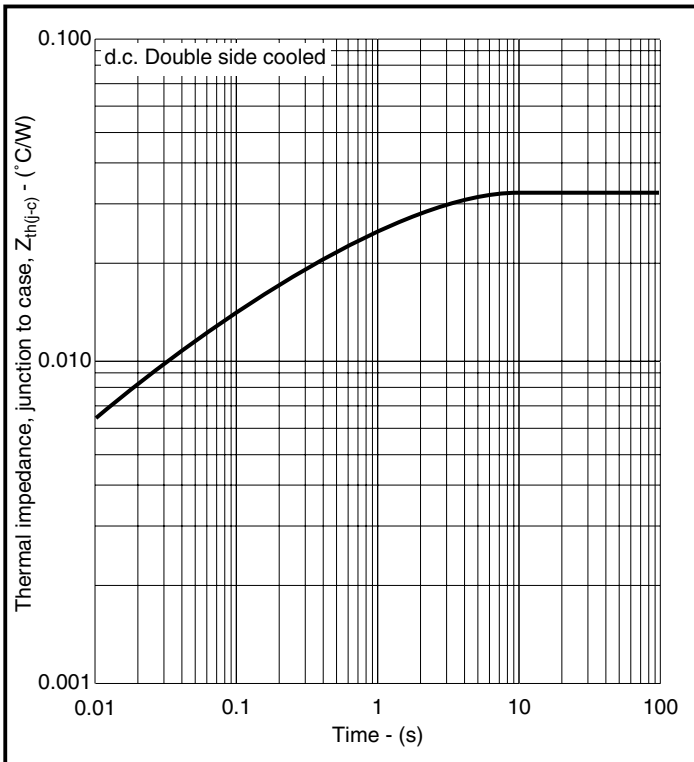

Fig.4 Maximum (limit) transient thermal impedance - junction to case - (°C/W)

PACKAGE DETAILS

(Alternative outline G includes gate connections, all other details are the same as M779b).

For further package information, please contact Customer Services. All dimensions in mm, unless stated otherwise.

DO NOT SCALE.

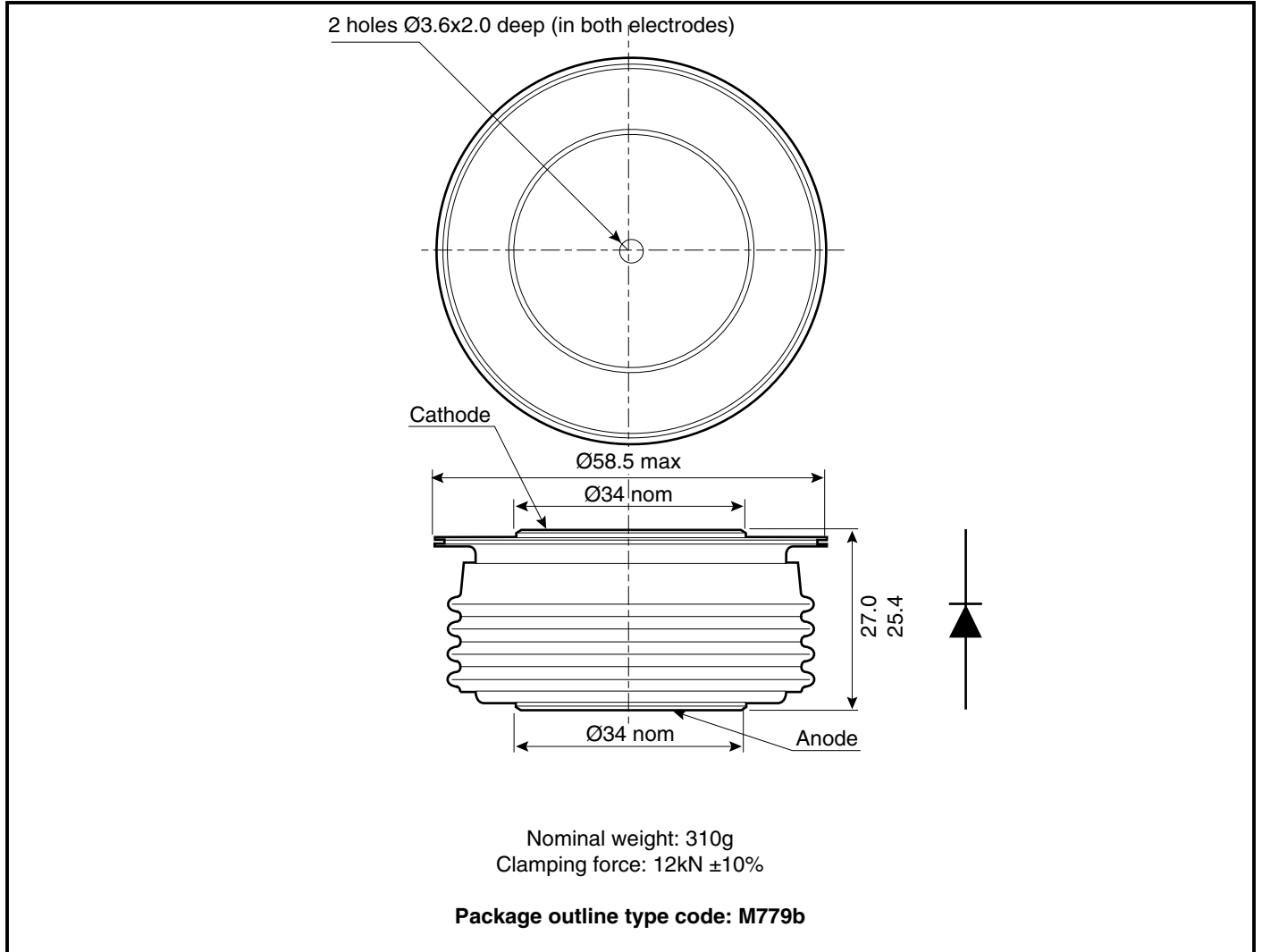

POWER ASSEMBLY CAPABILITY

The Power Assembly group was set up to provide a support service for those customers requiring more than the basic semiconductor, and has developed a flexible range of heatsink and clamping systems in line with advances in device voltages and current capability of our semiconductors.

We offer an extensive range of air and liquid cooled assemblies covering the full range of circuit designs in general use today. The Assembly group offers high quality engineering support dedicated to designing new units to satisfy the growing needs of our customers.

Using the latest CAD methods our team of design and applications engineers aim to provide the Power Assembly Complete Solution (PACs).

HEATSINKS

The Power Assembly group has its own proprietary range of extruded aluminium heatsinks which have been designed to optimise the performance of Dynex semiconductors. Data with respect to air natural, forced air and liquid cooling (with flow rates) is available on request.

For further information on device clamps, heatsinks and assemblies, please contact your nearest sales representative or Customer Services.

Stresses above those listed in this data sheet may cause permanent damage to the device. In extreme conditions, as with all semiconductors, this may include potentially hazardous rupture of the package. Appropriate safety precautions should always be followed.



<http://www.dynexsemi.com>

e-mail: power_solutions@dynexsemi.com

HEADQUARTERS OPERATIONS
DYNEX SEMICONDUCTOR LTD
Doddington Road, Lincoln.
Lincolnshire. LN6 3LF. United Kingdom.
Tel: +44-(0)1522-500500
Fax: +44-(0)1522-500550

CUSTOMER SERVICE
Tel: +44 (0)1522 502753 / 502901. Fax: +44 (0)1522 500020

© Dynex Semiconductor 2003 TECHNICAL DOCUMENTATION – NOT FOR RESALE. PRODUCED IN UNITED KINGDOM

This publication is issued to provide information only which (unless agreed by the Company in writing) may not be used, applied or reproduced for any purpose nor form part of any order or contract nor to be regarded as a representation relating to the products or services concerned. No warranty or guarantee express or implied is made regarding the capability, performance or suitability of any product or service. The Company reserves the right to alter without prior notice the specification, design or price of any product or service. Information concerning possible methods of use is provided as a guide only and does not constitute any guarantee that such methods of use will be satisfactory in a specific piece of equipment. It is the user's responsibility to fully determine the performance and suitability of any equipment using such information and to ensure that any publication or data used is up to date and has not been superseded. These products are not suitable for use in any medical products whose failure to perform may result in significant injury or death to the user. All products and materials are sold and services provided subject to the Company's conditions of sale, which are available on request.

All brand names and product names used in this publication are trademarks, registered trademarks or trade names of their respective owners.