

AK632512W / AK632512Z

524,288 x 32 Bit CMOS / BiCMOS

Static Random Access Memory

DESCRIPTION

The Accutek AK632512 SRAM Module consists of fast high performance SRAMs mounted on a low height, 72 pin SIM or ZIP Board. The module utilizes four 36 pin 512K x 8 SRAMs in 400 mil SOJ packages and four decoupling capacitors mounted on the front side of a printed circuit board.

The SRAMs used have common I/O functions and single output enable functions. Also, four separate chip select (CE) connections are used to independently enable the four bytes. The modules can be supplied in a variety of access time values from 15 nSEC to 35 nSEC in CMOS or BiCMOS technology.

The Accutek module is designed to have a maximum seated height of 0.640 inch SIM or 0.555 inch ZIP to provide for the lowest height off the board. Each conforms to JEDEC-standard sizes and pin-out configurations. Using four pins for module memory density identification, PD₀, PD₁, PD₂ and PD₃ minimizes interchangeability and design considerations when changing from one module size to the other in customer applications.

FEATURES

- 524,288 x 32 bit organization
- JEDEC Standard 72 pin SIM or ZIP format
- Common I/O, single \overline{OE} and \overline{WE} functions with four separate chip selects (CE)
- Fast access times from 15 nSEC
- Low height, 0.640 inch SIM or 0.555 inch ZIP maximum
- Power:
 - 720mA Max Active (20 nSEC)
 - 760mA Max Active (15 nSEC)
 - 800mA Max Active (12 nSEC)
 - 200mA Max Standby

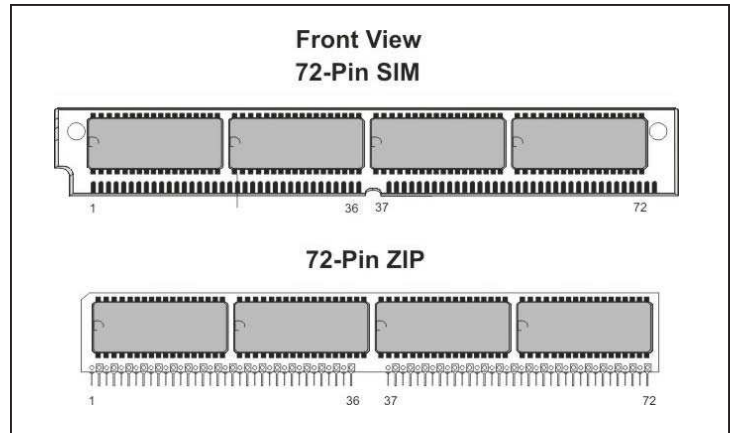

- TTL-compatible inputs and outputs
- Presence Detect, PD₀, PD₁, PD₂ and PD₃ for identifying module density
- Downward compatible with 256K x 32 (AK632256), 128K x 32 (AK632128), 64K x 32 (AK63264) and 32K x 32 (AK63232), 64 pin SIM or ZIP designs
- Upward compatible with 1 Meg x 32 (AK6321024)
- Single 5 volt power supply - AK632512W, AK632512Z
- Single 3.3 volt power supply - AK632512W/3.3, AK632512Z/3.3
- Operating free air temperature 0° to 70°C

ELECTRICAL SPECIFICATIONS

Timing diagrams and basic electrical characteristics are those of the standard 512K x 8 SRAMs used to construct these modules. Accutek's module design allows the flexibility of selecting industry-compatible 512K x 8 SRAMs from several SRAM manufacturers.

PIN NOMENCLATURE

A ₀ - A ₁₈	Address Inputs
\overline{CE}_1 - \overline{CE}_4	Chip Enable
DQ ₁ - DQ ₃₂	Data In/Data Out
\overline{OE}	Output Enable
PD ₀ - PD ₃	Presence Detect
V _{cc}	5v Supply
V _{ss}	Ground
\overline{WE}	Write Enable

MODULE OPTIONS

Leadless SIM: AK632512W
Leaded SIP: AK632512G
Leaded ZIP: AK632512Z

PIN ASSIGNMENT

PIN #	SYMBOL	PIN #	SYMBOL	PIN #	SYMBOL	PIN #	SYMBOL
1	NC	19	A1	37	\overline{CE}_4	55	A5
2	NC	20	A8	38	\overline{CE}_3	56	A12
3	PD ₂	21	A2	39	A17	57	V _{cc}
4	PD ₃	22	A9	40	A16	58	A13
5	V _{ss}	23	DQ13	41	\overline{OE}	59	A6
6	PD ₀	24	DQ5	42	V _{ss}	60	DQ21
7	PD ₁	25	DQ14	43	DQ25	61	DQ29
8	DQ1	26	DQ6	44	DQ17	62	DQ22
9	DQ9	27	DQ15	45	DQ26	63	DQ30
10	DQ2	28	DQ7	46	DQ18	64	DQ23
11	DQ10	29	DQ16	47	DQ27	65	DQ31
12	DQ3	30	DQ8	48	DQ19	66	DQ24
13	DQ11	31	V _{ss}	49	DQ27	67	DQ32
14	DQ4	32	\overline{WE}	50	DQ20	68	V _{ss}
15	DQ12	33	A15	51	A3	69	A18
16	V _{cc}	34	A14	52	A10	70	NC
17	A0	35	\overline{CE}_2	53	A4	71	NC
18	A7	36	\overline{CE}_1	54	A11	72	NC

PD₀ = Open PD₂ = V_{ss}
 PD₁ = Open PD₃ = Open

FUNCTIONAL DIAGRAM

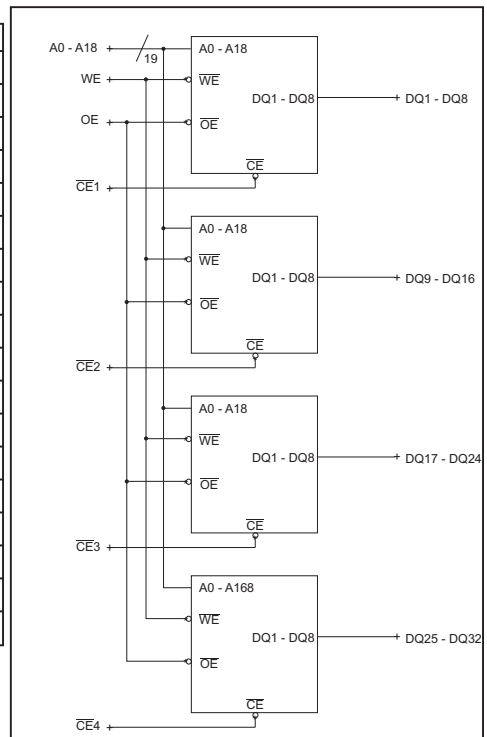

ORDERING INFORMATION

PART NUMBER CODING INTERPRETATION

Position	1	2	3	4	5	6	7	8
1 Product								
	AK = Accuthek Memory							
2 Type								
	4 = Dynamic RAM 5 = CMOS Dynamic RAM 6 = Static RAM							
3 Organization/Word Width								
	1 = by 1 16 = by 16 4 = by 4 32 = by 32 8 = by 8 36 = by 36 9 = by 9							
4 Size/Bits Depth								
	64 = 64K 4096 = 4 MEG 256 = 256K 8192 = 8 MEG 1024 = 1 MEG 16384 = 16 MEG							
5 Package Type								
	G = Single In-Line Package (SIP) S = Single In-Line Module (SIM) D = Dual In-Line Package (DIP) W = .050 inch Pitch Edge Connect Z = Zig-Zag In-Line Package (ZIP)							
6 Special Designation								
	P = Page Mode N = Nibble Mode K = Static Column Mode W = Write Per Bit Mode V = Video Ram							
7 Separator								
	- = Commercial 0°C to +70°C M = Military Equivalent Screened (-55°C to +125°C) I = Industrial Temperature Tested (-45°C to +85°C) X = Burned In							
8 Speed (first two significant digits)								
	DRAMS SRAMS 50 = 50 nS 8 = 8 nS 60 = 60 nS 10 = 10 nS 70 = 70 nS 12 = 25 nS 80 = 80 nS 15 = 15 nS							

The numbers and coding on this page do not include all variations available but are shown as examples of the most widely used variations. Contact Accuthek if other information is required.

EXAMPLES:

AK632512W-15

512K x 32, 15 nSEC SRAM Module, SIM Configuration

AK632512Z-20

512K x 32, 20 nSEC SRAM Module, ZIP Configuration



5 NEW PASTURE ROAD
NEWBURYPORT, MA 01950-4040
PHONE: 978-465-6200 FAX: 978-462-3396
Email: sales@accutekmicro.com
Internet: www.accutekmicro.com

MECHANICAL DIMENSIONS

Inches

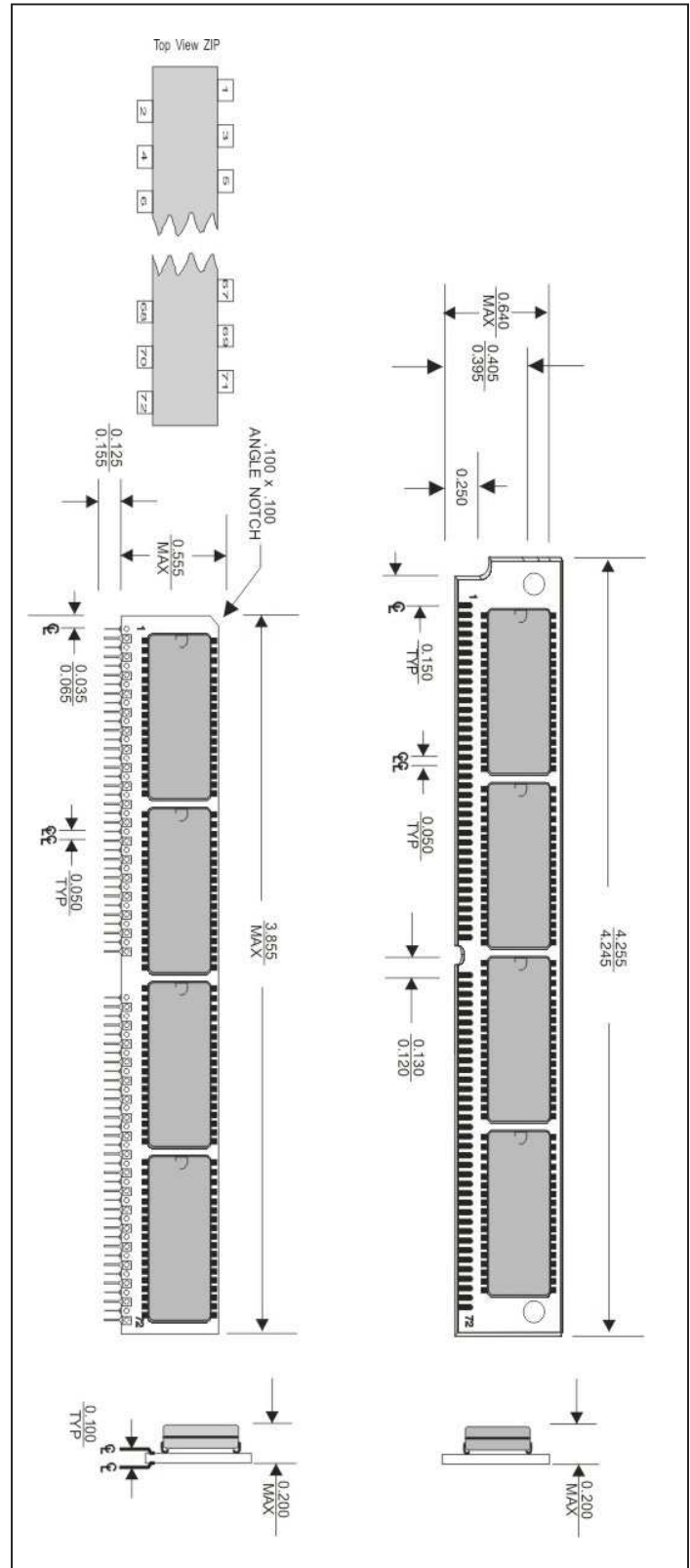

Accuthek reserves the right to make changes in specifications at any time and without notice. Accuthek does not assume any responsibility for the use of any circuitry described; no circuit patent licenses are implied. Preliminary data sheets contain minimum and maximum limits based upon design objectives, which are subject to change upon full characterization over the specific operating conditions.