

AK632256W / AK632256Z 262,144 x 32 Bit CMOS/BiCMOS Static Random Access Memory

DESCRIPTION

The Accutek AK632256 SRAM Module consists of eight fast high performance SRAMs mounted on a low profile, 64 pin SIM or ZIP Board. The module utilizes four 28 pin 256K x 4 SRAMs in SOJ packages and four decoupling capacitors mounted on each side of a printed circuit board.

The SRAMs used have common I/O functions and single output enable functions. Also, four separate chip select (\overline{CE}) connections are used to independently enable the four bytes. The modules can be supplied in a variety of access time values from 12 nSEC to 45 nSEC in CMOS or BiCMOS technology.

The Accutek module is designed to have a maximum seated height of 0.680 inch SIM or 0.540 inch ZIP to provide for the lowest height off the board. By offset-mounting the back surface SRAMs on the SIM version, the module can be mounted in either angled or straight-up SIM sockets. Each conforms to JEDEC standard sizes and pin-out configurations. Using two pins for module memory density identification, PD₀ and PD₁, minimizes interchangeability and design considerations when changing from one module size to another in customer applications.

FEATURES

- 262,144 x 32 bit organization
- JEDEC Standardized 64 pin SIM or ZIP format
- Common I/O, single \overline{OE} functions with four separate chip selects (\overline{CE})
- Low height, 0.680 inch SIM or 0.540 inch ZIP maximum
- Upward compatible with 512K x 32 (AK532512) and 1 Meg x 32 (AK6321024)

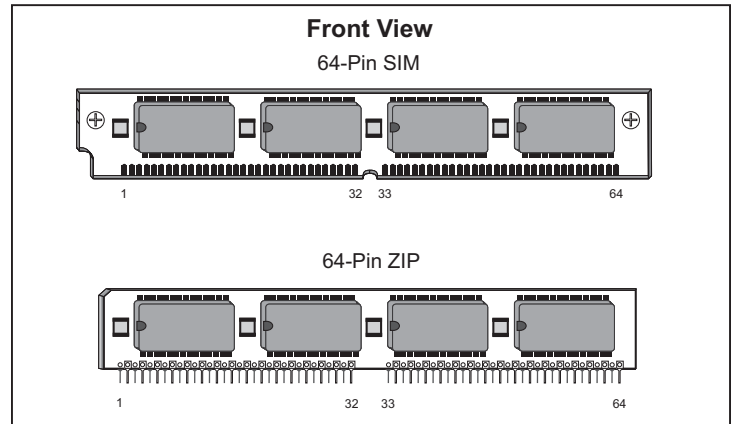

- Downward compatible with 32K x 32 (AK63232), 64K x 32 (AK63264) and 128K x 32 (AK632128)
- Presence Detect PD₀ and PD₁ for identifying module density
- Fast access times range from 12 nSEC BiCMOS to 45 nSEC CMOS
- TTL-compatible inputs and outputs
- Single 5 volt power supply - AK632256W, AK632256Z
- Single 3.3 volt power supply - AK632256W/3.3, AK632256Z/3.3
- Operating temperature range in free air, 0°C to 70°C

ELECTRICAL SPECIFICATIONS

Timing diagrams and basic electrical characteristics are those of the standard 256K x 4 SRAMs used to construct these modules. Accutek's module design allows the flexibility of selecting industry-compatible 256K x 4 SRAMs from several semiconductor manufacturers.

PIN NOMENCLATURE

A ₀ - A ₁₇	Address Inputs
\overline{CE}_1 - \overline{CE}_4	Chip Enable
DQ ₁ - DQ ₃₂	Data In/Data Out
\overline{OE}	Output Enable
PD ₀ - PD ₁	Presence Detect
V _{cc}	Power Supply
V _{ss}	Ground
\overline{WE}	Write Enable

PIN ASSIGNMENT

PIN #	SYMBOL	PIN #	SYMBOL	PIN #	SYMBOL	PIN #	SYMBOL
1	V _{ss}	17	A ₂	33	\overline{CE}_4	49	A ₄
2	PD ₀	18	A ₉	34	\overline{CE}_3	50	A ₁₁
3	PD ₁	19	DQ ₁₃	35	A ₁₇	51	A ₅
4	DQ ₁	20	DQ ₅	36	A ₁₆	52	A ₁₂
5	DQ ₉	21	DQ ₁₄	37	\overline{OE}	53	V _{cc}
6	DQ ₂	22	DQ ₆	38	V _{ss}	54	A ₁₃
7	DQ ₁₀	23	DQ ₁₅	39	DQ ₂₅	55	A ₆
8	DQ ₃	24	DQ ₇	40	DQ ₁₇	56	DQ ₂₁
9	DQ ₁₁	25	DQ ₁₆	41	DQ ₂₆	57	DQ ₂₉
10	DQ ₄	26	DQ ₈	42	DQ ₁₈	58	DQ ₂₂
11	DQ ₁₂	27	V _{ss}	43	DQ ₂₇	59	DQ ₃₀
12	V _{cc}	28	\overline{WE}	44	DQ ₁₉	60	DQ ₂₃
13	A ₀	29	A ₁₅	45	DQ ₂₈	61	DQ ₃₁
14	A ₇	30	A ₁₄	46	DQ ₂₀	62	DQ ₂₄
15	A ₁	31	\overline{CE}_2	47	A ₃	63	DQ ₃₂
16	A ₈	32	\overline{CE}_1	48	A ₁₀	64	V _{ss}

PD₀ = V_{ss}
PD₁ = V_{ss}

FUNCTIONAL DIAGRAM

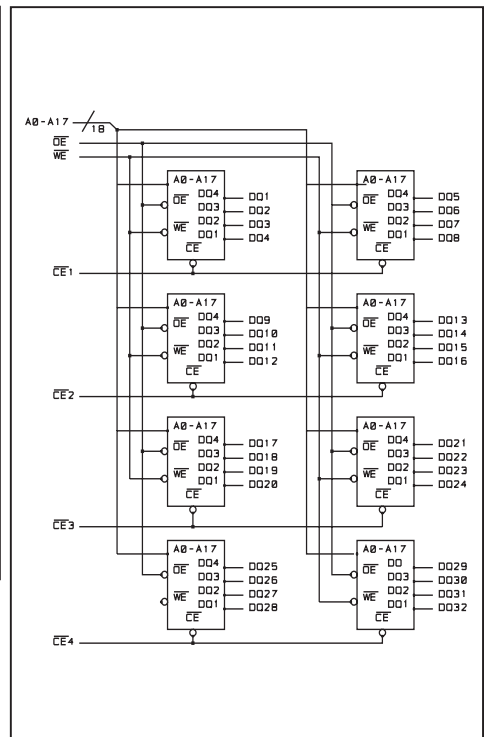

MODULE OPTIONS

Leadless SIM: AK632256W
Leaded SIP: AK632256G
Leaded ZIP: AK632256Z

ORDERING INFORMATION

PART NUMBER CODING INTERPRETATION

Position 1 2 3 4 5 6 7 8

1 Product

AK = Accuthek Memory

2 Type

4 = Dynamic RAM
5 = CMOS Dynamic RAM
6 = Static RAM

3 Organization/Word Width

1 = by 1 16 = by 16
4 = by 4 32 = by 32
8 = by 8 36 = by 36
9 = by 9

4 Size/Bits Depth

64 = 64K 4096 = 4 MEG
256 = 256K 8192 = 8 MEG
1024 = 1 MEG 16384 = 16 MEG

5 Package Type

G = Single In-Line Package (SIP)
S = Single In-Line Module (SIM)
D = Dual In-Line Package (DIP)
W = .050 inch Pitch Edge Connect
Z = Zig-Zag In-Line Package (ZIP)

6 Special Designation

P = Page Mode
N = Nibble Mode
K = Static Column Mode
W = Write Per Bit Mode
V = Video Ram

7 Separator

- = Commercial 0°C to +70°C
M = Military Equivalent Screened (-55°C to +125°C)
I = Industrial Temperature Tested (-45°C to +85°C)
X = Burned In

8 Speed (first two significant digits)

DRAMS		SRAMS	
60 = 60 nS	12 = 12 nS		
70 = 70 nS	20 = 20 nS		
80 = 80 nS	25 = 25 nS		
10 = 100 nS	35 = 35 nS		

The numbers and coding on this page do not include all variations available but are shown as examples of the most widely used variations. Contact Accuthek if other information is required.

EXAMPLES:

AK632256W-12

256K x 32, 12 nSEC SRAM Module, SIM Configuration

AK632256Z-15

256K x 32, 15 nSEC SRAM Module, ZIP Configuration



5 NEW PASTURE ROAD
NEWBURYPORT, MA 01950-4040
PHONE: 978-465-6200 FAX: 978-462-3396
Email: sales@accutekmicro.com
Internet: www.accutekmicro.com

MECHANICAL DIMENSIONS

Inches

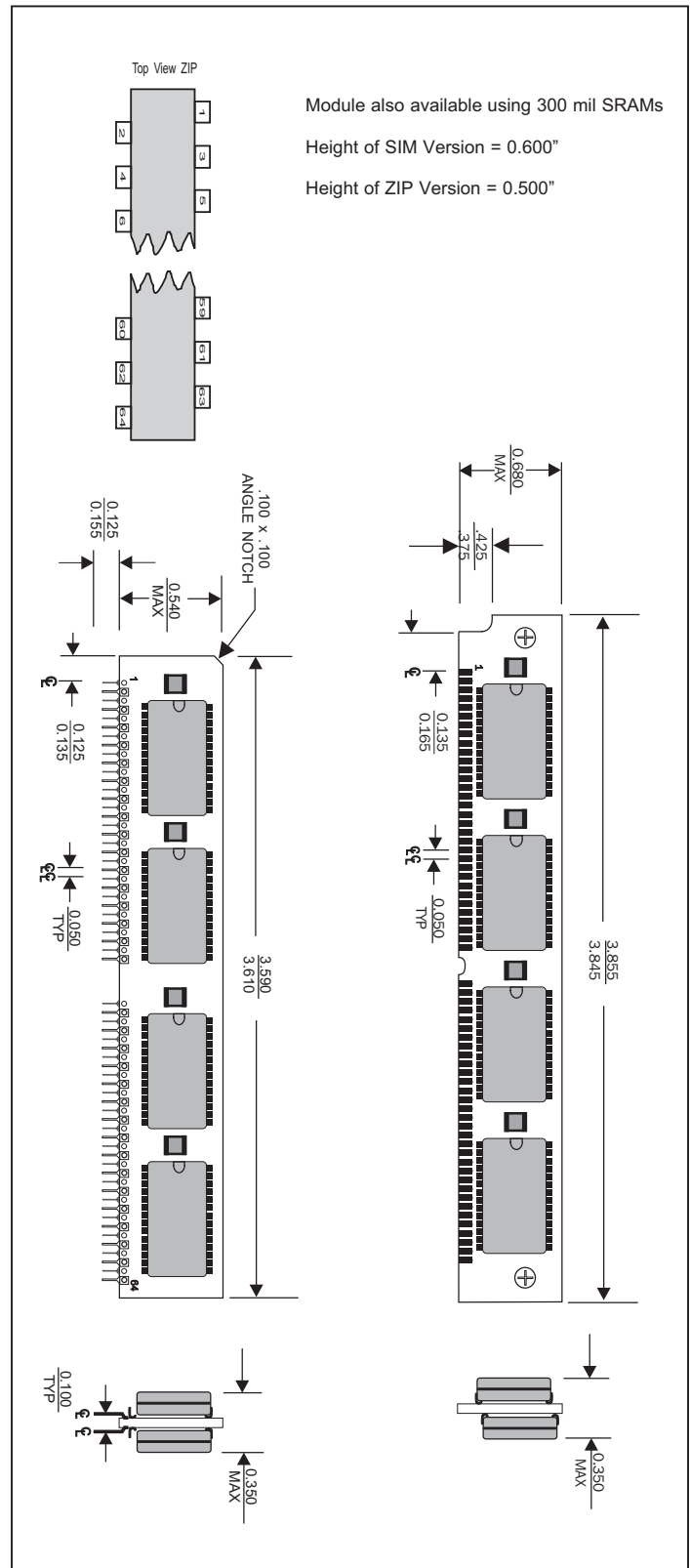

Accuthek reserves the right to make changes in specifications at any time and without notice. Accuthek does not assume any responsibility for the use of any circuitry described; no circuit patent licenses are implied. Preliminary data sheets contain minimum and maximum limits based upon design objectives, which are subject to change upon full characterization over the specific operating conditions.