

DESCRIPTION

The Accutek AK632256W-72 SRAM Module consists of fast high performance SRAMs mounted on a low profile, 72 pin SIM Board. The module utilizes four 28 pin 256K x 4 SRAMs in 400 mil SOJ packages and four decoupling capacitors mounted on each side of a printed circuit board.

The SRAMs used have common I/O functions and single output enable functions. Also, four separate chip select (\overline{CE}) connections are used to independently enable the four bytes. The modules can be supplied in a variety of access time values from 12 nSEC to 45 nSEC in CMOS or BiCMOS technology.

The Accutek module is designed to have a maximum seated height of 0.680 inch to provide for the lowest height off the board. By off-set-mounting the back surface SRAMs the module can be mounted in either angled or straight-up SIM sockets. The module conforms to JEDEC standard sizes and pin-out configurations. Using four pins for module memory density identification, PD₀ to PD₃, minimizes interchangeability and design considerations when changing from one module size to another in customer applications.

FEATURES

- 262,144 x 32 bit organization
- JEDEC Standardized 72 pin SIM or ZIP pinout
- Common I/O, single \overline{OE} functions with four separate chip selects (\overline{CE})
- Low height, 0.680 inch maximum
- Upward compatible with 512K x 32 (AK632512) and 1 Meg x 32 (AK6321024)

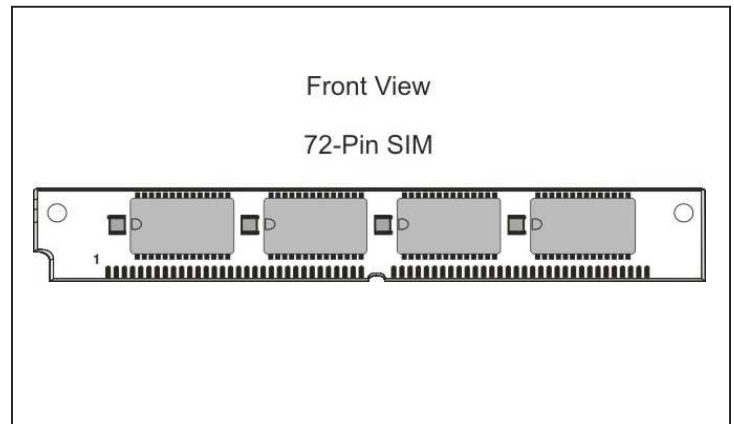

- Downward compatible with 32K x 32 (AK63232), 64K x 32 (AK63264) and 128K x 32 AK632128
- Presence Detect PD₀ to PD₃ for identifying module density
- Fast access times range from 12 nSEC BiCMOS to 45 nSEC CMOS
- TTL-compatible inputs and outputs
- Single 5 volt power supply - AK632256W-72
- Single 3.3 volt power supply - AK632256W-72/3.3
- Operating temperature range in free air, 0°C to 70°C

ELECTRICAL SPECIFICATIONS

Timing diagrams and basic electrical characteristics are those of the standard 256K x 4 SRAMs used to construct these modules. Accutek's module design allows the flexibility of selecting industry-compatible 256K x 4 SRAMs from several semiconductor manufacturers.

PIN NOMENCLATURE

A ₀ - A ₁₇	Address Inputs
\overline{CE}_1 - \overline{CE}_4	Chip Enable
DQ ₁ - DQ ₃₂	Data In/Data Out
\overline{OE}	Output Enable
PD ₀ - PD ₃	Presence Detect
V _{cc}	5v Supply
V _{ss}	Ground
\overline{WE}	Write Enable
NC	No Connect

PIN ASSIGNMENT

PIN #	SYMBOL	PIN #	SYMBOL	PIN #	SYMBOL	PIN #	SYMBOL
1	NC	19	A1	37	\overline{CE}_4	55	A5
2	NC	20	A8	38	\overline{CE}_3	56	A12
3	PD2/NC	21	A2	39	A17	57	V _{cc}
4	PD3/NC	22	A9	40	A16	58	A13
5	V _{ss}	23	DQ13	41	\overline{OE}	59	A6
6	PD0	24	DQ5	42	V _{ss}	60	DQ21
7	PD1	25	DQ14	43	DQ25	61	DQ29
8	DQ1	26	DQ6	44	DQ17	62	DQ22
9	DQ9	27	DQ15	45	DQ26	63	DQ38
10	DQ2	28	DQ7	46	DQ18	64	DQ23
11	DQ10	29	DQ16	47	DQ27	65	DQ31
12	DQ3	30	DQ8	48	DQ19	66	DQ24
13	DQ11	31	V _{ss}	49	DQ28	67	DQ32
14	DQ4	32	\overline{WE}	50	DQ20	68	V _{ss}
15	DQ12	33	A15	51	A3	69	A18/NC
16	V _{cc}	34	A14	52	A10	70	A19/NC
17	A0	35	\overline{CE}_2	53	A4	71	NC
18	A7	36	\overline{CE}_1	54	A11	72	NC

PD₀ = V_{ss} PD₂ = Open
PD₁ = V_{ss} PD₃ = Open

FUNCTIONAL DIAGRAM

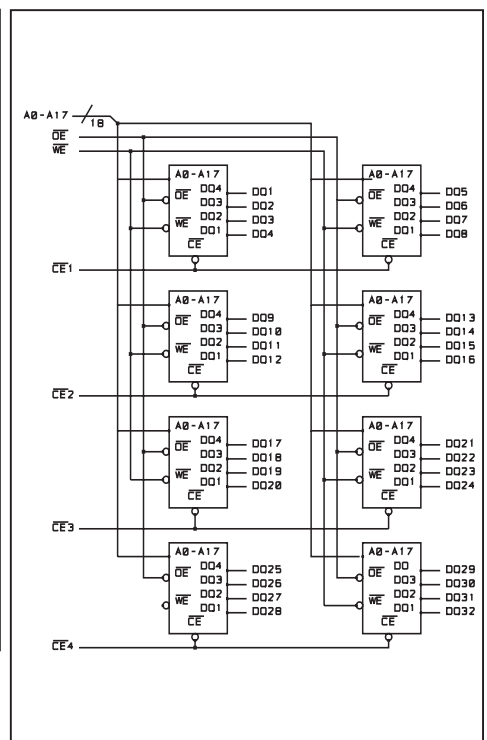

MODULE OPTIONS

Leadless SIM: AK632256W-72

ORDERING INFORMATION

PART NUMBER CODING INTERPRETATION

Position	1	2	3	4	5	6	7	8										
1 Product	AK = Accutek Memory																	
2 Type	4 = Dynamic RAM 5 = CMOS Dynamic RAM 6 = Static RAM																	
3 Organization/Word Width	1 = by 1 16 = by 16 4 = by 4 32 = by 32 8 = by 8 36 = by 36 9 = by 9																	
4 Size/Bits Depth	64 = 64K 4096 = 4 MEG 256 = 256K 8192 = 8 MEG 1024 = 1 MEG 16384 = 16 MEG																	
5 Package Type	G = Single In-Line Package (SIP) S = Single In-Line Module (SIM) D = Dual In-Line Package (DIP) W = .050 inch Pitch Edge Connect Z = Zig-Zag In-Line Package (ZIP)																	
6 Special Designation	P = Page Mode N = Nibble Mode K = Static Column Mode W = Write Per Bit Mode V = Video Ram																	
7 Separator	- = Commercial 0°C to +70°C M = Military Equivalent Screened (-55°C to +125°C) I = Industrial Temperature Tested (-45°C to +85°C) X = Burned In																	
8 Speed (first two significant digits)	<table border="0"> <tr> <td>DRAMS</td> <td>SRAMS</td> </tr> <tr> <td>50 = 50 nS</td> <td>8 = 8 nS</td> </tr> <tr> <td>60 = 60 nS</td> <td>10 = 10 nS</td> </tr> <tr> <td>70 = 70 nS</td> <td>12 = 12 nS</td> </tr> <tr> <td>80 = 80 nS</td> <td>15 = 15 nS</td> </tr> </table>								DRAMS	SRAMS	50 = 50 nS	8 = 8 nS	60 = 60 nS	10 = 10 nS	70 = 70 nS	12 = 12 nS	80 = 80 nS	15 = 15 nS
DRAMS	SRAMS																	
50 = 50 nS	8 = 8 nS																	
60 = 60 nS	10 = 10 nS																	
70 = 70 nS	12 = 12 nS																	
80 = 80 nS	15 = 15 nS																	

The numbers and coding on this page do not include all variations available but are shown as examples of the most widely used variations. Contact Accutek if other information is required.

EXAMPLES:

AK632256W72-12

256K x 32, 12 nSEC SRAM Module, 72 Pin SIM Configuration



5 NEW PASTURE ROAD
NEWBURYPORT, MA 01950-4040
PHONE: 978-465-6200 FAX: 978-462-3396
Email: sales@accutekmicro.com
Internet: www.accutekmicro.com

MECHANICAL DIMENSIONS

Inches

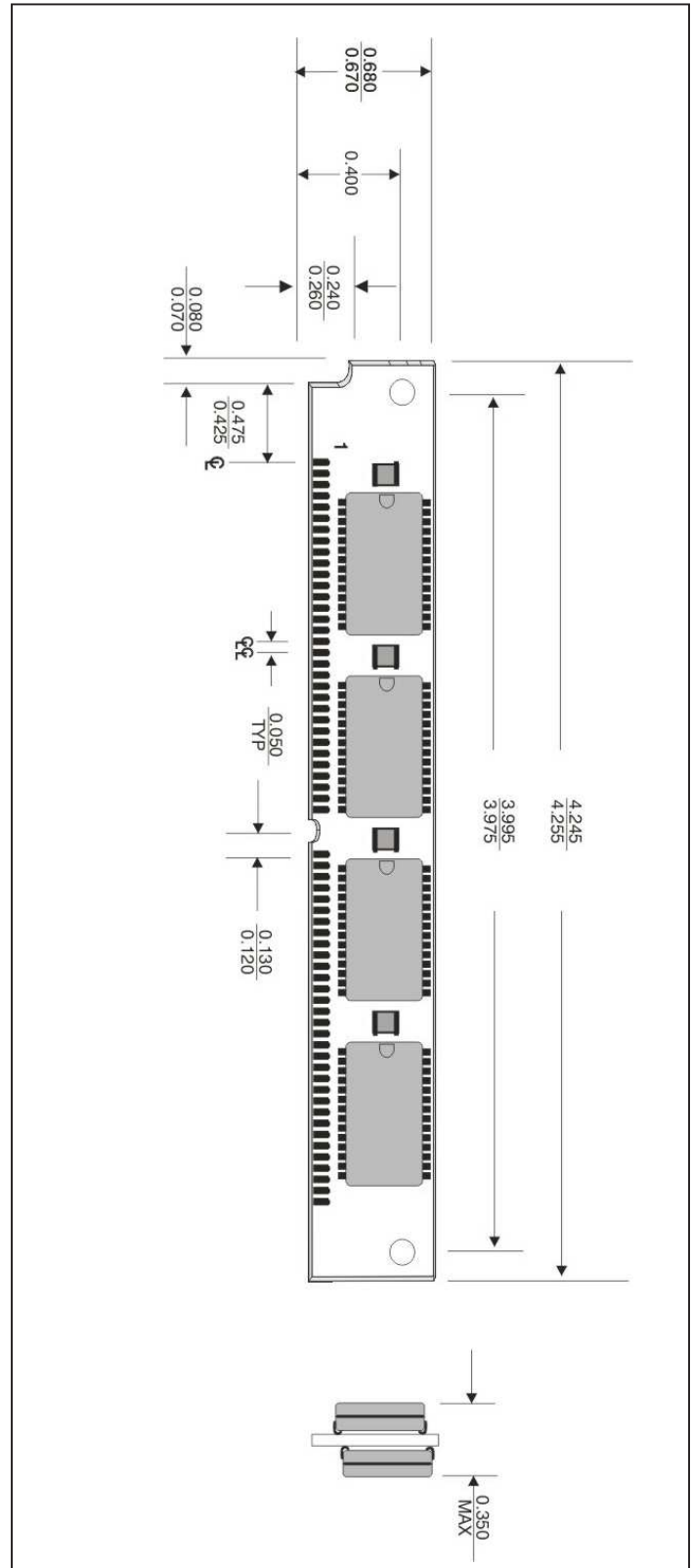

Accutek reserves the right to make changes in specifications at any time and without notice. Accutek does not assume any responsibility for the use of any circuitry described; no circuit patent licenses are implied. Preliminary data sheets contain minimum and maximum limits based upon design objectives, which are subject to change upon full characterization over the specific operating conditions.