

DESCRIPTION

The Accutek AK632128 SRAM Module consists of fast high performance SRAMs mounted on a low height, 64 pin SIM or ZIP PCB. The module utilizes four 32 pin 128K x 8 SRAMs in 400 mil SOJ packages and four decoupling capacitors mounted on the front side of a printed circuit board.

The SRAMs used have common I/O functions and single output enable functions. Also, four separate chip select (\overline{CE}) connections are used to independently enable the four bytes. The modules can be supplied in a variety of access time values from 7nSEC to 35nSEC in CMOS or BiCMOS technology.

The Accutek module is designed to have a maximum seated height of 0.620 inch SIM or 0.540 inch ZIP to provide for the lowest height off the board. Each conforms to JEDEC-standard sizes and pin-out configurations. Using two pins for module density identification, PD₀ and PD₁, minimizes interchangeability and design considerations when changing from one module size to the other in customer applications.

FEATURES

- 131,072 x 32 bit organization
- JEDEC Standard 64 pin SIM or ZIP format
- Access times as fast as 7nSEC
- TTL compatible inputs and outputs
- Very low profile, 0.620 inch MAX seated height SIM Version
- Very low profile, 0.540 inch MAX seated height ZIP Version
- Single 5 Volt power supply - AK632128W, AK632128Z

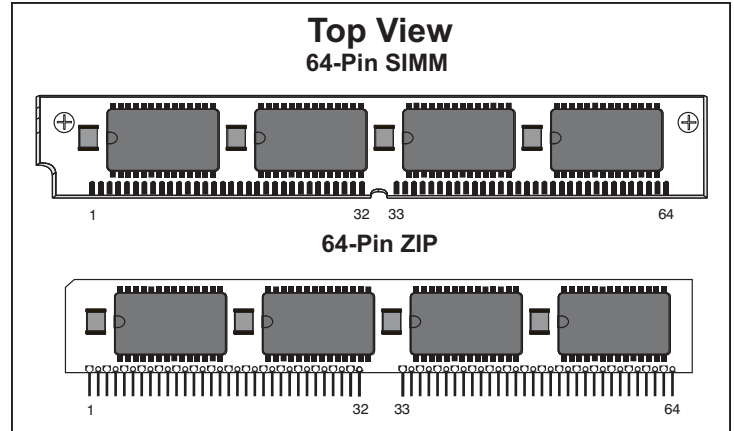

- Single 3.3 Volt power supply - AK63128W/3.3, AK632128Z/3.3
- Common I/O, single \overline{OE} functions with four separate chip selects (\overline{CE})
- Presence Detect PD₀ and PD₁ for identifying module density
- Downward compatible with 32K x 32 (AK63232) and 64K x 32 (AK63264)
- Upward compatible with 256K x 32 (AK632256), 512K x 32 (AK632512) and 1 Meg x 32 (AK6321024)
- Operating free air temperature 0⁰ to 70⁰C

ELECTRICAL SPECIFICATIONS

Timing diagrams and basic electrical characteristics are those of the standard 128K x 8 SRAMs used to construct these modules. Accutek's module design allows the flexibility of selecting industry-compatible 128K x 8 SRAMs from at least seven semiconductor manufacturers.

PIN NOMENCLATURE

A ₀ - A ₁₆	Address Inputs
\overline{CE}_1 - \overline{CE}_4	Chip Enable
DQ ₁ - DQ ₃₂	Data In/Data Out
\overline{OE}	Output Enable
PD ₀ - PD ₁	Presence Detect
V _{cc}	Power Supply
V _{ss}	Ground
\overline{WE}	Write Enable
NC	No Connect

PIN ASSIGNMENT

PIN #	SYMBOL	PIN #	SYMBOL	PIN #	SYMBOL	PIN #	SYMBOL
1	V _{ss}	17	A ₂	33	\overline{CE}_4	49	A ₄
2	PD ₀	18	A ₉	34	\overline{CE}_3	50	A ₁₁
3	PD ₁	19	DQ ₁₃	35	NC	51	A ₅
4	DQ ₁	20	DQ ₅	36	A ₁₆	52	A ₁₂
5	DQ ₉	21	DQ ₁₄	37	\overline{OE}	53	V _{cc}
6	DQ ₂	22	DQ ₆	38	V _{ss}	54	A ₁₃
7	DQ ₁₀	23	DQ ₁₅	39	DQ ₂₅	55	A ₆
8	DQ ₃	24	DQ ₇	40	DQ ₁₇	56	DQ ₂₁
9	DQ ₁₁	25	DQ ₁₆	41	DQ ₂₆	57	DQ ₂₉
10	DQ ₄	26	DQ ₈	42	DQ ₁₈	58	DQ ₂₂
11	DQ ₁₂	27	V _{ss}	43	DQ ₂₇	59	DQ ₃₀
12	V _{cc}	28	\overline{WE}	44	DQ ₁₉	60	DQ ₂₃
13	A ₀	29	A ₁₅	45	DQ ₂₈	61	DQ ₃₁
14	A ₇	30	A ₁₄	46	DQ ₂₀	62	DQ ₂₄
15	A ₁	31	\overline{CE}_2	47	A ₃	63	DQ ₃₂
16	A ₈	32	\overline{CE}_1	48	A ₁₀	64	V _{ss}

PD₀ = Open
PD₁ = Open

FUNCTIONAL DIAGRAM

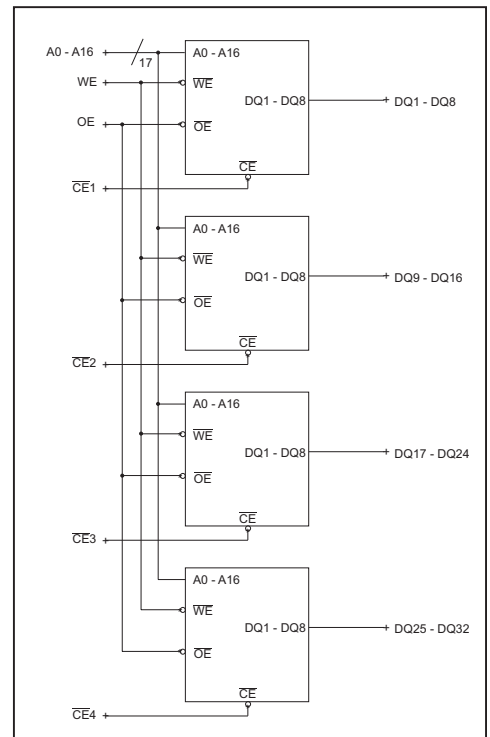

MODULE OPTIONS

Leadless SIM: AK632128W
Leaded ZIP: AK632128Z

ORDERING INFORMATION

PART NUMBER CODING INTERPRETATION

Position 1 2 3 4 5 6 7 8

1 Product

AK = Accuthek Memory

2 Type

4 = Dynamic RAM
5 = CMOS Dynamic RAM
6 = Static RAM

3 Organization/Word Width

1 = by 1 16 = by 16
4 = by 4 32 = by 32
8 = by 8 36 = by 36
9 = by 9

4 Size/Bits Depth

64 = 64K 4096 = 4 MEG
256 = 256K 8192 = 8 MEG
1024 = 1 MEG 16384 = 16 MEG

5 Package Type

G = Single In-Line Package (SIP)
S = Single In-Line Module (SIM)
D = Dual In-Line Package (DIP)
W = .050 inch Pitch Edge Connect
Z = Zig-Zag In-Line Package (ZIP)

6 Special Designation

P = Page Mode
N = Nibble Mode
K = Static Column Mode
W = Write Per Bit Mode
V = Video Ram

7 Separator

- = Commercial 0°C to +70°C
M = Military Equivalent Screened (-55°C to +125°C)
I = Industrial Temperature Tested (-45°C to +85°C)
X = Burned In

8 Speed (first two significant digits)

DRAMS	SRAMS
60 = 60 nS	8 = 8 nS
70 = 70 nS	10 = 10 nS
80 = 80 nS	12 = 12 nS
10 = 100 nS	15 = 15 nS

The numbers and coding on this page do not include all variations available but are shown as examples of the most widely used variations. Contact Accuthek if other information is required.

EXAMPLES

AK632128W-15

128K x 32, 15 nSEC SRAM Module, SIM Configuration

AK632128Z-20

128K x 32, 20 nSEC SRAM Module, ZIP Configuration

MECHANICAL DIMENSIONS

Inches

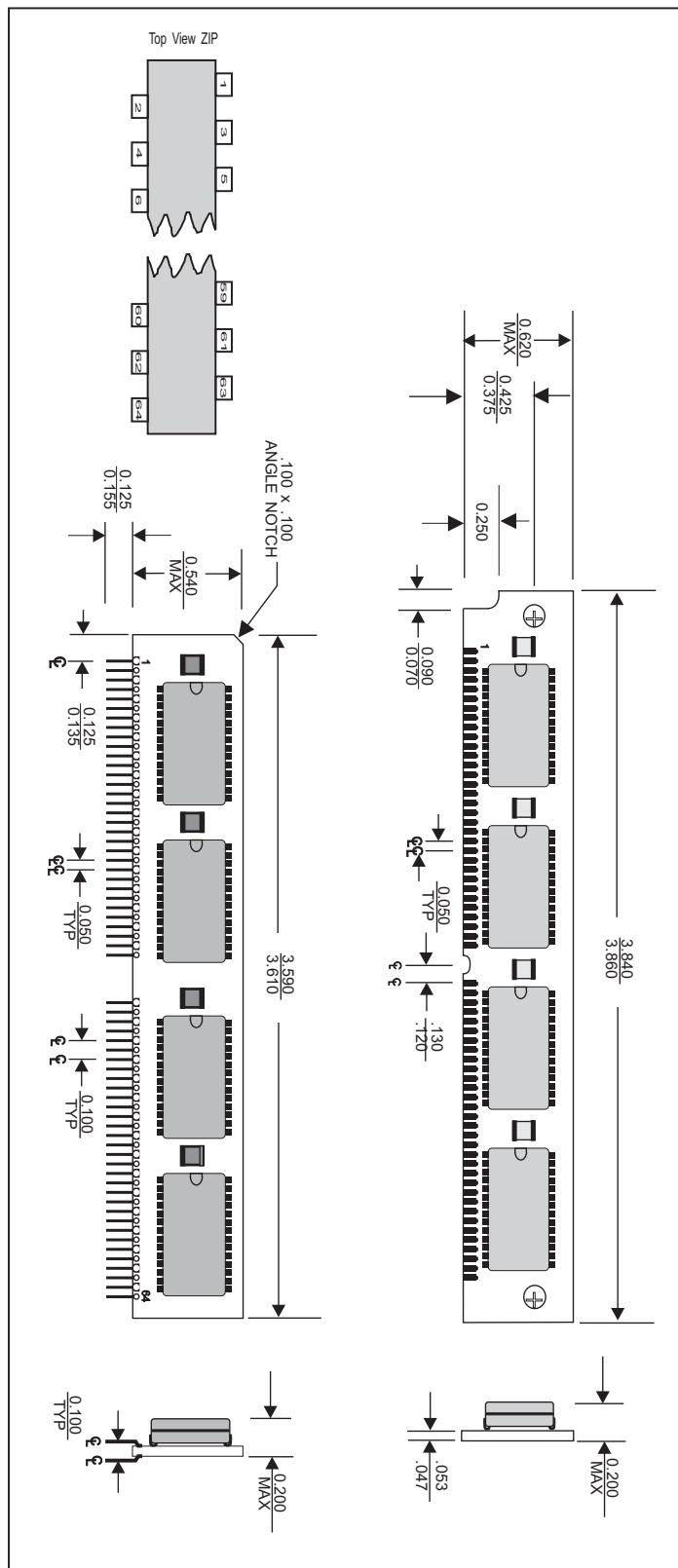

Accuthek reserves the right to make changes in specifications at any time and without notice. Accuthek does not assume any responsibility for the use of any circuitry described; no circuit patent licenses are implied. Preliminary data sheets contain minimum and maximum limits based upon design objectives, which are subject to change upon full characterization over the specific operating conditions.