



This new family of Accutek DIP Adapter Modules converts surface mount IC's to pin compatible DIP packages for creating drop-in replacements for end-of-life DIP IC's. Package types supported are: SOJ, PLCC, SOIC, SOP, TSOP, QSOP, HSOP, MSOP, LLP (Leadless Leadframe Package), CSP (Chip Scale Package) and CLCC.

These DIP Adapters were developed for users with motherboard designs that require DIP's, now obsolete by manufacturers. These adapter modules save costly motherboard redesigns.

Available with machined or flat contact pins. Accutek DIP Adapter Modules feature 4 to 84 pins, are fully assembled and tested and may include a decoupling capacitor. These DIP Adapters can be manufactured turnkey or from customer supplied surface mount chips. Modules range in length from 0.200" to 4.200" depending on number of pins and incorporate 0.300", 0.400", 0.600", 0.900", 1.200" and 1.400" row-to-row spacing with 0.100" lead spacing.

Custom configurations up to 200 pins, multi-chip and double sided modules are also available for special functions. A variety of pin lengths with varying diameters as well as custom sizes and spacing can be specified with different materials and finishes. All modules are designed in-house using PCB CAD workstations. Automated assembly and 100% testing are also performed in-house.

44 Pin DIP Adapters

DIP ADAPTER MODULES ELIMINATE THE NEED TO REDESIGN MOTHERBOARDS OR MAY BE USED FOR BREADBOARD PROTOTYPING

FEATURES

- Saves costly redesign of current motherboards
- Fully tested with lifetime limited warranty
- May include an on board decoupling capacitor
- IC assembly and testing available
- EPROM and Flash programming available
- Custom lead lengths available
- Custom multi-chip and double-sided modules available

ORDERING OPTIONS

- Adapter only
- Customer supplies chips - Accutek assembles on Accutek adapters, tests and delivers finished product in antistatic tubes.
- Complete turnkey - Accutek purchases IC's and passives. Then assembles, tests and delivers finished product in antistatic tubes.

AK44D600-QFP .5mm 7x7
 7x7 QFP .5mm PITCH
 TO 44 PIN DIP

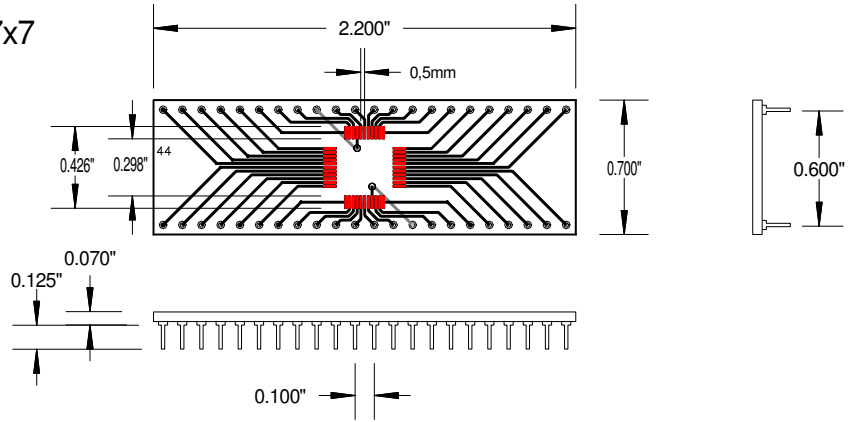

AK44D600-QFP .65mm
 QFP .65mm PITCH
 TO 44 PIN DIP

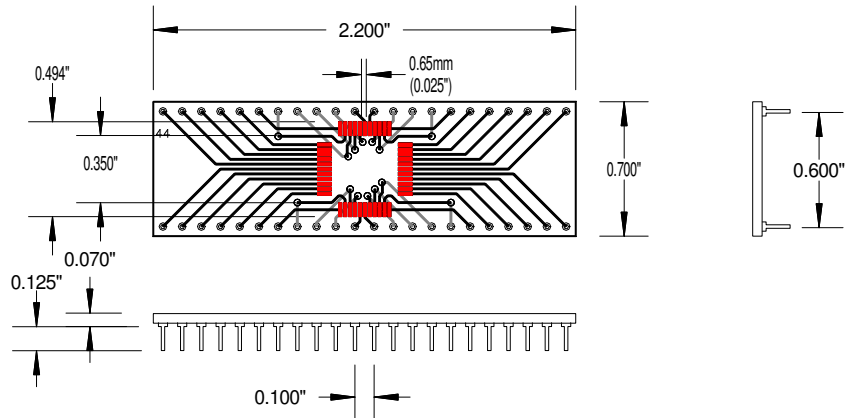

AK44D600-QFP .8mm 10x10
 10x10 QFP .8mm PITCH
 TO 44 PIN DIP

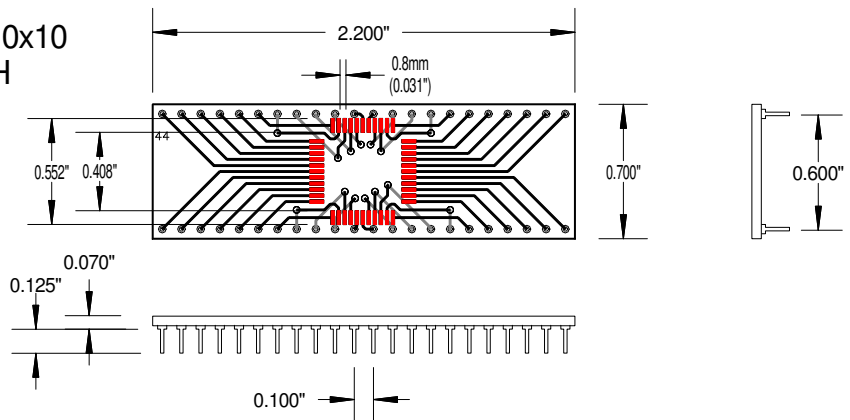

AK44D900-QFP 1.0mm
 QFP 1.0mm PITCH
 TO 44 PIN DIP

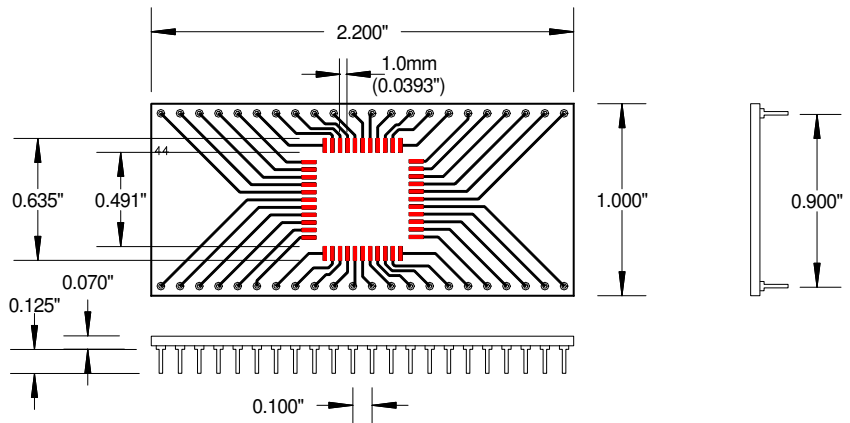

AK44D600-LLP
 LEADLESS LEADFRAME PACKAGE
 (7 X 7mm) (10pin x 12pin)
 TO 44 PIN 0.600" DIP

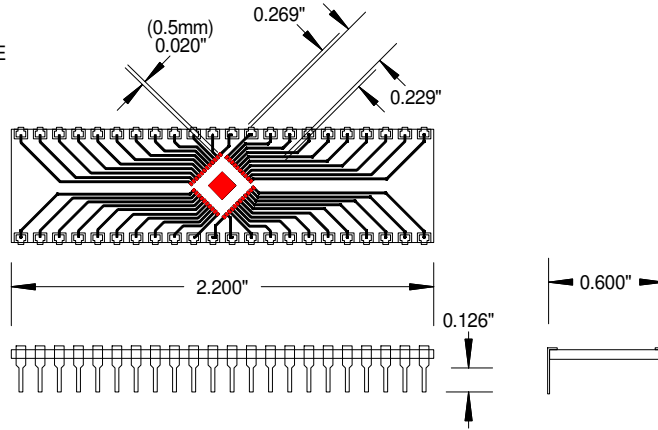

AK44D600-SOJ
 400 MIL SOJ
 TO 44 PIN DIP

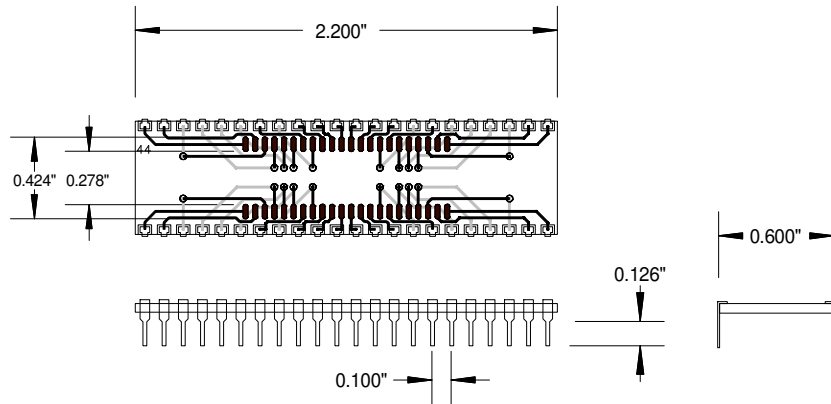

AK44D900-PLCC
 44 PIN PLCC TO DIP

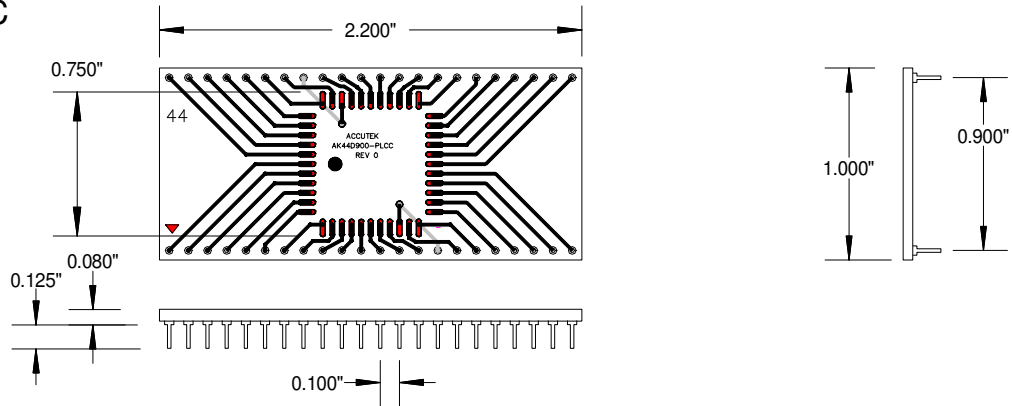

AK44DS900-PLCC
 (with PLCC Socket included)
 44 PIN PLCC SOCKET TO DIP

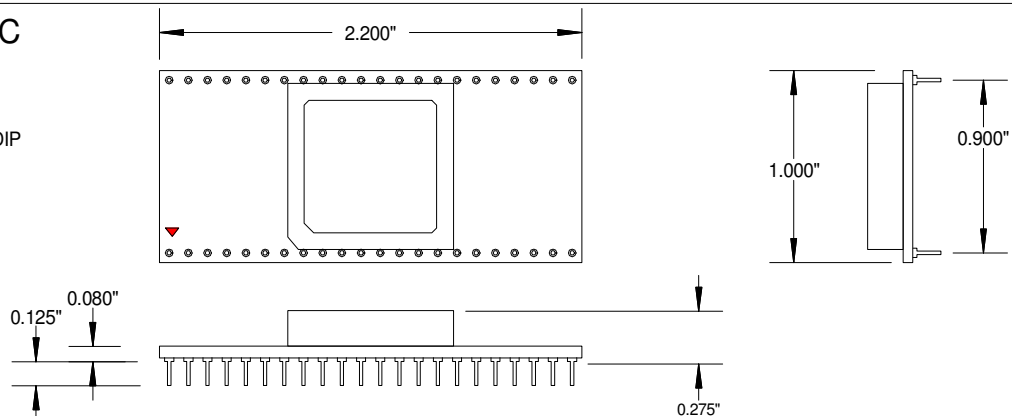

AK44D600-TSSOP.8
 .8MM TSSOP
 TO 44 PIN DIP

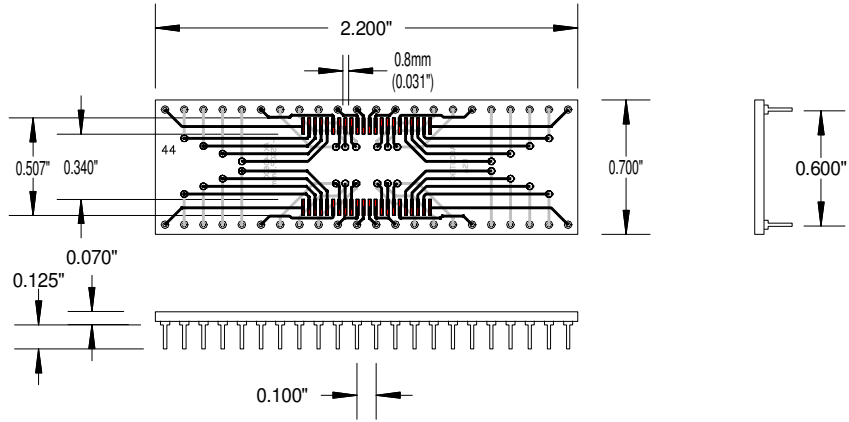

AK44D600-TSSOP.65
 .65MM TSSOP
 TO 44 PIN DIP

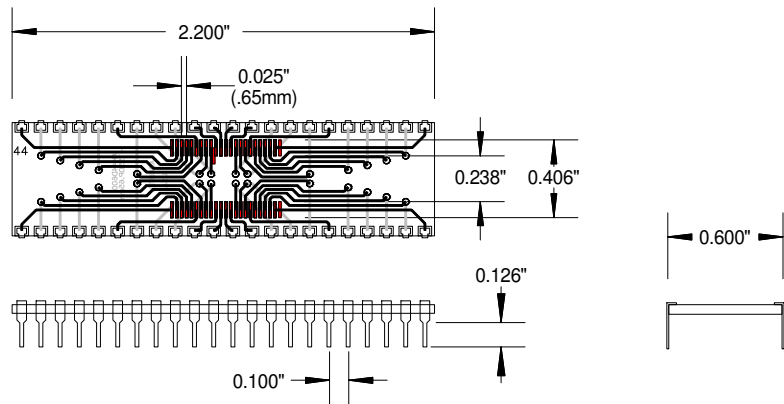

AK44D600-TSSOP.5
 .5MM TSSOP
 TO 44 PIN DIP

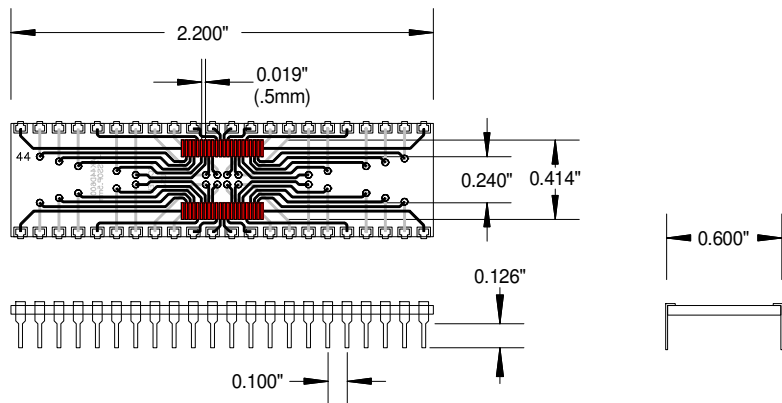

AK44D600-TSSOP.4
 .4MM TSSOP
 TO 44 PIN DIP

