

20 Pin to 24 DIP Adapters

DIP ADAPTER MODULES ELIMINATE THE NEED TO REDESIGN MOTHERBOARDS OR MAY BE USED FOR BREADBOARD PROTOTYPING

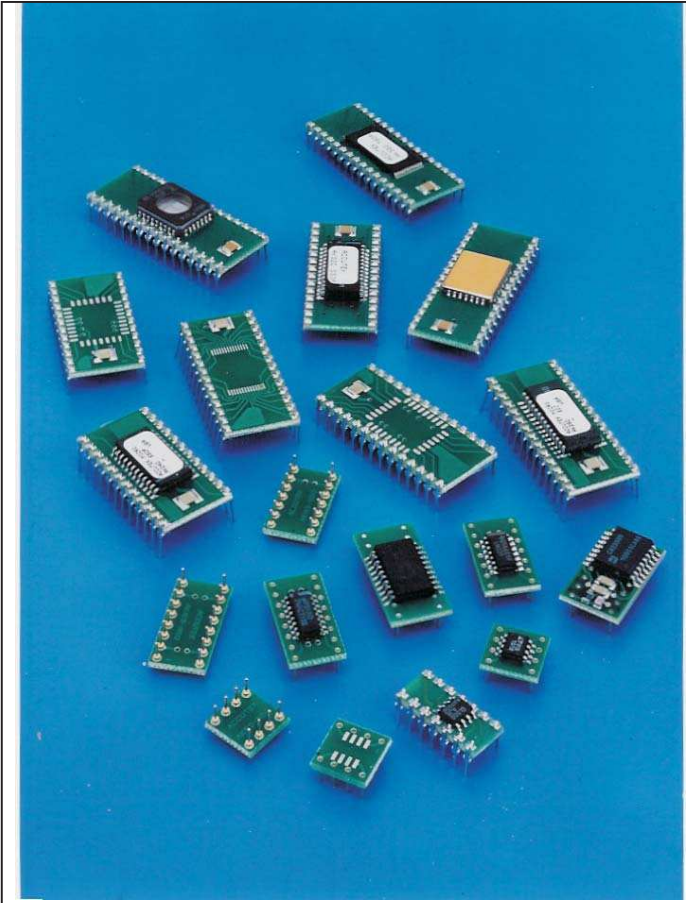

This new family of Accutek DIP Adapter Modules converts surface mount IC's to pin compatible DIP packages for creating drop-in replacements for end-of-life DIP IC's. Package types supported are: SOJ, PLCC, SOIC, SOP, TSOP, QSOP, HSOP, MSOP, LLP (Leadless Leadframe Package), CSP (Chip Scale Package) and CLCC.

These DIP Adapters were developed for users with motherboard designs that require DIP's, now obsolete by manufacturers. These adapter modules save costly motherboard redesigns.

Available with machined or flat contact pins. Accutek DIP Adapter Modules feature 4 to 84 pins, are fully assembled and tested and may include a decoupling capacitor. These DIP Adapters can be manufactured turnkey or from customer supplied surface mount chips. Modules range in length from 0.200" to 4.200" depending on number of pins and incorporate 0.300", 0.400", 0.600", 0.900", 1.200" and 1.400" row-to-row spacing with 0.100" lead spacing.

Custom configurations up to 200 pins, multi-chip and double sided modules are also available for special functions. A variety of pin lengths with varying diameters as well as custom sizes and spacing can be specified with different materials and finishes. All modules are designed in-house using PCB CAD workstations. Automated assembly and 100% testing are also performed in-house.

FEATURES

- Saves costly redesign of current motherboards
- Fully tested with lifetime limited warranty
- May include an on board decoupling capacitor
- IC assembly and testing available
- EPROM and Flash programming available
- Custom lead lengths available
- Custom multi-chip and double-sided modules available

ORDERING OPTIONS

- Adapter only
- Customer supplies chips - Accutek assembles on Accutek adapters, tests and delivers finished product in antistatic tubes.
- Complete turnkey - Accutek purchases IC's and passives. Then assembles, tests and delivers finished product in antistatic tubes.

We can assemble your chips on to our adapter boards. Fully automated assembly and test at our Newburyport, Massachusetts facility.



No job is too large or too small.

AK20D300-NWSO

20 PIN NARROW OR WIDE SOIC TO DIP

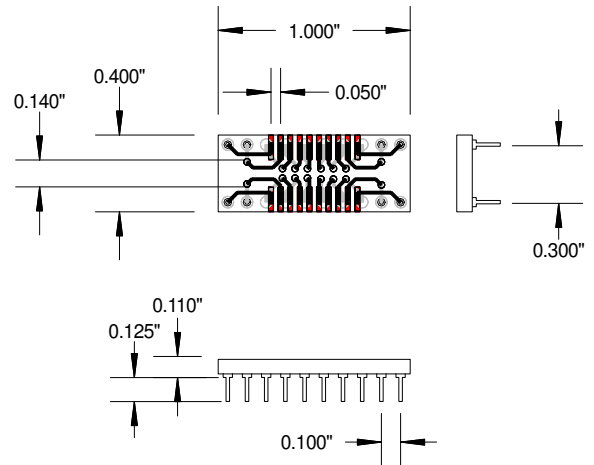

AK20D300-WSO

20 PIN WIDE SOIC TO DIP

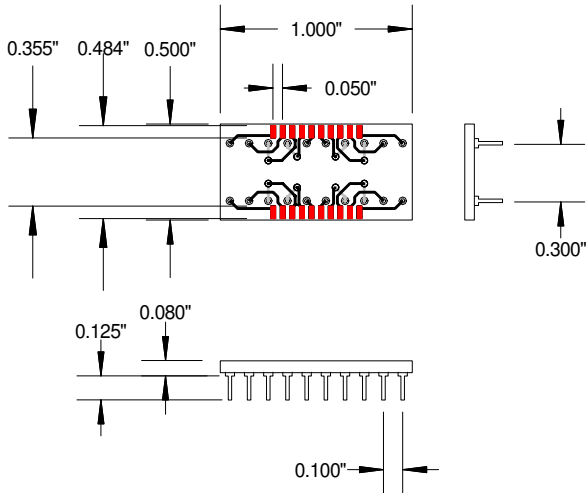

AK20D300-HSOP

20 PIN HSOP TO DIP

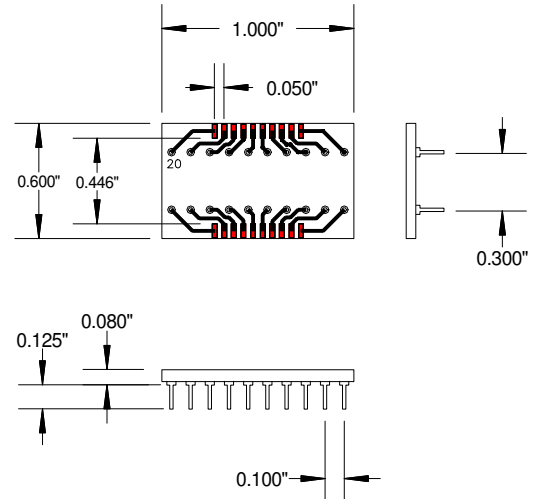

AK20D300-SSOP.8mm

20 PIN SSOP 0.8mm PITCH TO DIP

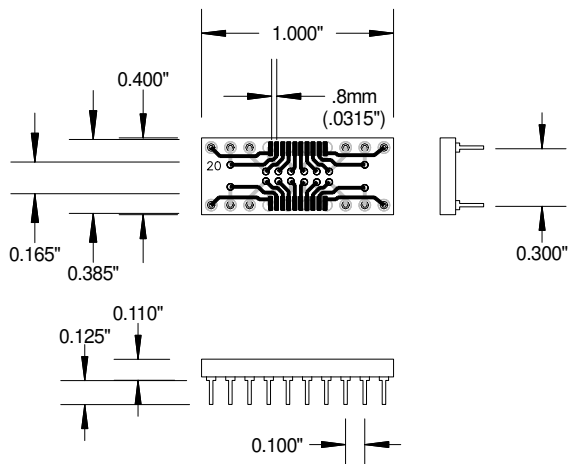

AK20D400-SOIC.89mm

20 PIN .89mm PITCH SOIC TO DIP

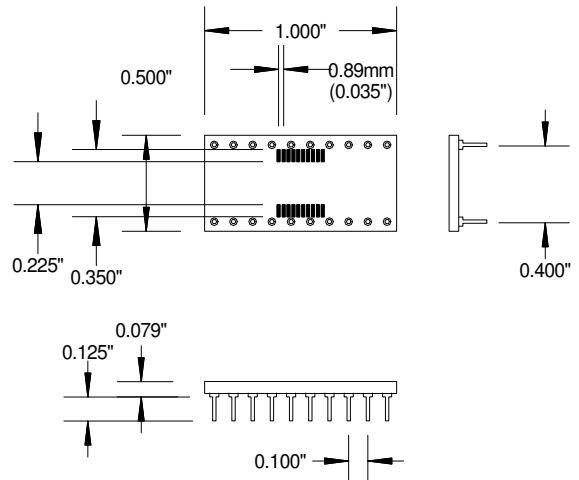

AK20D300-TSOP

20 PIN TSOP & SSOP .65mm PITCH TO DIP

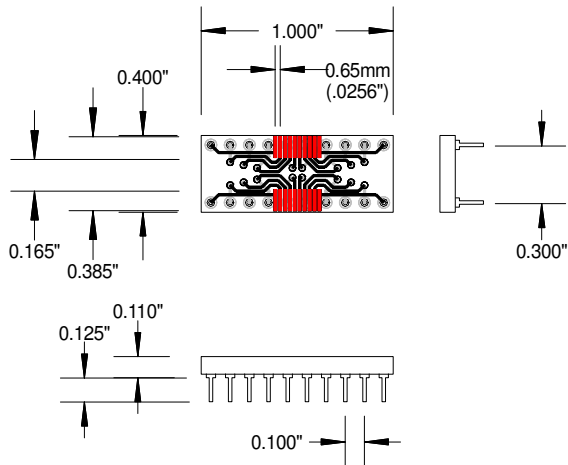

AK20D300-QSOP

20 PIN QSOP 0.025" PITCH TO DIP

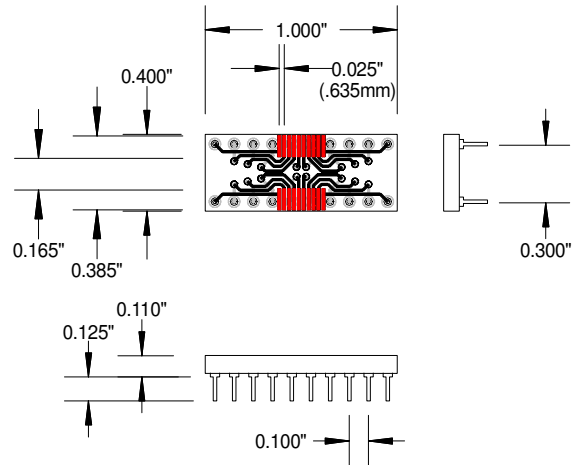

AK20D300-PLCC

20 PIN PLCC TO DIP

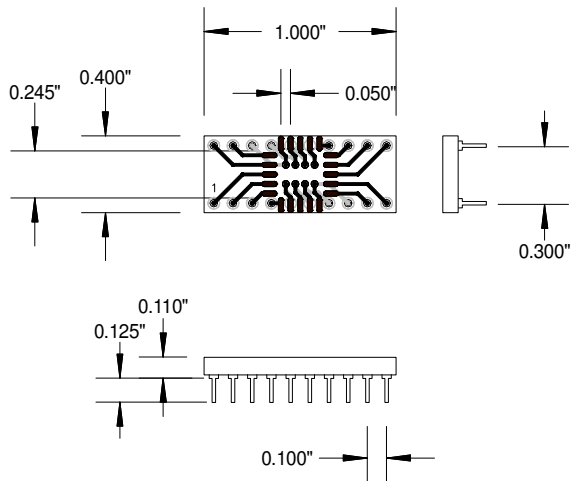

AK20DS300-PLCC

(with PLCC Socket included)

20 PIN PLCC SOCKET TO DIP

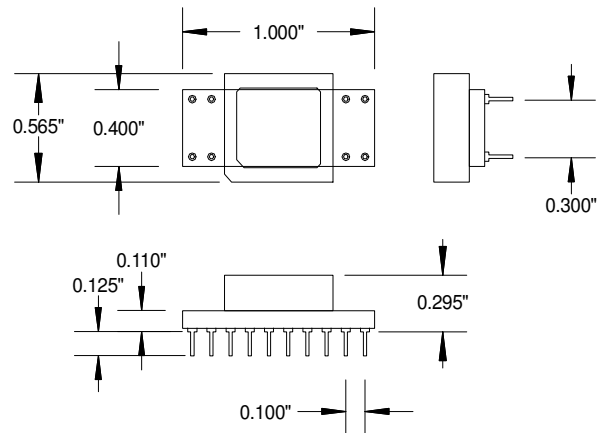

AK20D300-PLCC-A

20 PIN PLCC TO DIP WITH DECOUPLING CAPACITOR

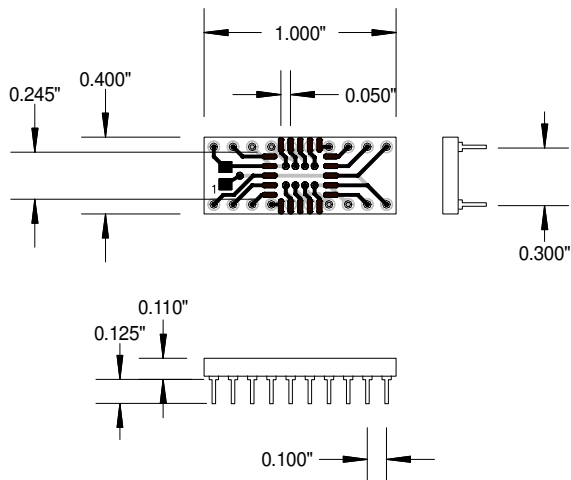

AK20D300-PLCC-R

20 PIN PLCC TO DIP WITH PLCC MIRROR IMAGED

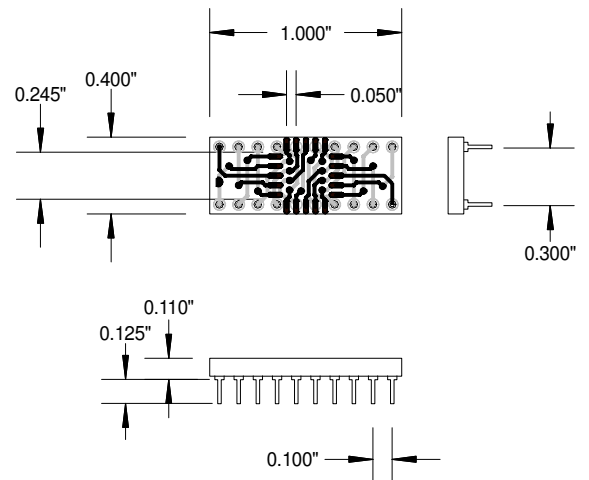

AK20D300-SOJ
(for 1Meg & 4 Meg DRAMs)

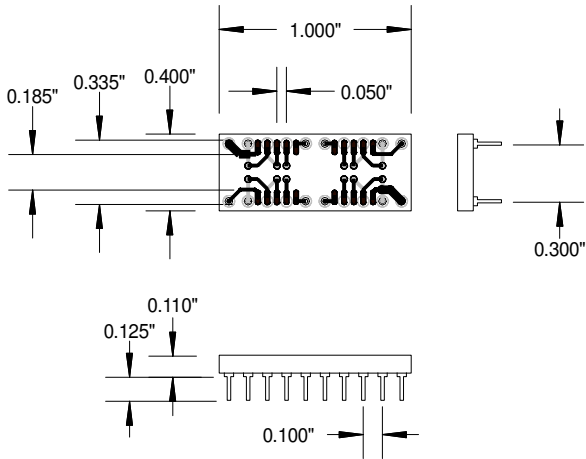

AK22D300-QSOP
22 PIN QSOP & SSOP TO DIP

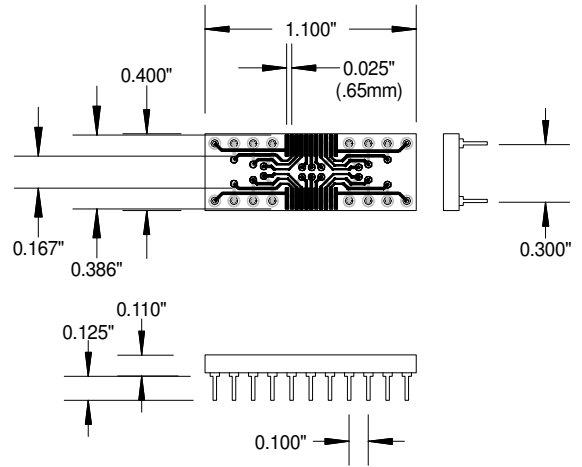

AK22D300-DFN
22 PIN DFN 0.65MM PITCH TO DIP

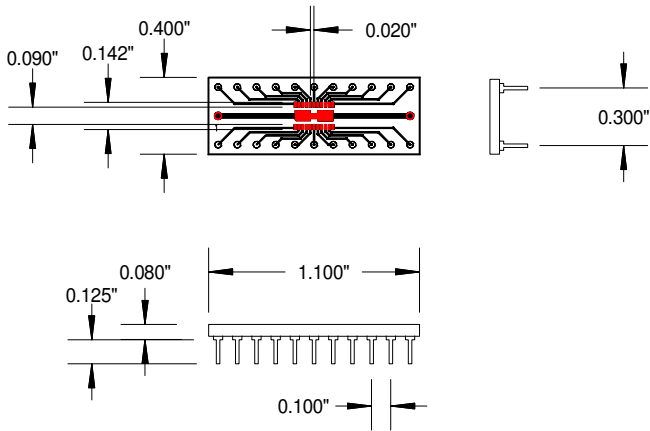

AK24D300-SOIC
24 PIN SOIC TO DIP

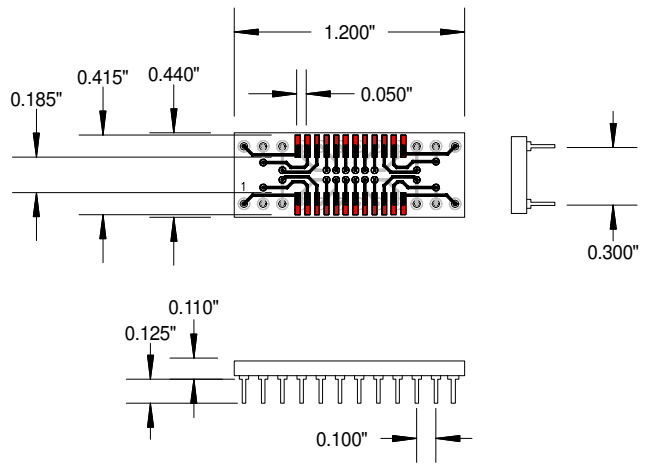

AK24D300-SOJ
24 PIN SOJ TO DIP

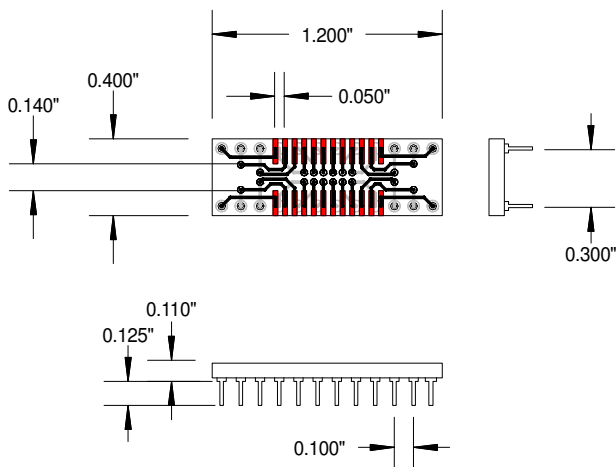

AK24D600-SOIC
24 PIN SOIC TO .600" DIP

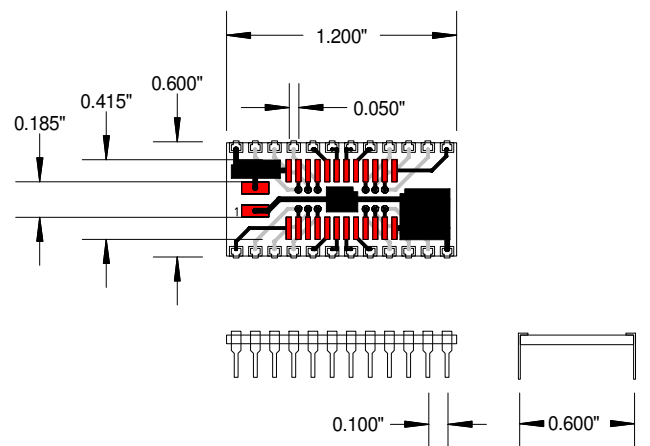

AK24D300-SSOP.8mm
24 PIN SSOP 0.8mm PITCH TO DIP

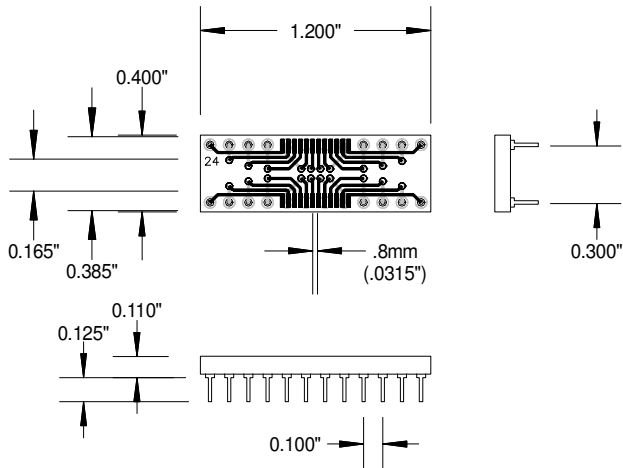

AK24D300-TSOP
24 PIN TSOP & SSOP 0.65mm PITCH TO DIP

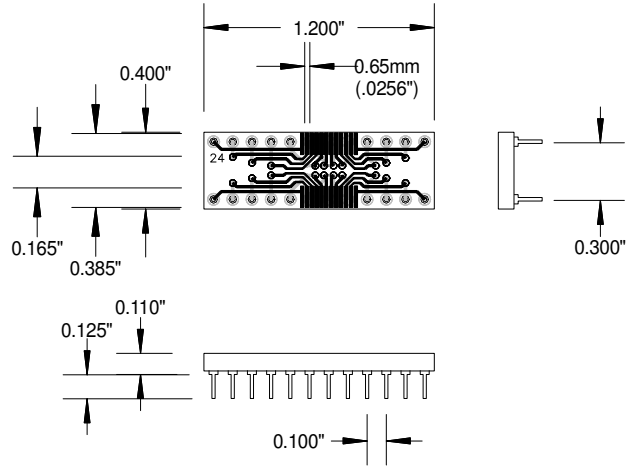

AK24D300-QSOP
24 PIN QSOP 0.025" PITCH TO DIP

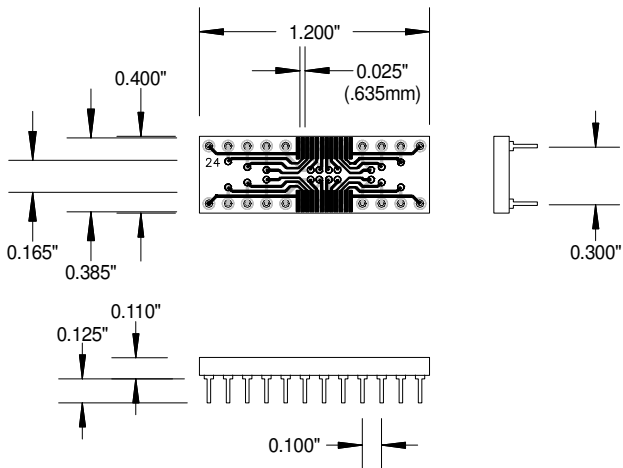

AK24D300-QFN/MLP 4X4
4MM-24 PIN QFN/MLP 0.5MM PITCH TO 0.300" DIP

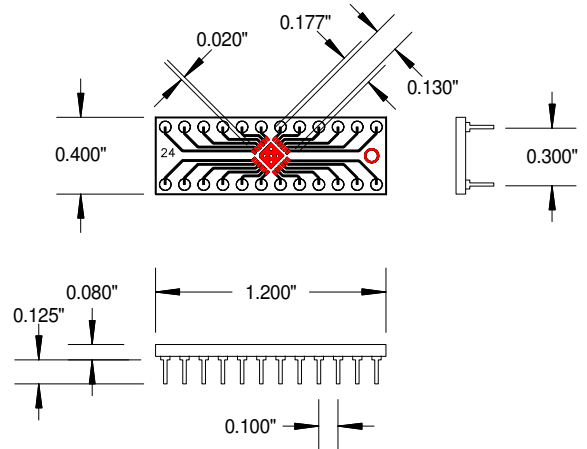

AK24D400-QFN/MLP 5X5
5MM-24 PIN QFN/MLP 0.65MM PITCH TO 0.400" DIP

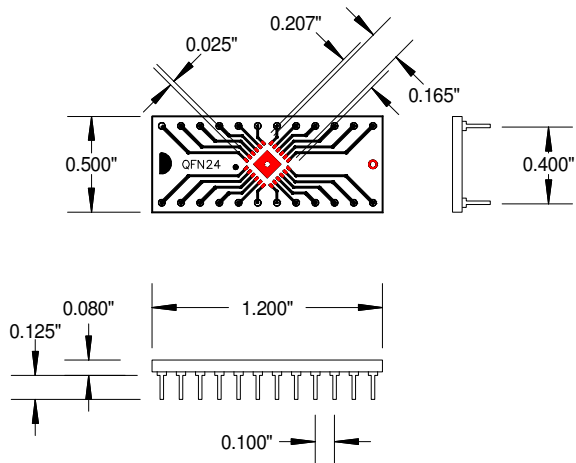

AK24D600-QFN/MLP 4X4
4MM-24 PIN QFN/MLP 0.5MM PITCH TO 0.600" DIP

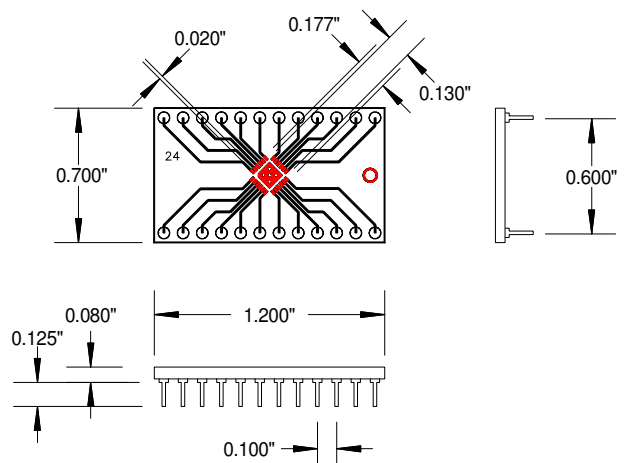

AK24D300-LLP

LEADLESS LEADFRAME PACKAGE(5 X 4)
TO 24 PIN DIP

