

DESCRIPTION

The Accutec AK48256 high density memory modules is a random access memory organized in 256K x 8 bit words. The assembly consists of eight standard 256K x 1 DRAMs in plastic leaded chip carriers (PLCC) mounted on the front side of a printed circuit board. The module can be configured as a leadless 30 pad SIM or a leaded 30 pin SIP. This packaging approach provides a 6 to 1 density increase over standard DIP packaging.

The operation of the AK48256 is identical to eight 256K x 1 DRAMs. The data input is tied to the data output and brought out separately for each device, with common $\overline{\text{RAS}}$, $\overline{\text{CAS}}$ and $\overline{\text{WE}}$ control. This common I/O feature dictates the use of early-write cycles to prevent contention of D and Q. Since the Write-Enable ($\overline{\text{WE}}$) signal must always go low before $\overline{\text{CAS}}$ in a write cycle, Read-Write and Read-Modify-Write operation is not possible.

FEATURES

- 262,144 by 8 bit organization
- Optional 30 Pad leadless SIM (Single In-Line Module) or 30 Pin leaded SIP (Single In-Line Package)
- JEDEC standard pinout
- Each device has common D and Q lines with common $\overline{\text{RAS}}$, $\overline{\text{CAS}}$ and $\overline{\text{WE}}$ control
- 2.8 Watt active and 180 mW standby (max)
- Operating free air temperature 0°C to 70°C
- Upward compatible with AK481024, AK581024, AK584096 and AK5816384
- Functionally and Pin compatible with AK58256A

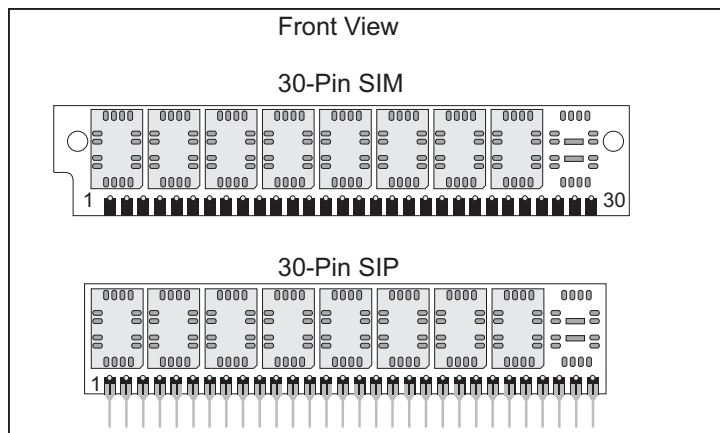

PIN NOMENCLATURE

A ₀ - A ₈	Address Inputs
DQ ₁ - DQ ₈	Data In / Data Out
$\overline{\text{CAS}}$	Column Address Strobe
$\overline{\text{RAS}}$	Row Address Strobe
$\overline{\text{WE}}$	Write Enable
V _{cc}	5v Supply
V _{ss}	Ground
NC	No Connect

PIN ASSIGNMENT

PIN #	SYMBOL	PIN #	SYMBOL
1	V _{cc}	16	DQ ₅
2	$\overline{\text{CAS}}$	17	A ₈
3	DQ ₁	18	NC
4	A ₀	19	NC
5	A ₁	20	DQ ₆
6	DQ ₂	21	$\overline{\text{WE}}$
7	A ₂	22	V _{ss}
8	A ₃	23	DQ ₇
9	V _{ss}	24	NC
10	DQ ₃	25	DQ ₈
11	A ₄	26	NC
12	A ₅	27	$\overline{\text{RAS}}$
13	DQ ₄	28	NC
14	A ₆	29	NC
15	A ₇	30	V _{cc}

FUNCTIONAL DIAGRAM

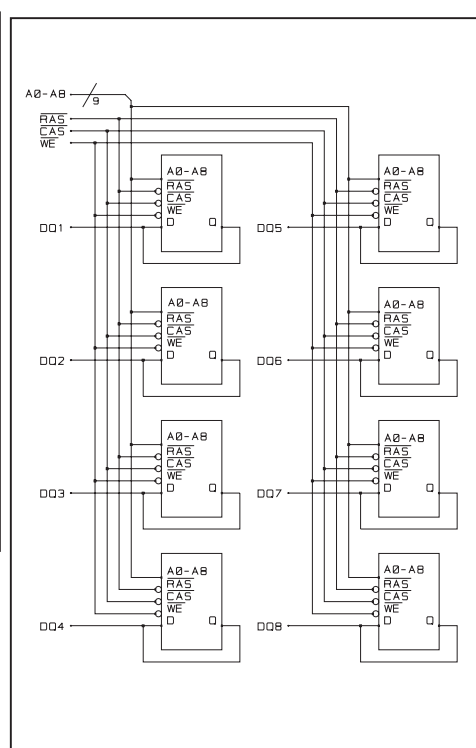

MODULE OPTIONS

Leadless SIM: AK48256S
Leaded SIP: AK48256G

ORDERING INFORMATION

PART NUMBER CODING INTERPRETATION

Position	1	2	3	4	5	6	7	8																				
1 Product	AK = Accutec Memory																											
2 Type	4 = Dynamic RAM 5 = CMOS Dynamic RAM 6 = Static RAM																											
3 Organization/Word Width	1 = by 1 16 = by 16 4 = by 4 32 = by 32 8 = by 8 36 = by 36 9 = by 9																											
4 Size/Bits Depth	64 = 64K 4096 = 4 MEG 256 = 256K 8192 = 8 MEG 1024 = 1 MEG 16384 = 16 MEG																											
5 Package Type	G = Single In-Line Package (SIP) S = Single In-Line Module (SIM) D = Dual In-Line Package (DIP) W = .050 inch Pitch Edge Connect Z = Zig-Zag In-Line Package (ZIP)																											
6 Special Designation	P = Page Mode N = Nibble Mode K = Static Column Mode W = Write Per Bit Mode V = Video Ram																											
7 Separator	- = Commercial 0°C to +70°C M = Military Equivalent Screened (-55°C to +125°C) I = Industrial Temperature Tested (-45°C to +85°C) X = Burned In																											
8 Speed (first two significant digits)	<table border="0"> <tr> <td>DRAMS</td> <td>SRAMS</td> <td></td> <td></td> </tr> <tr> <td>50 = 50 nS</td> <td>8 = 8 nS</td> <td></td> <td></td> </tr> <tr> <td>60 = 60 nS</td> <td>10 = 10 nS</td> <td></td> <td></td> </tr> <tr> <td>70 = 70 nS</td> <td>12 = 12 nS</td> <td></td> <td></td> </tr> <tr> <td>80 = 80 nS</td> <td>15 = 15 nS</td> <td></td> <td></td> </tr> </table>								DRAMS	SRAMS			50 = 50 nS	8 = 8 nS			60 = 60 nS	10 = 10 nS			70 = 70 nS	12 = 12 nS			80 = 80 nS	15 = 15 nS		
DRAMS	SRAMS																											
50 = 50 nS	8 = 8 nS																											
60 = 60 nS	10 = 10 nS																											
70 = 70 nS	12 = 12 nS																											
80 = 80 nS	15 = 15 nS																											

The numbers and coding on this page do not include all variations available but are show as examples of the most widely used variations. Contact Accutec if other information is required.

EXAMPLES:

AK48256SP-10

256K x 8, 100 nSEC DRAM 30 pin SIM Configuration, Page Mode

AK48256GK-80

MECHANICAL DIMENSIONS

Inches

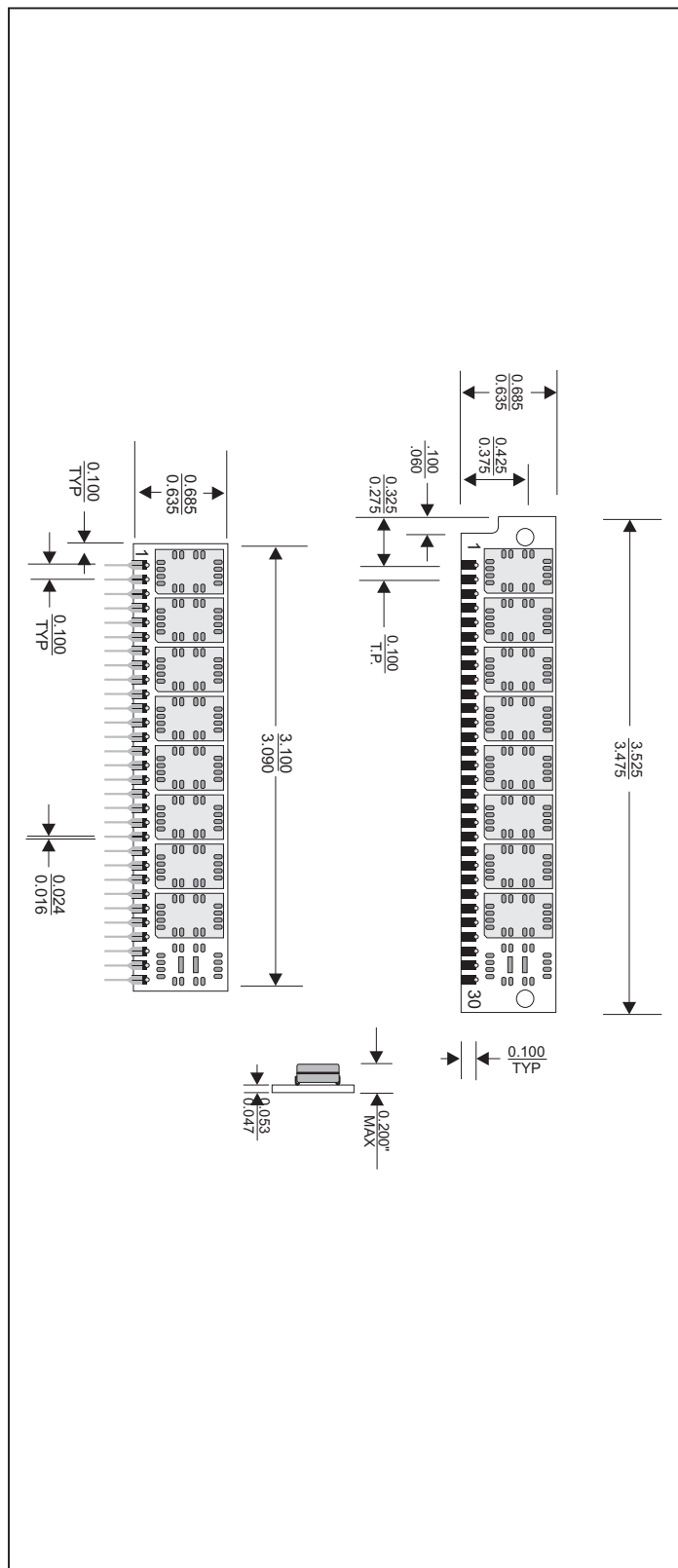

Accutec reserves the right to make changes in specifications at any time and without notice. Accutec does not assume any responsibility for the use of any circuitry described; no circuit patent licenses are implied. Preliminary data sheets contain minimum and maximum limits based upon design objectives, which are subject to change upon full characterization over the specific operating conditions.



5 NEW PASTURE ROAD
NEWBURYPORT, MA 01950-4040
PHONE: 978-465-6200 FAX: 978-462-3396
Email: sales@accutekmicro.com
Internet: www.accutekmicro.com