

Bluetooth® Module

WML-C46 Class 2

OUTLINE

This is a wireless communications module that conforms to Bluetooth® Ver.2.0+EDR.

Applications include headsets, digital cameras, PC peripheral devices, PDA, etc.

*The Bluetooth® word mark and logos are owned by the Bluetooth SIG, Inc.

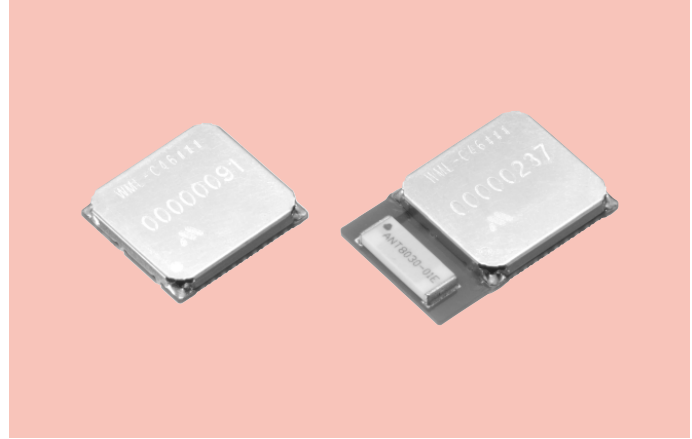

FEATURES

1. Equipped with multiple programmable I/O pins to meet various application needs.
2. RFCOMM Stack enables mounting of Headset Profile, Serial Port Profile, etc.
3. Ultra-small size and thinness achieved through use of high density mounting technology.
4. UART and PCM interfaces allow realization of a wide variety of applications.
5. 8Mbits of Flash-ROM allow realization of a wide variety of applications.
6. Conforms to EMI standards worldwide, including FCC and CE.
7. Supports Bluetooth® Class 2.
8. Operating temperature range: -40~+85°C.

SPECIFICATIONS

Item		Specifications
Reception Frequency		2402 ~ 2480MHz
Modulation		FHSS/GFSK, $\pi/4$ DPSK, 8DPSK
Channel Intervals		1MHz
Number of Channels		79CH
Power Supply Voltage		2.8 ~ 3.4V
Current Consumption		50mA typ.
Transmission Rate		2178kbps
Receive Sensitivity		-82dBm typ.
Output Level (Class2)		+4dBm max.
Dimensions	Without an antenna	11.8(W)×12.6(D)×1.9(H)mm
	With an antenna	11.8(W)×17.6(D)×1.9(H)mm

DIMENSIONS

●WML-C46 (Without an antenna)

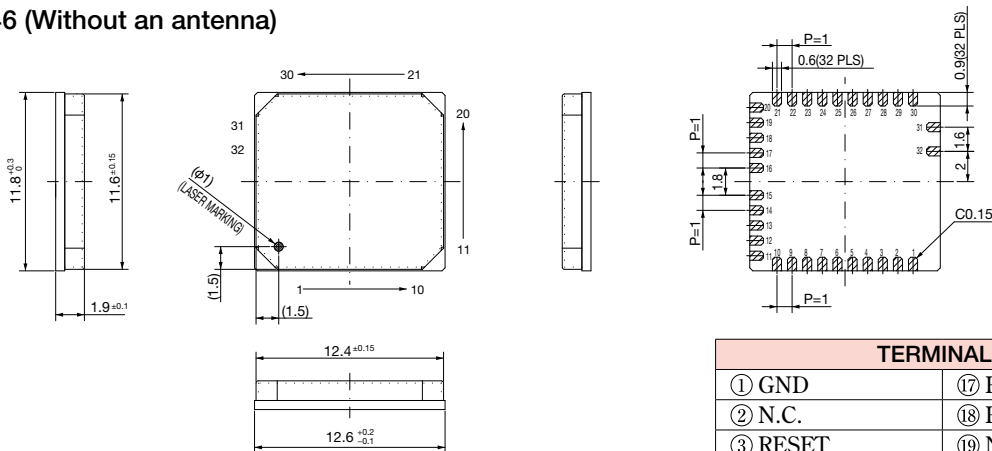

TERMINALS	
① GND	⑰ PCM_SYNC
② N.C.	⑱ PCM_OUT
③ RESET	⑲ N.C.
④ AIO[1]	⑳ GND
⑤ SPI_MISO	㉑ AIO[0]
⑥ SPI_CSB	㉒ PIO[9]
⑦ PCM_CLK	㉓ PIO[2]
⑧ SPI_MOSI	㉔ PIO[5]
⑨ VDD	㉕ PIO[6]
⑩ GND	㉖ PIO[3]
⑪ UART_CTS	㉗ PIO[8]
⑫ UART_RTS	㉘ PIO[4]
⑬ UART_TX	㉙ PIO[7]
⑭ UART_RX	⑳ GND
⑮ PCM_CLK	㉑ ANT
⑯ PCM_IN	㉒ GND

●WML-C46 (With an antenna)

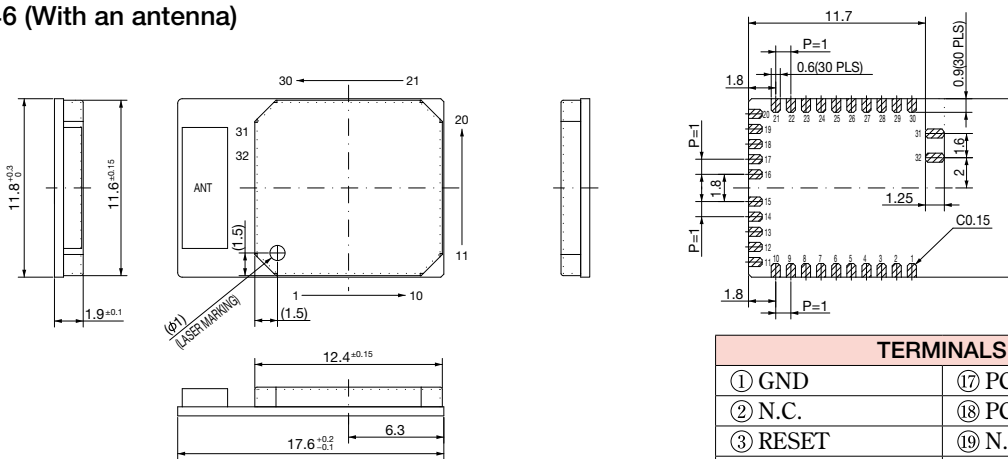

TERMINALS	
① GND	⑰ PCM_SYNC
② N.C.	⑱ PCM_OUT
③ RESET	⑲ N.C.
④ AIO[1]	⑳ GND
⑤ SPI_MISO	㉑ AIO[0]
⑥ SPI_CSB	㉒ PIO[9]
⑦ PCM_CLK	㉓ PIO[2]
⑧ SPI_MOSI	㉔ PIO[5]
⑨ VDD	㉕ PIO[6]
⑩ GND	㉖ PIO[3]
⑪ UART_CTS	㉗ PIO[8]
⑫ UART_RTS	㉘ PIO[4]
⑬ UART_TX	㉙ PIO[7]
⑭ UART_RX	⑳ GND
⑮ PCM_CLK	㉑ N.C(RF_TEST: ANT)
⑯ PCM_IN	㉒ N.C(RF_TEST: GND)

Unit : mm

• Any products mentioned in this catalog are subject to any modification in their appearance and others for improvements without prior notification.
 • The details listed here are not a guarantee of the individual products at the time of ordering. When using the products, you will be asked to check their specifications.