

Stepping Motors

M42SP-6NK

OUTLINE

A model with high response in $\phi 42$ series.



FEATURES

1. High response.
2. High-output torque.
3. Superior running quietness and stability.

USES

Printers, multifunction machines, copy machines, FAX, etc.

SPECIFICATIONS

Item	M42SP-6NK	
Rated Voltage	DC 12V	DC 24V
Working Voltage	DC 10.8~13.2V	DC 21.6~26.4V
Rated Current/Phase	400mA(PEAK)	
No. of Phase	2 Phase	
Coil DC Resistance	5Ω/phase±7%	
Step Angle	7.5°/step	
Excitation Method	2-2 Phase excitation (Bipolar driving)	
Insulation Class	Class E insulation	
Holding Torque	39.2mN·m	39.2mN·m
Pull-out Torque	23.2mN·m/800pps	17.4mN·m/2,000pps
Pull-in Torque	27.1mN·m/200pps	26.2mN·m/200pps
Max. Pull-out Pulse Rate	2,000pps	3,900pps
Max. Pull-in Pulse Rate	700pps	700pps

CHARACTERISTICS

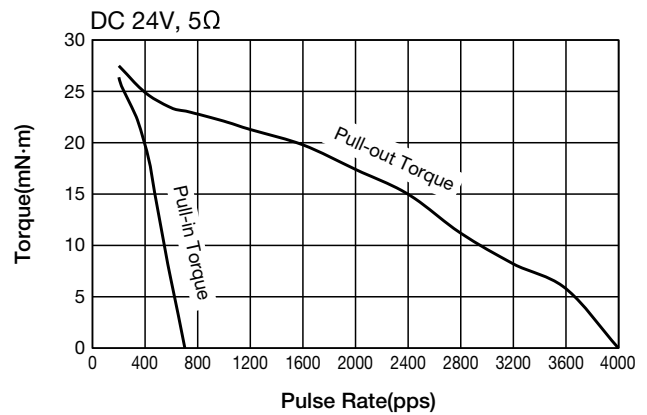
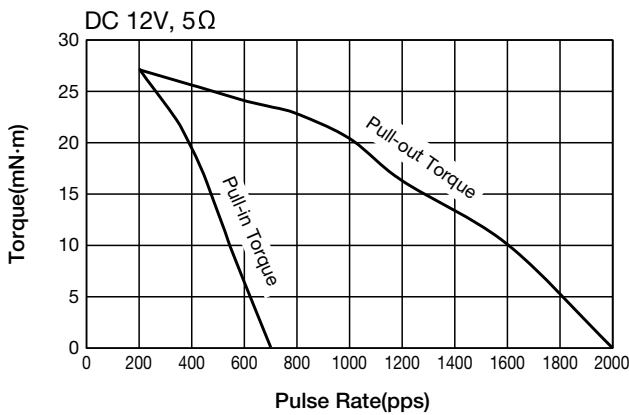

DIMENSIONS

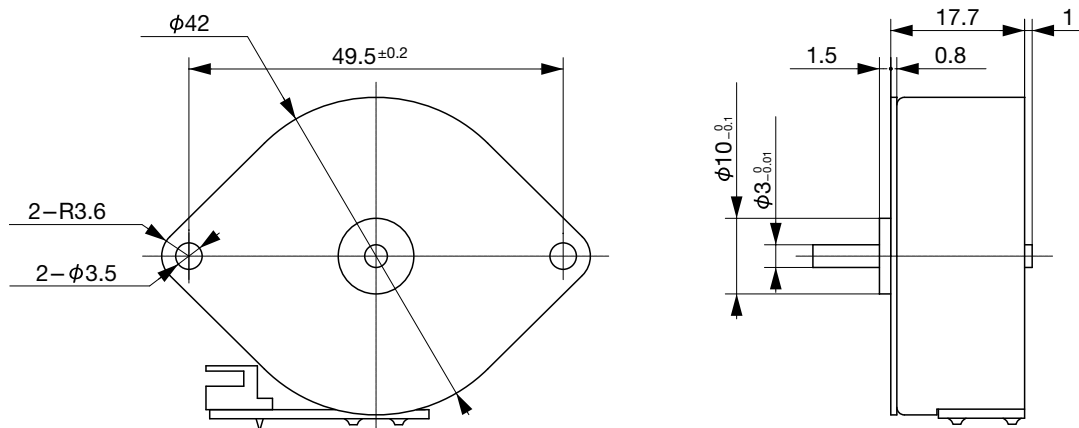

Unit : mm
General tolerance : ±0.5