

# Multi-Function Tactile Switches SOQ Series

## FEATURES

1. Minimized mounting area.
2. 1-pole, 5-contacts structure is adopted so that switches in this series can be used in a comparator circuit.
3. Long life and enhanced tactile feeling by unique 2 layer construction.
4. 4 direction operation and center click switch.
5. Suitable for SMT reflow soldering.

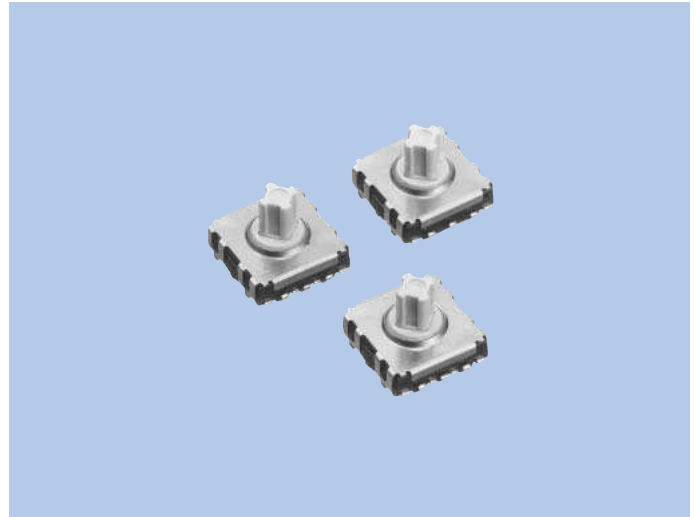

## APPLICATIONS

1. For mobile phones, DSCs, Game equipment and PDAs.

## MODEL NAME CODE

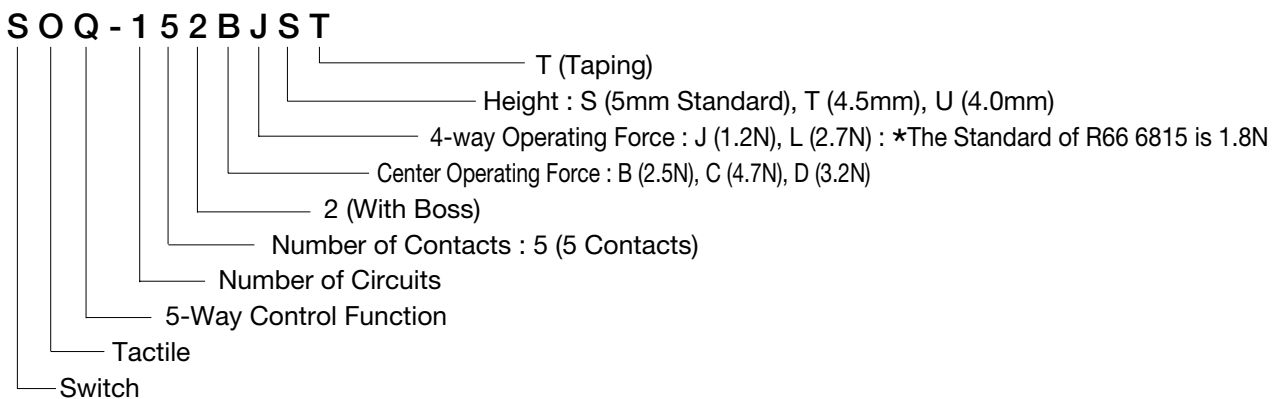

## SPECIFICATIONS

Electrical Characteristics	Rating		50mA, 12V DC
	Contact Resistance		200mΩ or less
	Insulation Resistance		100MΩ or more
	Withstand Voltage		1 minute at 100V
Mechanical Characteristics	4-Way	J Type	1.2N *The Standard of R66 6815 is 1.8N
		L Type	2.7N
	Center	B Type	2.5N
		C Type	4.7N
		D Type	3.2N
Life	BJ Type	200,000cycles	
	CL Type	100,000cycles	
	DJ Type	100,000cycles	

• Any products mentioned in this catalog are subject to any modification in their appearance and others for improvements without prior notification.  
 • The details listed here are not a guarantee of the individual products at the time of ordering. When using the products, you will be asked to check their specifications.

TYPE

Model Name Code	Order Number	Operating Force		Number of Contacts	Mounting Height (h)	Pcs/Reel
		Center	4-Way			
SOQ-152BJST	R66 6538	2.5N	1.2N	5	5.0mm	1,000
SOQ-152BJTT	R66 6539	2.5N	1.2N	5	4.5mm	1,000
SOQ-152CLST	R66 6540	4.7N	2.7N	5	5.0mm	1,000
SOQ-152CLTT	R66 6541	4.7N	2.7N	5	4.5mm	1,000
SOQ-152DJST	R66 6542	3.2N	1.2N	5	5.0mm	1,000
SOQ-152DJTT	R66 6543	3.2N	1.2N	5	4.5mm	1,000
SOQ-152BJUT	R66 6815	2.5N	1.8N	5	4.0mm	1,000

DIMENSIONS

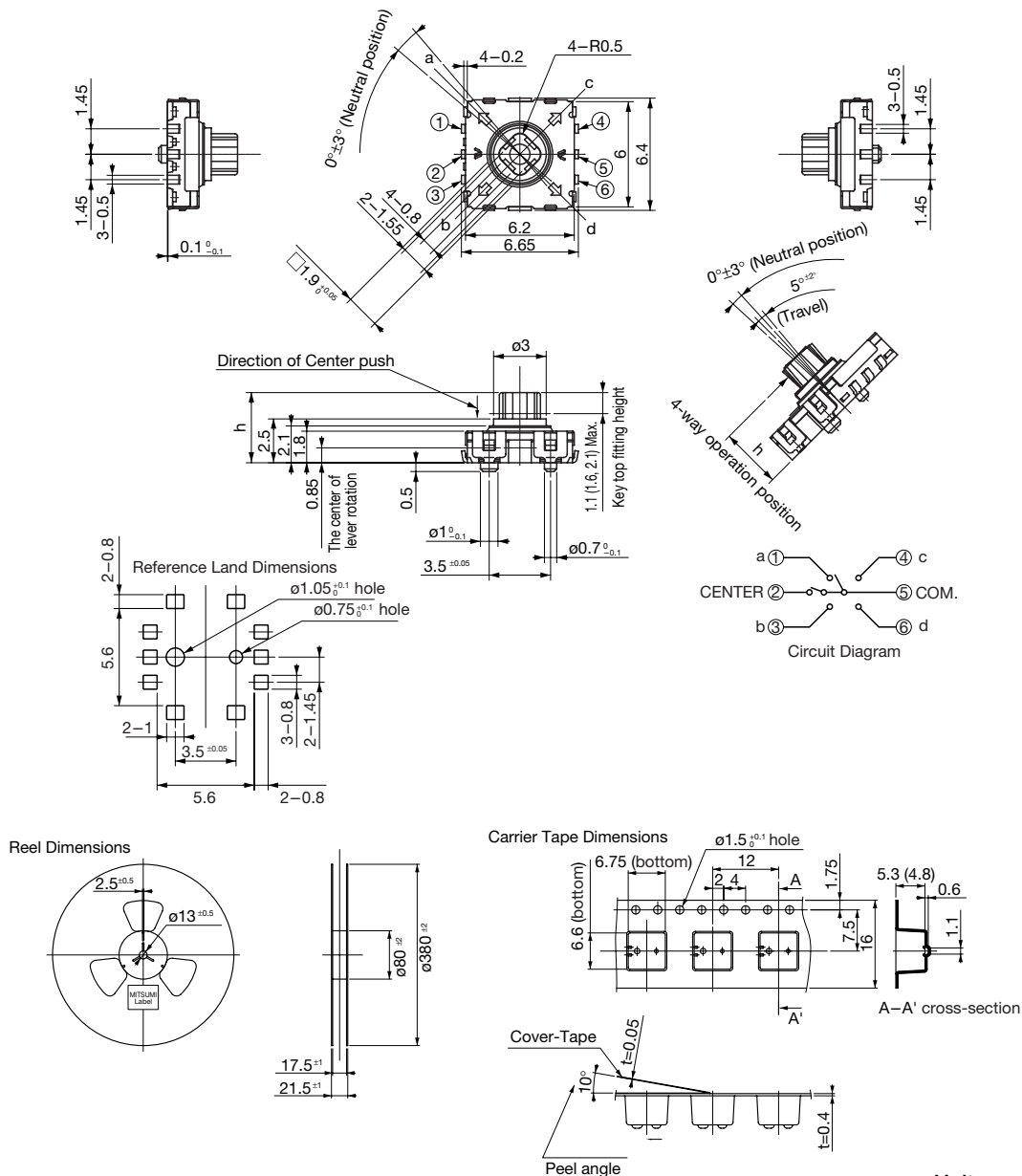

\*One reel accommodates 1,000 pieces (Ø380).  
Inside ( ), 4.5mm specification.

Unit : mm  
☆Tolerance : ±0.3mm

• Any products mentioned in this catalog are subject to any modification in their appearance and others for improvements without prior notification.  
• The details listed here are not a guarantee of the individual products at the time of ordering. When using the products, you will be asked to check their specifications.