

# Small Type Tactile Switches SOG Series

## FEATURES

1. Original terminal structure reduces the mounting area.
2. High Reliability thanks to the dust-proof design.
3. Good feeling from the wider pressing range.

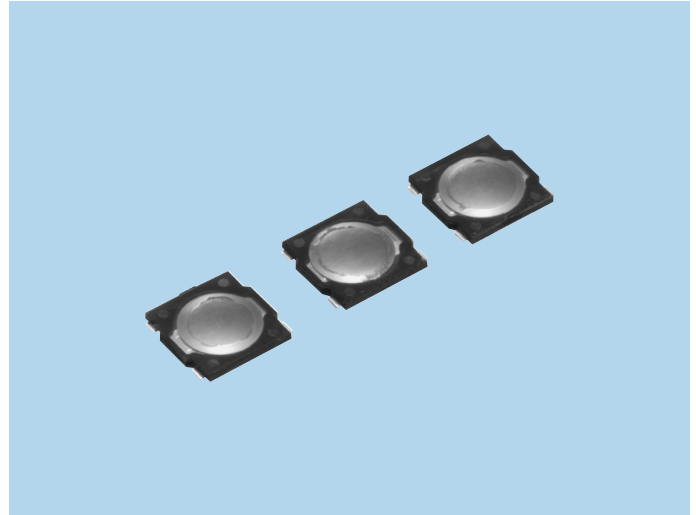

## APPLICATIONS

Mobile Phones, Smartphones, Digital Cameras, Game Machines and etc.

## MODEL NAME CODE

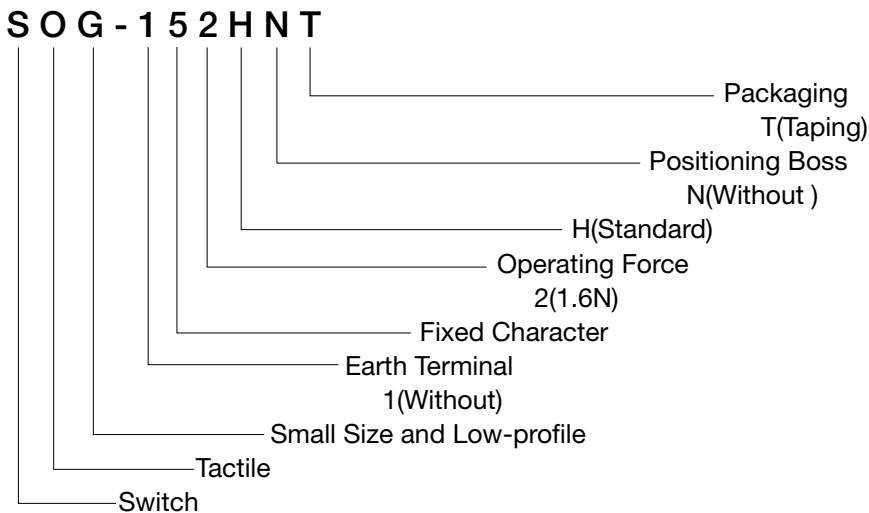

## SPECIFICATIONS

Electrical Characteristics	Rating	DC12V, 50mA
	Contact Resistance	1Ω or less
	Insulation Resistance	10MΩ or more
	Withstand Voltage	1 minute at AC 100V
Life		500,000 times

## TYPE

Model Name Code	Model Name	Operating Force	Boss	Pcs/Reel
SOG-152HNT	R 66 7346	1.6N	Without	10,000

## DIMENSIONS

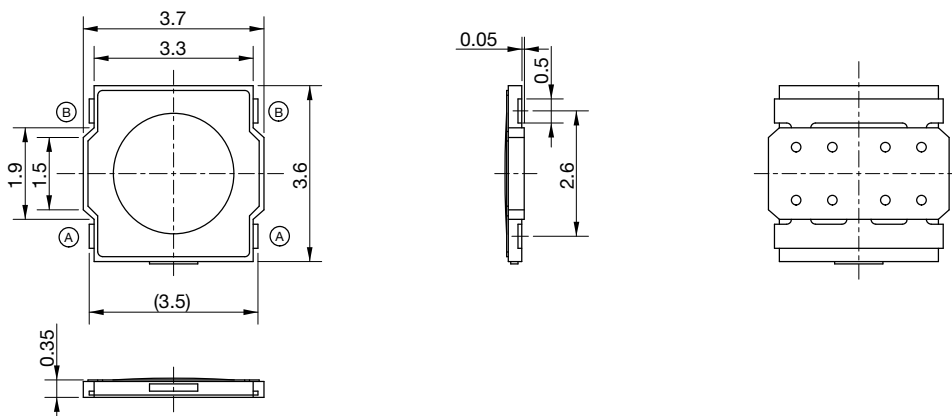

Reference Land Dimensions

Circuit Diagram

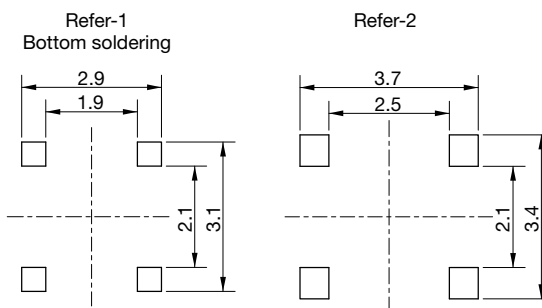
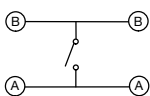

Unit:mm