

# Small Type Tactile Switches SOL Series

## FEATURES

1. Good feeling with the NUB.
2. Suitable for high load support (3.3N)
3. High Reliability with the small, thin, and dust-proof design.

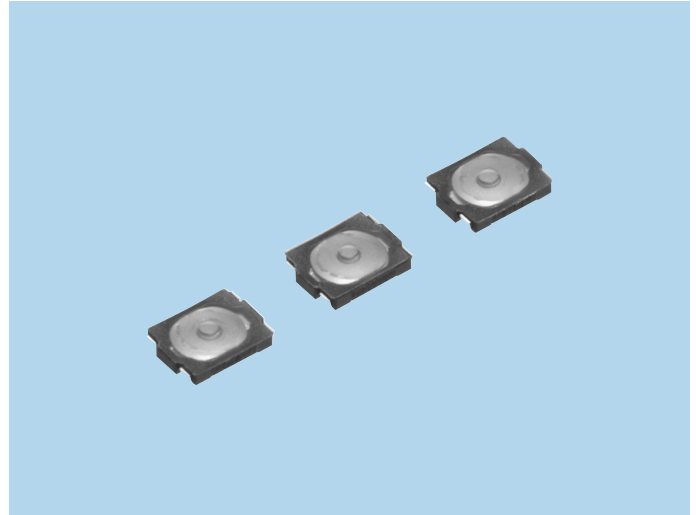

## APPLICATIONS

Automotive Equipment, Mobile Phones, Smartphones, Digital Cameras, Game Machines and etc.

## MODEL NAME CODE

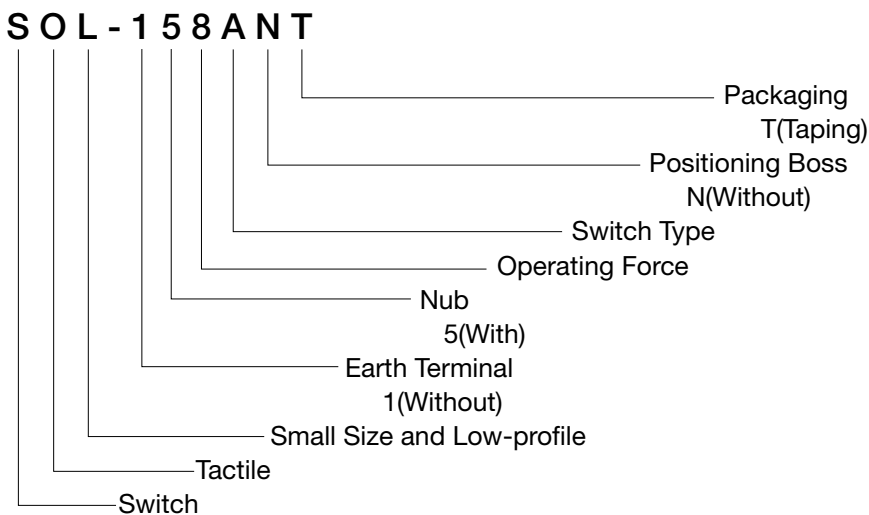

## SPECIFICATIONS

Electrical Characteristics	Rating	DC15V, 20mA
	Contact Resistance	500mΩ or less
	Insulation Resistance	50MΩ or more
	Withstand Voltage	1 minute at AC 100V
Life		100,000 times

## TYPE

Model Name Code	Model Name	Operating Force	Boss	Pcs/Reel
SOL-151ANT	R 66 7465	1.2N	Without	10,000
SOL-152ANT	R 66 7477	1.6N	Without	10,000
SOL-154ANT	R 66 7471	2.4N	Without	10,000
SOL-158ANT	R 66 7470	3.3N	Without	10,000

## DIMENSIONS

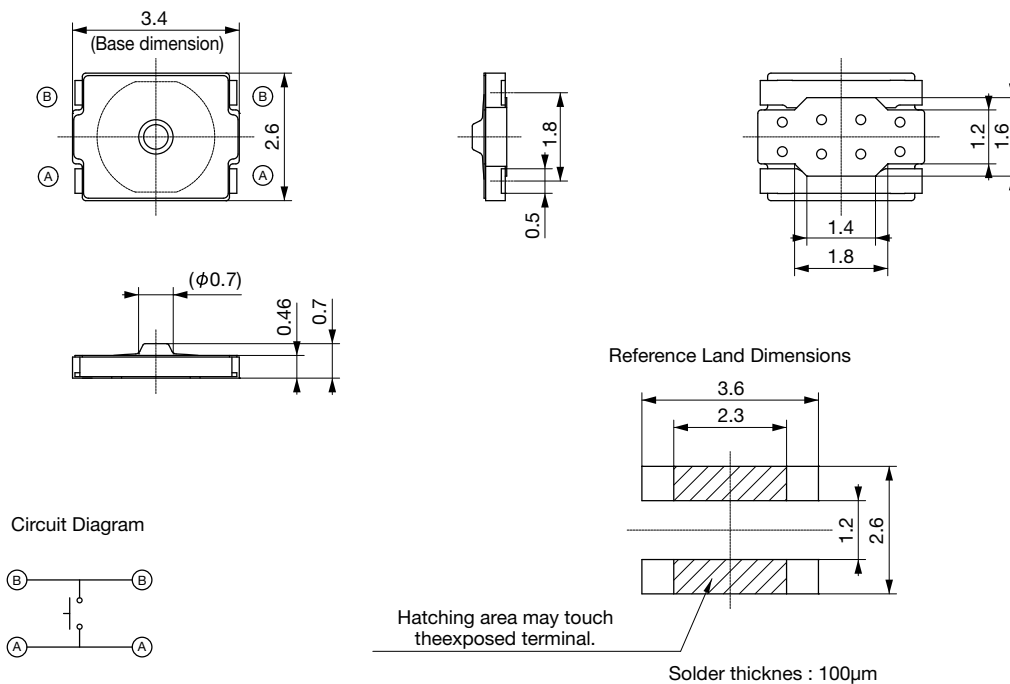

Unit:mm