

# Power Supply Voltage & Signal CAM-C75, CCM-C76

## FEATURES

1. 16 pin power connector of an angle type on the plug side.
2. One-touch locking mechanism ensures a secure fitting.
3. The socket connector on the cable assembly side is of double lance structure to enhance the withdrawal strength from the housing.
4. Configured for 4 power supply contact pins and 12 signal contact pins.

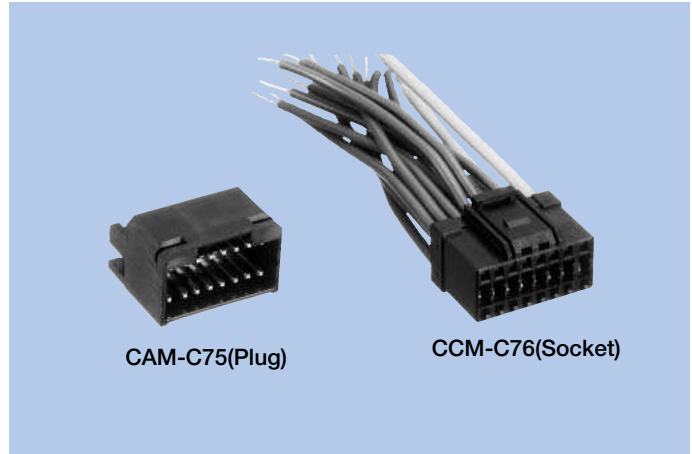

CAM-C75(Plug)

CCM-C76(Socket)

## HOW TO ORDER

### 1.CAM-C75 (Plug)

**C75-016-02 0-I J B A A**  
 1     2     3     4     5     6     7     8     9

- 1 Series No. (C75)
- 2 No. of contacts (016 : 16pins)
- 3 Housing material (02 : PBT resin)
- 4 Housing UL grade (0 : UL94V-0)
- 5 Contact plating (I : Tin reflow plating)
- 6 Contact plating thickness (J : 3.0μm)
- 7 Contact tail style (B : Angle)
- 8 Accessory for connector outside (A : none)
- 9 Accessory for connector inside (A : none)

### 2.CCM-C76 (Socket)

**C76-016-**      
 1     2     3

- 1 Series No. (C76)
- 2 No. of contacts (016 : 16pins)
- 3 Running No. assigned by us

## SPECIFICATIONS

### ELECTRICAL CHARACTERISTICS

Rated Voltage	14V DC
Rated Current	Signal terminal : 5A (Power supply terminal : 7A)
Withstanding Voltage	500V AC (rms) 1minute
Insulation Resistance	100MΩ min. (at 500V DC)
Contact Resistance	15mΩ max.

### MECHANICAL CHARACTERISTICS

Life (Matching Cycle)	200 times
Total Insertion Force	78.4N (8kgf) max.
Total Withdrawal Force	9.8N (1kgf) min.
Using Temperature Range	-30~+85°C

## MATERIAL & FINISH

Component Parts		Material	Finish
CAM-C75 (Plug)	Housing	Glass filled PBT resin	—
	Contact	Brass	Tin reflow plating
CCM-C76 (Socket)	Housing	46 Nylon	—
	Contact for Power Supply	Copper Alloy	Tin reflow plating
	Contact for Signal	Copper Alloy	Tin reflow plating

## DIMENSIONS

CAM-C75

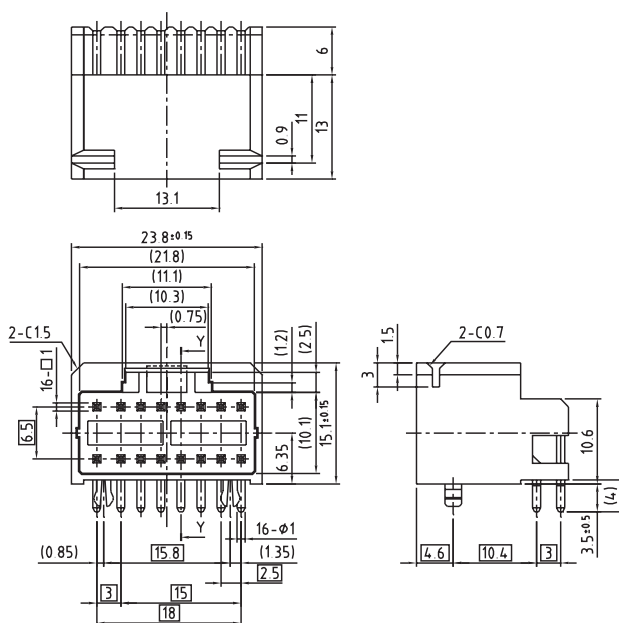

CCM-C76

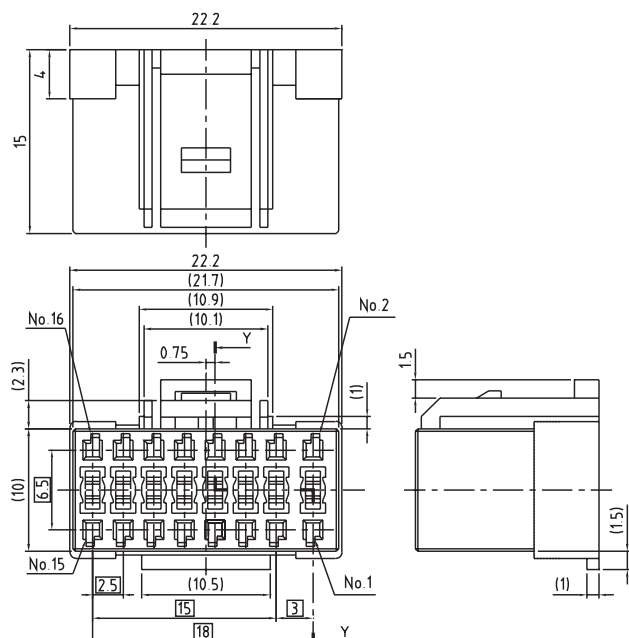

Unit : mm