

Interface Connectors for Cradle CAM-F34, F35 Series

FEATURES

1. Developed for connection of portable equipment with cradles.
2. 30 pins specification, with 15 pins arranged in two rows at an 0.5 mm pitch.
3. Provided with shutter cover to prevent dust and electrostatic discharge on the receptacle side. (F34)
4. It is generated when plugs are united with the receptacle, and there is a mechanism that absorbs shaking (length and side).
5. SMT-compatible.
6. Gold-plated shield case.

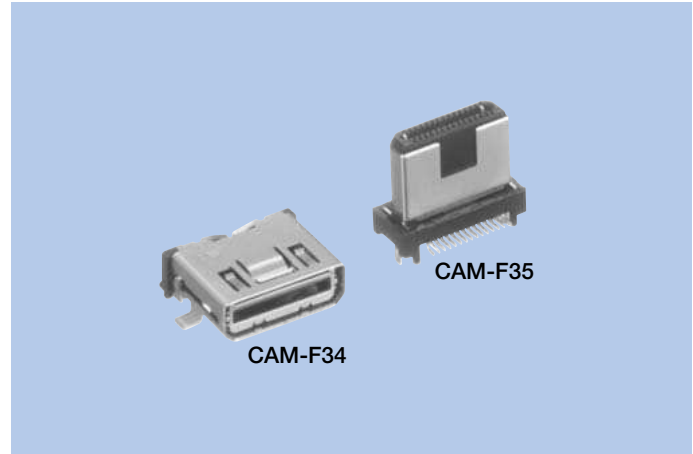

HOW TO ORDER

1.CAM-F34

F34-030-21 0-A G G A A
 1 2 3 4 5 6 7 8 9

- 1 Series No. (F34)
- 2 No. of contacts (030 : 30pins)
- 3 Housing material (21 : LCP resin)
- 4 UL grade (0 : UL 94V-0)
- 5 Contact plating
(A : Gold)
- 6 Contact plating thickness (G : 0.3μm)
- 7 Contact read style (G : Angle)
- 8 Coupling side accessories (A : None)
- 9 Board side accessories (A : None)

2.CAM-F35

F35-030-21 0-A G E A A
 1 2 3 4 5 6 7 8 9

- 1 Series No. (F35)
- 2 No. of contacts (030 : 30pins)
- 3 Housing material (21 : LCP resin)
- 4 UL grade (0 : UL 94V-0)
- 5 Contact plating
(A : Gold)
- 6 Contact plating thickness (G : 0.3μm)
- 7 Contact read style (E : Straight SMT)
- 8 Coupling side accessories (A : None)
- 9 Board side accessories (A : None)

SPECIFICATIONS

ELECTRICAL CHARACTERISTICS

Maximum allowable Voltage	30V
Maximum allowable current	0.5A
Withstanding Voltage	125V AC (rms) 1minute
Insulation Resistance	10MΩ min. (Initial 150V DC)
Contact Resistance	55mΩ max.

MECHANICAL CHARACTERISTICS

Life (Matching Cycle)	5,000times
Total Insertion Force	44.1N (4.5kgf) max.
Total Decoupling force	24.5N (2.5kgf) max.
Using Temperature Range	-20~+60°C

MATERIAL & FINISH

	Component Parts	Material	Finish
CAM-F34	Housing	LCP resin	Black
	Contact	Copper Alloy	Gold plating
	Shielded Case	Copper Alloy	Gold plating
	Shutter Housing	LCP resin	Black
	Shutter Shielded	SUS	—
	Coil Spring	Piano wire	—
	Support Plate	LCP resin	Black
CAM-F35	Housing	LCP resin	Black
	Contact	Copper Alloy	Gold plating
	Shielded Case	Copper Alloy	Gold plating

DIMENSIONS

CAM-F34

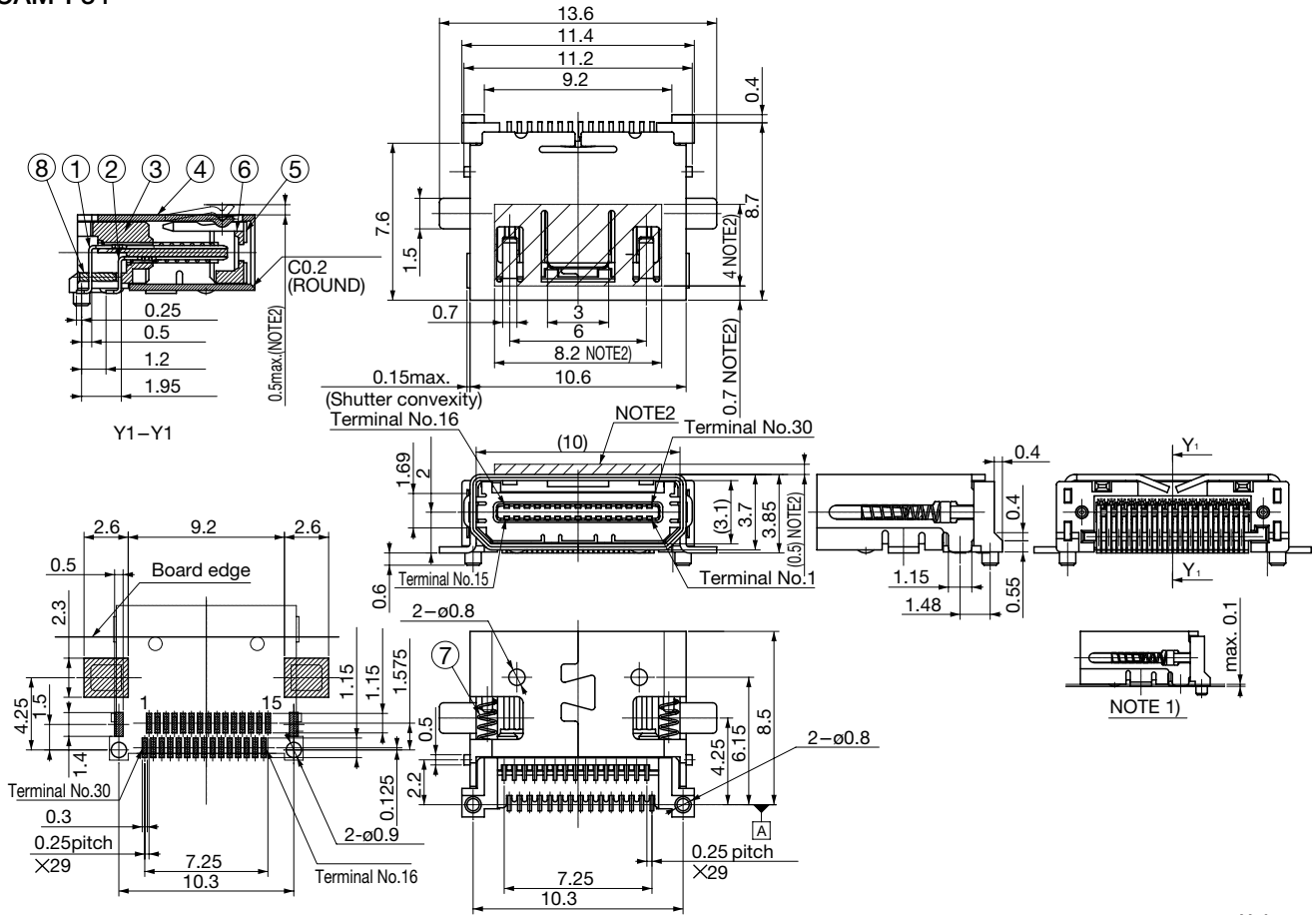

Unit : mm

NOTE

- 1) COPLANARITY: max.01
- 2) As for the illustration range, opening the space with equal to or more than 0.5mm height.
- 3) The inveigling size is 0.4 mm to the direction of Y and X.
- 4) The connector to apply is CAM-F35 or IAP-F35. As for close fitting of CAM-F34 and CAM-F35 or CAM-F34 and IAP-F35, it guarantees.

CAM-F35

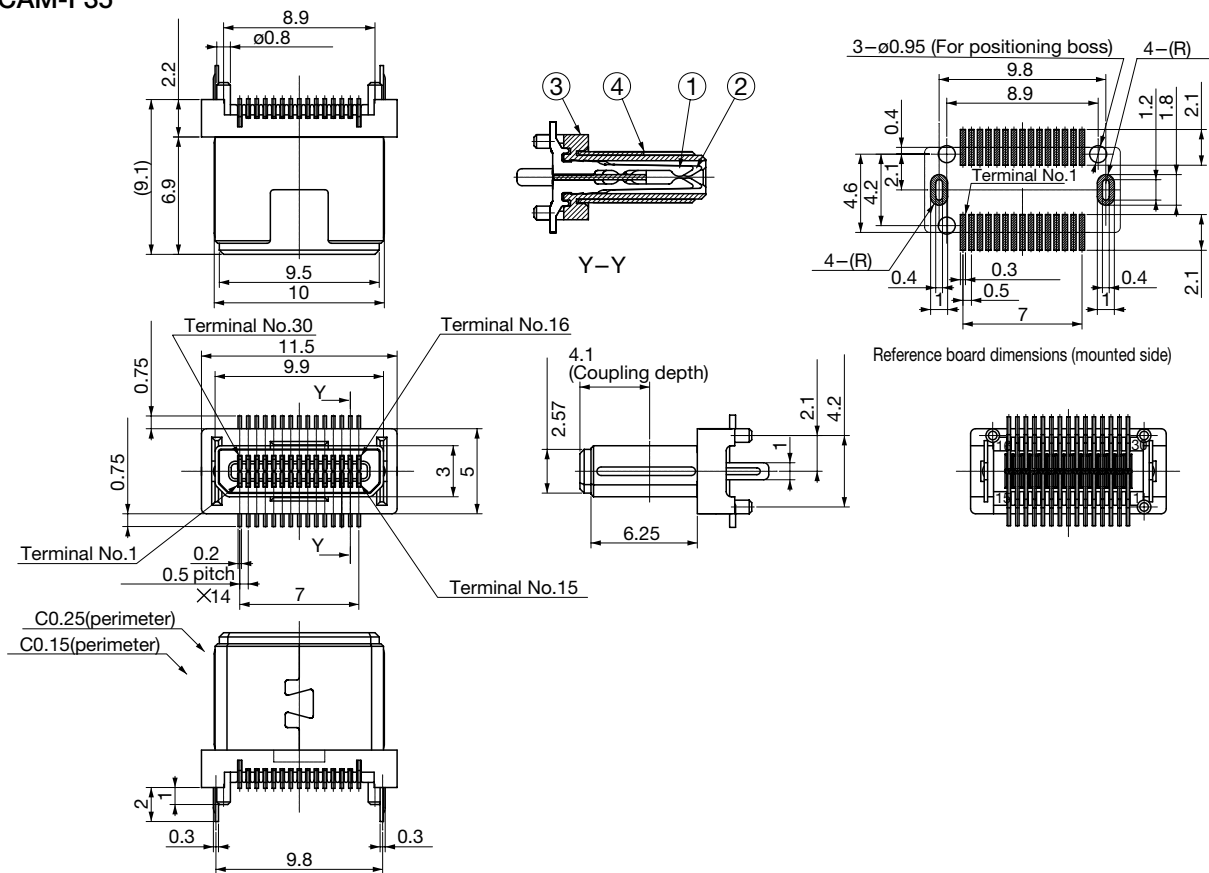

Unit : mm

• Any products mentioned in this catalog are subject to any modification in their appearance and others for improvements without prior notification.
 • The details listed here are not a guarantee of the individual products at the time of ordering. When using the products, you will be asked to check their specifications.