

# Power Inductors CK Series

## OUTLINE

High efficiency and Low DCR power inductor for battery-driven portable electric equipment power supplies (DC-DC converter, switching power supply) and other electronic equipment.

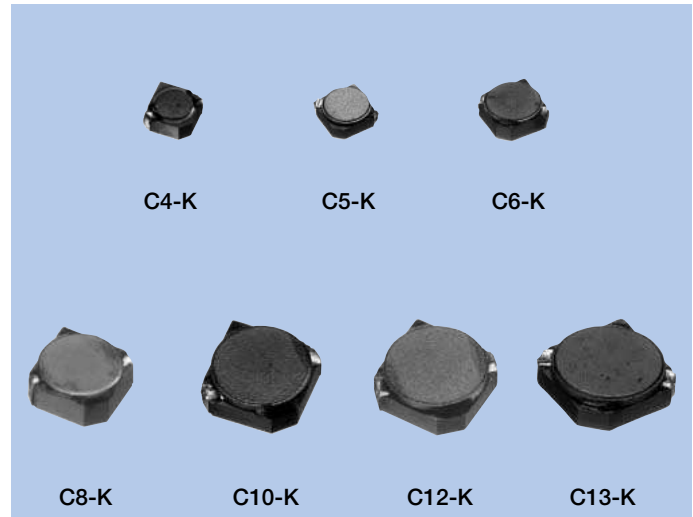

## FEATURES

1. Low DCR
2. Low profile and high current
3. Magnetically shielded structure for electromagnetic interference

## APPLICATIONS

For DSCs, DVD/MP3 Players, Mobile Phones, PDAs, Notebook Computers, LCD TVs, PDP TVs, Car Navigations, and other electronic equipment.

## SPECIFICATIONS

Type	Size (mm)	H length (mm)	Inductance (μH)	Operational Frequency (kHz)	Rated Current (A)	DC Resistance (mΩ)	Pcs/Reel
C4-K1.8R	4.8×4.8	1.9	1.0~150	10~500	0.22~2.40	18~1,420	2,000
C4-K1.8RA	4.8×4.8	1.9	1.0~150	10~500	0.31~3.50	22~2,100	2,000
C4-K3L	4.8×4.8	3.0	1.0~150	10~500	0.20~1.95	12~485	2,000
C4-K3LA	4.8×4.8	3.0	1.0~150	10~500	0.36~3.00	13~976	2,000
C5-K1.8L	5.6×5.6	1.9	1.0~150	10~500	0.28~3.90	10~1,083	2,000
C5-K1.8LA	5.6×5.6	1.8	1.2~150	10~500	0.30~3.10	17~1,452	2,000
C5-K3LGA	5.6×5.6	3.0	1.2~820	10~500	0.15~5.00	17~3,800	2,000
C6-K1.8L	6.6×6.6	2.0	1.0~150	10~500	0.48~5.00	24~1,300	1,000
C6-K3LG	6.6×6.6	3.2	1.0~1,000	10~500	0.21~6.30	8~3,800	1,000
C6-K5LGA	6.6×6.6	5.0	1.2~3,300	10~500	0.23~9.00	10~10,700	500
C6-K5RA	6.6×6.6	5.0	1.5~100	10~500	1.1~8.5	14~390	700
C8-K4L	8×8	4.0	1.0~150	10~500	0.73~7.00	10~421	500
C8-K5L	8×8	5.0	1.0~5,600	10~500	0.11~7.00	10~14,000	500
C8-K5LA	8×8	5.0	1.2~150	10~500	1.10~10.30	11~438	500
C10-K4L	10×10	4.0	1.0~4,700	10~500	0.15~7.10	11~12,700	500
C12-K4.5L	11.5×11.5	4.5	1.0~150	10~500	1.20~7.10	7~430	500
C12-K7.5L	11.5×11.5	7.5	1.0~5,600	10~500	0.28~23.5	6~5,500	400
C13-K4.5L	13×13	4.5	1.0~150	10~500	1.33~11.0	8~339	500

## DATA LIST (C4-K1.8R Series)

C4-K1.8R (Height : 1.9mm max.)

Item	Stamp	Inductance			DCR (mΩ) typ.	DC Current (A)	
		(μH)	Tolerance (%)	Test Freq. (kHz)		Inductance -10% typ.	Temp. Δ25K typ.
DA	1R0	1.0	±30	1kHz	18	2.40	3.20
DC	1R5	1.5	±30	1kHz	23	2.20	2.70
DE	2R2	2.2	±30	1kHz	29	2.00	2.40
DF	2R7	2.7	±30	1kHz	34	1.80	2.30
DG	3R3	3.3	±30	1kHz	39	1.70	2.20
DH	3R9	3.9	±30	1kHz	53	1.50	2.10
DJ	4R7	4.7	±30	1kHz	57	1.40	1.90
DK	5R6	5.6	±30	1kHz	65	1.30	1.80
DL	6R8	6.8	±30	1kHz	82	1.10	1.60
DM	8R2	8.2	±30	1kHz	95	1.05	1.55
EA	100	10	±20	1kHz	110	0.90	1.25
EB	120	12	±20	1kHz	117	0.85	1.20
EC	150	15	±20	1kHz	165	0.75	1.10
ED	180	18	±20	1kHz	185	0.70	1.05
EE	220	22	±20	1kHz	212	0.60	1.00
EF	270	27	±20	1kHz	288	0.55	0.80
EG	330	33	±20	1kHz	345	0.50	0.70
EH	390	39	±20	1kHz	487	0.45	0.60
EJ	470	47	±20	1kHz	545	0.40	0.55
EK	560	56	±20	1kHz	595	0.35	0.53
EL	680	68	±20	1kHz	693	0.32	0.50
EM	820	82	±20	1kHz	850	0.30	0.45
FA	101	100	±20	1kHz	1,030	0.27	0.38
FB	121	120	±20	1kHz	1,260	0.24	0.32
FC	151	150	±20	1kHz	1,420	0.22	0.30

## DATA LIST (C4-K1.8RA Series)

C4-K1.8RA (Height : 1.9mm max.)

Item	Stamp	Inductance			DCR (mΩ) typ.	DC Current (A)	
		(μH)	Tolerance (%)	Test Freq. (kHz)		Inductance -10% typ.	Temp. Δ25K typ.
DA	1R0	1.0	±30	1kHz	22	3.50	2.30
DC	1R5	1.5	±30	1kHz	26	3.10	2.10
DD	1R8	1.8	±30	1kHz	32	2.80	2.00
DF	2R7	2.7	±30	1kHz	39	2.20	1.80
DG	3R3	3.3	±30	1kHz	52	2.10	1.50
DH	3R9	3.9	±30	1kHz	70	2.00	1.30
DJ	4R7	4.7	±30	1kHz	80	1.90	1.20
DK	5R6	5.6	±30	1kHz	86	1.70	1.15
DL	6R8	6.8	±30	1kHz	97	1.50	1.05
DM	8R2	8.2	±30	1kHz	137	1.40	0.90
EA	100	10	±20	1kHz	147	1.30	0.82
EB	120	12	±20	1kHz	181	1.10	0.71
EC	150	15	±20	1kHz	244	0.96	0.59
ED	180	18	±20	1kHz	271	0.93	0.55
EE	220	22	±20	1kHz	305	0.80	0.50
EF	270	27	±20	1kHz	375	0.73	0.44
EG	330	33	±20	1kHz	510	0.65	0.42
EH	390	39	±20	1kHz	550	0.61	0.38
EJ	470	47	±20	1kHz	635	0.57	0.35
EK	560	56	±20	1kHz	740	0.51	0.32
EL	680	68	±20	1kHz	1,110	0.46	0.28
EM	820	82	±20	1kHz	1,230	0.43	0.26
FA	101	100	±20	1kHz	1,345	0.41	0.24
FB	121	120	±20	1kHz	1,550	0.37	0.22
FC	151	150	±20	1kHz	2,100	0.31	0.19

• Any products mentioned in this catalog are subject to any modification in their appearance and others for improvements without prior notification.  
 • The details listed here are not a guarantee of the individual products at the time of ordering. When using the products, you will be asked to check their specifications.

## DATA LIST (C4-K3L Series)

C4-K3L (Height : 3mm max.)

Item	Stamp	Inductance			DCR (mΩ) typ.	DC Current (A)	
		(μH)	Tolerance (%)	Test Freq. (kHz)		Inductance -10% typ.	Temp. Δ25K typ.
DA	1R0	1.0	±30	1kHz	12	1.95	-
DC	1R5	1.5	±30	1kHz	15	1.80	-
DE	2R2	2.2	±30	1kHz	18	1.60	-
DG	3R3	3.3	±30	1kHz	21	1.25	-
DH	3R9	3.9	±30	1kHz	23	1.10	-
DJ	4R7	4.7	±30	1kHz	25	1.10	-
DK	5R6	5.6	±30	1kHz	27	0.90	-
DL	6R8	6.8	±30	1kHz	33	0.80	-
DM	8R2	8.2	±30	1kHz	38	0.75	-
EA	100	10	±30	1kHz	47	0.70	-
EB	120	12	±20	1kHz	54	0.65	-
EC	150	15	±20	1kHz	65	0.60	-
ED	180	18	±20	1kHz	95	0.50	-
EE	220	22	±20	1kHz	111	0.45	-
EF	270	27	±20	1kHz	122	0.45	-
EG	330	33	±20	1kHz	135	0.40	-
EH	390	39	±20	1kHz	180	0.35	-
EJ	470	47	±20	1kHz	196	0.30	-
EK	560	56	±20	1kHz	221	0.30	-
EL	680	68	±20	1kHz	258	0.30	-
EM	820	82	±20	1kHz	289	0.25	-
FA	101	100	±20	1kHz	381	0.20	-
FB	121	120	±20	1kHz	437	0.20	-
FC	151	150	±20	1kHz	485	0.20	-

## DATA LIST (C4-K3LA Series)

C4-K3LA (Height : 3mm max.)

Item	Stamp	Inductance			DCR (mΩ) typ.	DC Current (A)	
		(μH)	Tolerance (%)	Test Freq. (kHz)		Inductance -10% typ.	Temp. Δ25K typ.
DA	1R0	1.0	±30	1kHz	13	3.00	4.00
DC	1R5	1.5	±30	1kHz	15	2.70	3.60
DD	1R8	1.8	±30	1kHz	19	2.40	3.20
DF	2R7	2.7	±30	1kHz	22	2.20	2.90
DG	3R3	3.3	±30	1kHz	24	2.15	2.80
DH	3R9	3.9	±30	1kHz	28	2.10	2.70
DK	5R6	5.6	±30	1kHz	47	1.75	2.50
DL	6R8	6.8	±30	1kHz	52	1.50	2.20
DM	8R2	8.2	±30	1kHz	57	1.30	2.00
EA	100	10	±20	1kHz	67	1.10	1.75
EB	120	12	±20	1kHz	72	1.00	1.60
EC	150	15	±20	1kHz	83	0.85	1.40
ED	180	18	±20	1kHz	127	0.80	1.30
EE	220	22	±20	1kHz	155	0.75	1.20
EF	270	27	±20	1kHz	177	0.70	1.10
EG	330	33	±20	1kHz	231	0.65	1.05
EH	390	39	±20	1kHz	252	0.60	0.90
EJ	470	47	±20	1kHz	281	0.50	0.80
EK	560	56	±20	1kHz	402	0.45	0.70
EL	680	68	±20	1kHz	449	0.42	0.60
EM	820	82	±20	1kHz	522	0.40	0.55
FA	101	100	±20	1kHz	754	0.38	0.50
FB	121	120	±20	1kHz	828	0.37	0.48
FC	151	150	±20	1kHz	976	0.36	0.44

• Any products mentioned in this catalog are subject to any modification in their appearance and others for improvements without prior notification.  
 • The details listed here are not a guarantee of the individual products at the time of ordering. When using the products, you will be asked to check their specifications.

## DATA LIST (C5-K1.8L Series)

C5-K1.8L (Height : 1.9mm max.)

Item	Stamp	Inductance			DCR (mΩ) typ.	DC Current (A)	
		(μH)	Tolerance (%)	Test Freq. (kHz)		Inductance -10% typ.	Temp. Δ25K typ.
DA	1R0	1.0	±30	1kHz	10	3.90	5.50
DB	1R2	1.2	±30	1kHz	13	3.10	4.30
DD	1R8	1.8	±30	1kHz	19	2.50	4.00
DF	2R7	2.7	±30	1kHz	23	2.20	3.20
DG	3R3	3.3	±30	1kHz	32	1.80	2.80
DJ	4R7	4.7	±30	1kHz	38	1.50	2.60
DK	5R6	5.6	±30	1kHz	43	1.40	2.55
DL	6R8	6.8	±30	1kHz	58	1.30	2.05
DM	8R2	8.2	±30	1kHz	64	1.27	2.00
EA	100	10	±20	1kHz	85	1.15	1.65
EB	120	12	±20	1kHz	94	1.10	1.60
EC	150	15	±20	1kHz	112	0.90	1.50
ED	180	18	±20	1kHz	138	0.70	1.30
EE	220	22	±20	1kHz	163	0.68	1.15
EF	270	27	±20	1kHz	186	0.65	1.10
EG	330	33	±20	1kHz	243	0.55	1.00
EH	390	39	±20	1kHz	275	0.50	0.90
EJ	470	47	±20	1kHz	410	0.45	0.70
EK	560	56	±20	1kHz	432	0.43	0.65
EL	680	68	±20	1kHz	476	0.36	0.60
EM	820	82	±20	1kHz	716	0.34	0.50
FA	101	100	±20	1kHz	805	0.31	0.46
FB	121	120	±20	1kHz	940	0.30	0.44
FC	151	150	±20	1kHz	1,083	0.28	0.40

## DATA LIST (C5-K1.8LA Series)

C5-K1.8LA (Height : 1.8mm max.)

Item	Stamp	Inductance			DCR (mΩ) typ.	DC Current (A)	
		(μH)	Tolerance (%)	Test Freq. (kHz)		Inductance -10% typ.	Temp. Δ25K typ.
DB	1R2	1.2	±30	1kHz	17	3.10	3.37
DD	1R8	1.8	±30	1kHz	21	2.50	3.01
DF	2R7	2.7	±30	1kHz	30	2.23	2.60
DG	3R3	3.3	±30	1kHz	35	2.08	2.30
DH	3R9	3.9	±30	1kHz	51	1.92	2.00
DJ	4R7	4.7	±30	1kHz	57	1.70	1.86
DK	5R6	5.6	±30	1kHz	77	1.62	1.80
DL	6R8	6.8	±30	1kHz	85	1.54	1.75
DM	8R2	8.2	±30	1kHz	109	1.48	1.61
EA	100	10	±20	1kHz	118	1.40	1.50
EB	120	12	±20	1kHz	129	1.20	1.24
EC	150	15	±20	1kHz	165	0.97	1.03
ED	180	18	±20	1kHz	175	0.94	0.92
EE	220	22	±20	1kHz	226	0.90	0.83
EF	270	27	±20	1kHz	281	0.77	0.74
EG	330	33	±20	1kHz	382	0.64	0.63
EH	390	39	±20	1kHz	420	0.58	0.61
EJ	470	47	±20	1kHz	474	0.53	0.59
EK	560	56	±20	1kHz	581	0.49	0.54
EL	680	68	±20	1kHz	654	0.45	0.49
EM	820	82	±20	1kHz	836	0.40	0.44
FA	101	100	±20	1kHz	965	0.36	0.39
FB	121	120	±20	1kHz	1,280	0.33	0.35
FC	151	150	±20	1kHz	1,452	0.30	0.32

## DATA LIST (C5-K3LGA Series)

C5-K3LGA (Height : 3mm max.)

Item	Stamp	Inductance			DCR (mΩ) typ.	DC Current (A)	
		(μH)	Tolerance (%)	Test Freq. (kHz)		Inductance -30% typ.	Temp. Δ40K typ.
DB	1R2	1.2	±30	1kHz	17	5.00	4.00
DD	1R8	1.8	±30	1kHz	21	4.50	3.70
DE	2R2	2.2	±30	1kHz	25	4.00	3.50
DG	3R3	3.3	±30	1kHz	29	3.60	3.20
DJ	4R7	4.7	±30	1kHz	33	3.20	2.80
DK	5R6	5.6	±30	1kHz	46	2.90	2.50
DL	6R8	6.8	±30	1kHz	52	2.50	2.40
EA	100	10	±30	1kHz	62	2.10	2.00
EB	120	12	±30	1kHz	77	2.00	1.90
EC	150	15	±30	1kHz	84	1.80	1.80
EE	220	22	±20	1kHz	183	1.40	1.30
EG	330	33	±20	1kHz	224	1.20	1.10
EJ	470	47	±20	1kHz	270	1.00	1.00
EL	680	68	±20	1kHz	470	0.80	0.70
FA	101	100	±20	1kHz	590	0.65	0.55

## DATA LIST (C6-K1.8L Series)

C6-K1.8L (Height : 2.0mm max.)

Item	Stamp	Inductance			DCR (mΩ) typ.	DC Current (A)	
		(μH)	Tolerance (%)	Test Freq. (kHz)		Inductance -30% typ.	Temp. Δ40K typ.
DA	1R0	1.0	±30	1kHz	13	5.10	5.70
DC	1R5	1.5	±30	1kHz	24	4.60	3.60
DE	2R2	2.2	±30	1kHz	38	3.40	2.60
DG	3R3	3.3	±30	1kHz	46	3.10	2.30
DH	3R9	3.9	±30	1kHz	43	2.80	2.20
DJ	4R7	4.7	±30	1kHz	64	2.40	2.10
DK	5R6	5.6	±30	1kHz	72	2.30	2.00
DL	6R8	6.8	±30	1kHz	82	2.20	1.80
EA	100	10	±20	1kHz	140	1.70	1.20
EC	150	15	±20	1kHz	177	1.40	1.10
EE	220	22	±20	1kHz	300	1.20	1.00
EG	330	33	±20	1kHz	444	1.00	0.70

## DATA LIST (C6-K3LG Series)

C6-K3LG (Height : 3.2mm max.)

Item	Stamp	Inductance			DCR (mΩ) typ.	DC Current (A)	
		(μH)	Tolerance (%)	Test Freq. (kHz)		Inductance -30% typ.	Temp. Δ40K typ.
DA	1R0	1.0	±30	1kHz	8	6.30	6.30
DD	1R8	1.8	±30	1kHz	10	5.30	5.20
DF	2R5	2.5	±30	1kHz	13	4.80	4.80
DG	3R3	3.3	±30	1kHz	16	4.00	4.50
DJ	4R5	4.5	±30	1kHz	20	3.50	3.75
DK	5R6	5.6	±30	1kHz	24	3.10	3.60
DL	6R8	6.8	±30	1kHz	27	2.80	3.30
DM	8R5	8.5	±30	1kHz	37	2.50	3.00
EA	100	10	±30	1kHz	41	2.30	2.70
EB	120	12	±30	1kHz	45	2.10	2.60
EC	160	16	±30	1kHz	70	1.90	2.35
ED	180	18	±20	1kHz	75	1.75	2.25
EE	220	22	±20	1kHz	89	1.60	2.10
EF	270	27	±20	1kHz	92	1.50	2.00
EG	330	33	±20	1kHz	123	1.25	1.60
EH	390	39	±20	1kHz	157	1.20	1.40
EJ	470	47	±20	1kHz	173	1.10	1.30
EK	560	56	±20	1kHz	213	1.00	1.25
EL	680	68	±20	1kHz	235	0.90	1.15
EM	820	82	±20	1kHz	350	0.80	0.95
FA	101	100	±20	1kHz	387	0.70	0.90
FJ	471	470	±20	1kHz	2,200	0.32	0.33
FM	821	820	±20	1kHz	2,900	0.24	0.30
GA	102	1,000	±20	1kHz	3,800	0.21	0.24

## DATA LIST (C6-K5LGA Series)

C6-K5LGA (Height : 5mm max.)

Item	Stamp	Inductance			DCR (mΩ) typ.	DC Current (A)	
		(μH)	Tolerance (%)	Test Freq. (kHz)		Inductance -30% typ.	Temp. Δ40K typ.
DB	1R2	1.2	±30	1kHz	10	9.00	6.50
DD	1R8	1.8	±30	1kHz	12	8.00	6.00
DE	2R4	2.4	±30	1kHz	14	7.00	5.80
DG	3R3	3.3	±30	1kHz	18	6.00	5.40
DH	4R3	4.3	±30	1kHz	22	5.20	4.30
DJ	5R1	5.1	±30	1kHz	25	4.80	4.00
DL	6R2	6.2	±30	1kHz	30	4.50	3.80
DM	8R2	8.2	±30	1kHz	32	4.20	3.40
EA	100	10	±30	1kHz	35	3.60	3.20
EC	150	15	±30	1kHz	60	2.80	2.40
EE	220	22	±20	1kHz	90	2.40	2.10
EG	330	33	±20	1kHz	130	2.00	1.80
EJ	470	47	±20	1kHz	155	1.80	1.60
EK	560	56	±20	1kHz	165	1.60	1.50
EL	680	68	±20	1kHz	225	1.40	1.30
EM	820	82	±20	1kHz	280	1.20	1.10
FA	101	100	±20	1kHz	390	1.10	0.90
FJ	471	470	±20	1kHz	1,400	0.53	0.40
FM	821	820	±20	1kHz	3,400	0.40	0.26
GA	102	1,000	±20	1kHz	3,700	0.37	0.25
GE	222	2,200	±20	1kHz	8,600	0.25	0.16
GG	332	3,300	±20	1kHz	10,700	0.23	0.14

## DATA LIST (C6-K5RA Series)

C6-K5RA (Height : 5mm max.)

Item	Stamp	Inductance			DCR (mΩ) typ.	DC Current (A)	
		(μH)	Tolerance (%)	Test Freq. (kHz)		Inductance -30% typ.	Temp. Δ40K typ.
DC	1R5	1.5	±30	1kHz	14	8.50	5.80
DE	2R2	2.2	±30	1kHz	17	6.30	5.30
DF	2R7	2.7	±30	1kHz	20	6.00	5.10
DH	3R6	3.6	±30	1kHz	24	5.60	4.70
DJ	4R7	4.7	±30	1kHz	28	4.70	4.00
DK	5R6	5.6	±30	1kHz	31	4.40	3.80
DL	6R8	6.8	±30	1kHz	34	4.30	3.50
DM	8R2	8.2	±30	1kHz	37	3.90	3.40
EA	100	10	±30	1kHz	40	3.50	3.30
EC	150	15	±30	1kHz	60	2.80	2.40
EE	220	22	±20	1kHz	90	2.40	2.10
EG	330	33	±20	1kHz	130	2.00	1.80
EJ	470	47	±20	1kHz	160	1.70	1.60
EK	560	56	±20	1kHz	165	1.60	1.50
EL	680	68	±20	1kHz	225	1.40	1.30
EM	820	82	±20	1kHz	280	1.30	1.10
FA	101	100	±20	1kHz	390	1.10	1.00

## DATA LIST (C8-K4L Series)

C8-K4L (Height : 4mm max.)

Item	Stamp	Inductance			DCR (mΩ) typ.	DC Current (A)	
		(μH)	Tolerance (%)	Test Freq. (kHz)		Inductance -10% typ.	Temp. Δ25K typ.
DA	1R0	1.0	±30	1kHz	10	7.00	-
DC	1R5	1.5	±30	1kHz	12	6.50	-
DE	2R2	2.2	±30	1kHz	14	5.60	-
DF	2R7	2.7	±30	1kHz	16	5.20	-
DH	3R9	3.9	±30	1kHz	18	4.30	-
DJ	4R7	4.7	±30	1kHz	21	4.20	-
DK	5R6	5.6	±30	1kHz	23	4.10	-
DL	6R8	6.8	±30	1kHz	28	3.50	-
DM	8R2	8.2	±30	1kHz	33	3.10	-
EA	100	10	±20	1kHz	38	2.70	-
EB	120	12	±20	1kHz	44	2.60	-
EC	150	15	±20	1kHz	50	2.30	-
ED	180	18	±20	1kHz	54	2.20	-
EE	220	22	±20	1kHz	78	1.90	-
EF	270	27	±20	1kHz	89	1.50	-
EG	330	33	±20	1kHz	111	1.40	-
EH	390	39	±20	1kHz	121	1.30	-
EJ	470	47	±20	1kHz	142	1.20	-
EK	560	56	±20	1kHz	155	1.10	-
EL	680	68	±20	1kHz	200	1.05	-
EM	820	82	±20	1kHz	250	1.00	-
FA	101	100	±20	1kHz	310	0.95	-
FB	121	120	±20	1kHz	341	0.82	-
FC	151	150	±20	1kHz	421	0.73	-

• Any products mentioned in this catalog are subject to any modification in their appearance and others for improvements without prior notification.  
 • The details listed here are not a guarantee of the individual products at the time of ordering. When using the products, you will be asked to check their specifications.

## DATA LIST (C8-K5L Series)

C8-K5L (Height : 5mm max.)

Item	Stamp	Inductance			DCR (mΩ) typ.	DC Current (A)	
		(μH)	Tolerance (%)	Test Freq. (kHz)		Inductance -10% typ.	Temp. Δ25K typ.
DA	1R0	1.0	±30	1kHz	10	7.00	-
DC	1R5	1.5	±30	1kHz	12	6.50	-
DE	2R2	2.2	±30	1kHz	14	5.60	-
DF	2R7	2.7	±30	1kHz	16	5.20	-
DH	3R9	3.9	±30	1kHz	18	4.30	-
DJ	4R7	4.7	±30	1kHz	20	4.20	-
DK	5R6	5.6	±30	1kHz	22	4.10	-
DL	6R8	6.8	±30	1kHz	26	3.50	-
DM	8R2	8.2	±30	1kHz	28	3.10	-
EA	100	10	±20	1kHz	31	2.70	-
EB	120	12	±20	1kHz	34	2.60	-
EC	150	15	±20	1kHz	40	2.30	-
ED	180	18	±20	1kHz	46	2.20	-
EE	220	22	±20	1kHz	53	1.90	-
EF	270	27	±20	1kHz	64	1.50	-
EG	330	33	±20	1kHz	74	1.40	-
EH	390	39	±20	1kHz	86	1.30	-
EJ	470	47	±20	1kHz	100	1.20	-
EK	560	56	±20	1kHz	128	1.10	-
EL	680	68	±20	1kHz	150	1.05	-
EM	820	82	±20	1kHz	174	1.00	-
FA	101	100	±20	1kHz	209	0.95	-
FB	121	120	±20	1kHz	260	0.82	-
FC	151	150	±20	1kHz	348	0.73	-
FJ	471	470	±20	1kHz	1,300	0.40	0.38
FM	821	820	±20	1kHz	2,300	0.26	0.28
GA	102	1,000	±20	1kHz	2,600	0.25	0.26
GE	222	2,200	±20	1kHz	5,600	0.18	0.22
GG	332	3,300	±20	1kHz	10,200	0.15	0.14
GJ	472	4,700	±20	1kHz	12,500	0.13	0.13
GK	562	5,600	±20	1kHz	14,000	0.11	0.11

• Any products mentioned in this catalog are subject to any modification in their appearance and others for improvements without prior notification.  
 • The details listed here are not a guarantee of the individual products at the time of ordering. When using the products, you will be asked to check their specifications.

## DATA LIST (C8-K5LA Series)

C8-K5LA (Height : 5mm max.)

Item	Stamp	Inductance			DCR (mΩ) typ.	DC Current (A)	
		(μH)	Tolerance (%)	Test Freq. (kHz)		Inductance -30% typ.	Temp. Δ40K typ.
DB	1R2	1.2	±30	1kHz	11	10.3	7.00
DD	1R8	1.8	±30	1kHz	12	9.00	6.20
DE	2R2	2.2	±30	1kHz	16	7.50	5.80
DG	3R3	3.3	±30	1kHz	19	6.80	5.00
DH	3R9	3.9	±30	1kHz	25	5.70	4.30
DJ	4R7	4.7	±30	1kHz	27	5.50	4.00
DK	5R6	5.6	±30	1kHz	35	4.80	3.50
DL	6R8	6.8	±30	1kHz	38	4.50	3.30
DM	8R2	8.2	±30	1kHz	42	4.20	3.10
EA	100	10	±20	1kHz	55	3.60	2.80
EB	120	12	±20	1kHz	60	3.40	2.70
EC	150	15	±20	1kHz	65	3.20	2.60
ED	180	18	±20	1kHz	77	2.80	2.30
EE	220	22	±20	1kHz	88	2.60	2.20
EF	270	27	±20	1kHz	112	2.40	1.90
EG	330	33	±20	1kHz	124	2.20	1.70
EH	390	39	±20	1kHz	134	2.10	1.60
EJ	470	47	±20	1kHz	160	1.80	1.50
EK	560	56	±20	1kHz	226	1.60	1.30
EL	680	68	±20	1kHz	250	1.50	1.10
EM	820	82	±20	1kHz	317	1.40	1.05
FA	101	100	±20	1kHz	352	1.30	0.95
FB	121	120	±20	1kHz	392	1.20	0.90
FC	151	150	±20	1kHz	438	1.10	0.85

## DATA LIST (C10-K4L Series)

C10-K4L (Height : 4mm max.)

Item	Stamp	Inductance			DCR (mΩ) typ.	DC Current (A)	
		(μH)	Tolerance (%)	Test Freq. (kHz)		Inductance -10% typ.	Temp. Δ25K typ.
DA	1R0	1.0	±30	1kHz	11	7.10	-
DC	1R5	1.5	±30	1kHz	13	5.40	-
DE	2R2	2.2	±30	1kHz	16	5.30	-
DG	3R3	3.3	±30	1kHz	18	4.90	-
DJ	4R7	4.7	±30	1kHz	21	4.60	-
DK	5R6	5.6	±30	1kHz	23	4.10	-
DL	6R8	6.8	±30	1kHz	27	3.50	-
DM	8R2	8.2	±30	1kHz	30	3.30	-
EA	100	10	±30	1kHz	33	3.00	-
EB	120	12	±30	1kHz	36	2.90	-
EC	150	15	±30	1kHz	39	2.60	-
ED	180	18	±30	1kHz	43	2.40	-
EE	220	22	±30	1kHz	57	2.10	-
EF	270	27	±20	1kHz	91	2.00	-
EG	330	33	±20	1kHz	103	1.80	-
EH	390	39	±20	1kHz	116	1.70	-
EJ	470	47	±20	1kHz	128	1.50	-
EK	560	56	±20	1kHz	141	1.40	-
EL	680	68	±20	1kHz	161	1.20	-
EM	820	82	±20	1kHz	213	1.10	-
FA	101	100	±20	1kHz	255	1.00	-
FB	121	120	±20	1kHz	274	0.95	-
FC	151	150	±20	1kHz	313	0.85	-
FJ	471	470	±20	1kHz	1,400	0.45	0.35
FM	821	820	±20	1kHz	2,500	0.34	0.28
GA	102	1,000	±20	1kHz	3,700	0.31	0.22
GE	222	2,200	±20	1kHz	6,900	0.21	0.16
GG	332	3,300	±20	1kHz	10,700	0.17	0.14
GJ	472	4,700	±20	1kHz	12,700	0.15	0.13

## DATA LIST (C12-K4.5L Series)

C12-K4.5L (Height : 4.5mm max.)

Item	Stamp	Inductance			DCR (mΩ) typ.	DC Current (A)	
		(μH)	Tolerance (%)	Test Freq. (kHz)		Inductance -10% typ.	Temp. Δ25K typ.
DA	1R0	1.0	±30	1kHz	7	7.10	-
DC	1R5	1.5	±30	1kHz	9	6.80	-
DE	2R2	2.2	±30	1kHz	12	6.60	-
DG	3R3	3.3	±30	1kHz	15	6.40	-
DJ	4R7	4.7	±30	1kHz	18	6.20	-
DL	6R8	6.8	±30	1kHz	21	6.00	-
DM	8R2	8.2	±30	1kHz	23	5.50	-
EA	100	10	±30	1kHz	26	5.20	-
EB	120	12	±30	1kHz	40	4.00	-
EC	150	15	±30	1kHz	45	3.90	-
ED	180	18	±30	1kHz	54	3.80	-
EE	220	22	±30	1kHz	58	3.20	-
EF	270	27	±30	1kHz	71	2.80	-
EG	330	33	±20	1kHz	102	2.60	-
EH	390	39	±20	1kHz	109	2.40	-
EJ	470	47	±20	1kHz	148	2.20	-
EK	560	56	±20	1kHz	163	1.90	-
EL	680	68	±20	1kHz	211	1.80	-
EM	820	82	±20	1kHz	228	1.70	-
FA	101	100	±20	1kHz	256	1.50	-
FB	121	120	±20	1kHz	298	1.30	-
FC	151	150	±20	1kHz	430	1.20	-

**DATA LIST (C12-K7.5L Series)**

C12-K7.5L (Height : 7.5mm max.)

Item	Stamp	Inductance			DCR (mΩ) typ.	DC Current (A)	
		(μH)	Tolerance (%)	Test Freq. (kHz)		Inductance -30% typ.	Temp. Δ40K typ.
DA	1R0	1.0	±30	1kHz	6	23.5	12.0
DC	1R5	1.5	±30	1kHz	7	17.1	10.0
DF	2R7	2.7	±30	1kHz	9	15.5	9.00
DH	3R9	3.9	±30	1kHz	10	13.2	8.20
DJ	4R7	4.7	±30	1kHz	12	11.3	7.50
DL	6R8	6.8	±30	1kHz	13	10.1	6.80
DM	8R2	8.2	±30	1kHz	15	8.55	6.30
EA	100	10	±20	1kHz	18	7.55	5.80
EB	120	12	±20	1kHz	20	7.10	5.60
EC	150	15	±20	1kHz	21	6.50	5.40
ED	180	18	±20	1kHz	23	6.15	5.20
EE	220	22	±20	1kHz	26	5.75	5.00
EF	270	27	±20	1kHz	33	4.65	4.20
EG	330	33	±20	1kHz	41	4.50	3.80
EH	390	39	±20	1kHz	43	4.25	3.60
EJ	470	47	±20	1kHz	57	3.90	3.30
EK	560	56	±20	1kHz	62	3.55	3.10
EL	680	68	±20	1kHz	68	3.20	2.90
EM	820	82	±20	1kHz	81	2.80	2.80
FA	101	100	±20	1kHz	91	2.55	2.60
FB	121	120	±20	1kHz	119	2.40	2.40
FC	151	150	±20	1kHz	136	2.20	2.20
FJ	471	470	±20	1kHz	600	1.00	0.98
FM	821	820	±20	1kHz	900	0.77	0.75
GA	102	1,000	±20	1kHz	1,000	0.68	0.69
GE	222	2,200	±20	1kHz	2,700	0.44	0.40
GG	332	3,300	±20	1kHz	3,700	0.37	0.34
GJ	472	4,700	±20	1kHz	5,000	0.33	0.28
GK	562	5,600	±20	1kHz	5,500	0.28	0.27

• Any products mentioned in this catalog are subject to any modification in their appearance and others for improvements without prior notification.  
 • The details listed here are not a guarantee of the individual products at the time of ordering. When using the products, you will be asked to check their specifications.

## DATA LIST (C13-K4.5L Series)

C13-K4.5L (Height : 4.5mm max.)

Item	Stamp	Inductance			DCR (mΩ) typ.	DC Current (A)	
		(μH)	Tolerance (%)	Test Freq. (kHz)		Inductance -10% typ.	Temp. Δ25K typ.
DA	1R0	1.0	±30	1kHz	8	11.0	-
DC	1R5	1.5	±30	1kHz	10	9.21	-
DF	2R7	2.7	±30	1kHz	13	8.23	-
DH	3R9	3.9	±30	1kHz	18	7.08	-
DJ	4R7	4.7	±30	1kHz	22	6.36	-
DL	6R8	6.8	±30	1kHz	25	5.54	-
DM	8R2	8.2	±30	1kHz	28	5.07	-
EA	100	10	±30	1kHz	32	4.61	-
EB	120	12	±30	1kHz	36	4.25	-
EC	150	15	±30	1kHz	39	3.95	-
ED	180	18	±30	1kHz	43	3.68	-
EE	220	22	±30	1kHz	51	3.23	-
EF	270	27	±30	1kHz	59	3.00	-
EG	330	33	±30	1kHz	68	2.67	-
EH	390	39	±20	1kHz	151	2.33	-
EJ	470	47	±20	1kHz	171	2.10	-
EK	560	56	±20	1kHz	187	1.99	-
EL	680	68	±20	1kHz	215	1.80	-
EM	820	82	±20	1kHz	235	1.71	-
FA	101	100	±20	1kHz	265	1.57	-
FB	121	120	±20	1kHz	296	1.44	-
FC	151	150	±20	1kHz	339	1.33	-

## DIMENSIONS

### C4-K Series

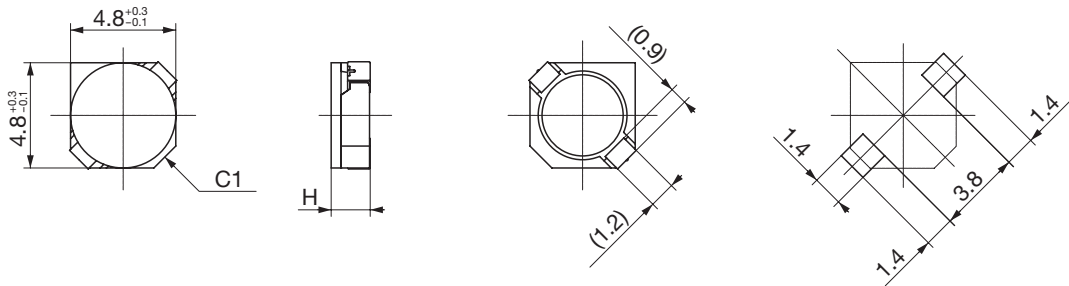

### C5-K Series

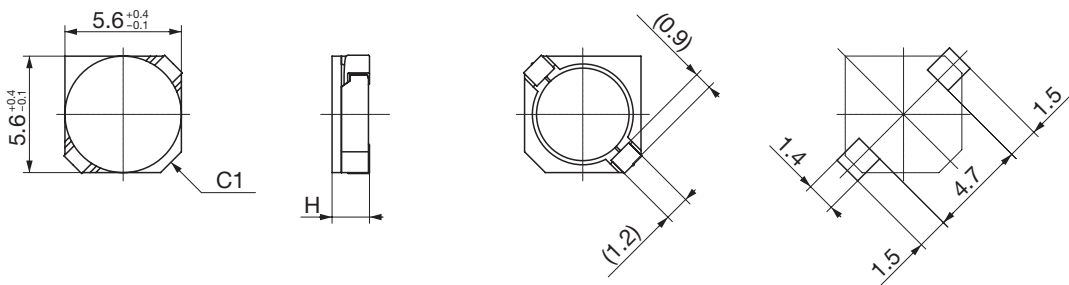

### C6-K Series

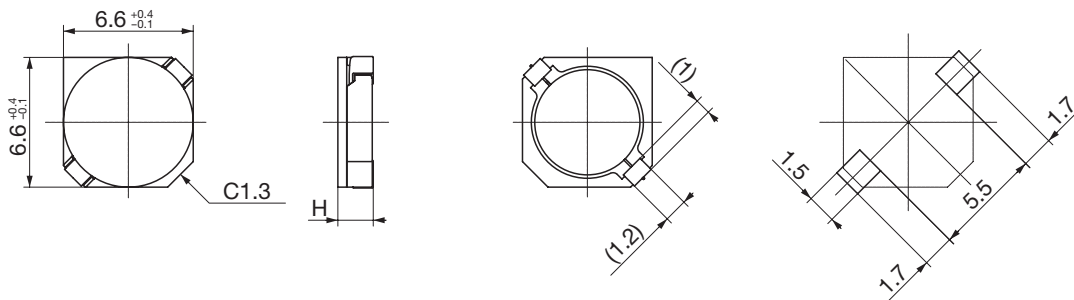

### C6-K5RA

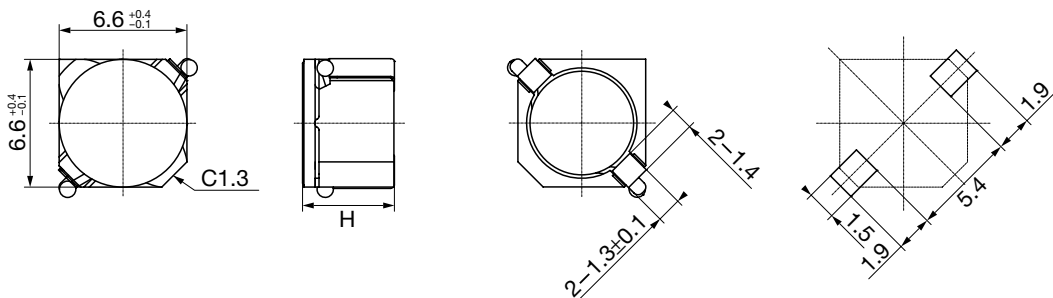

Recommended land patterns

Unit : mm

C8-K Series

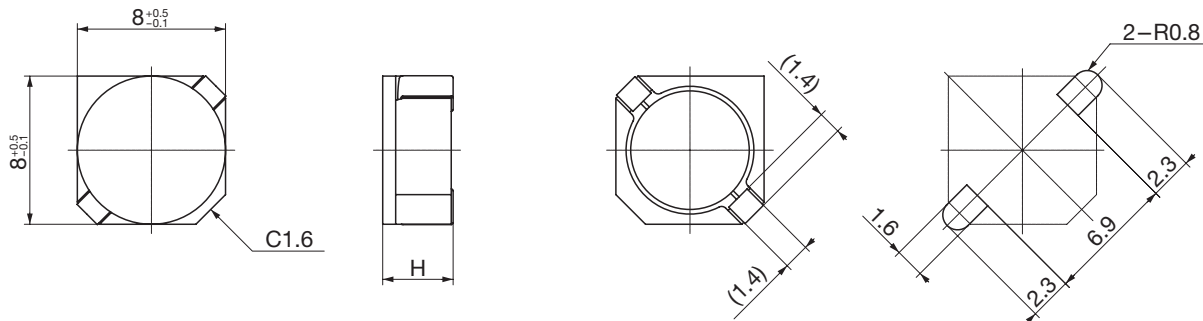

C10-K Series

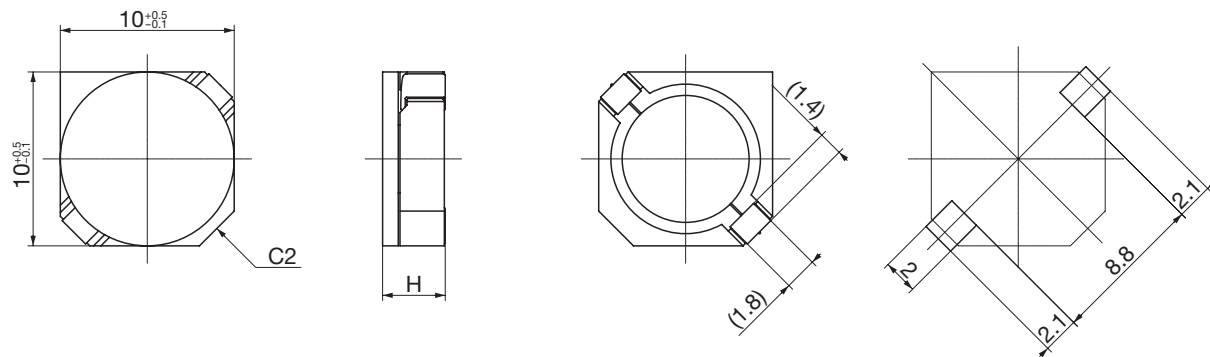

C12-K Series

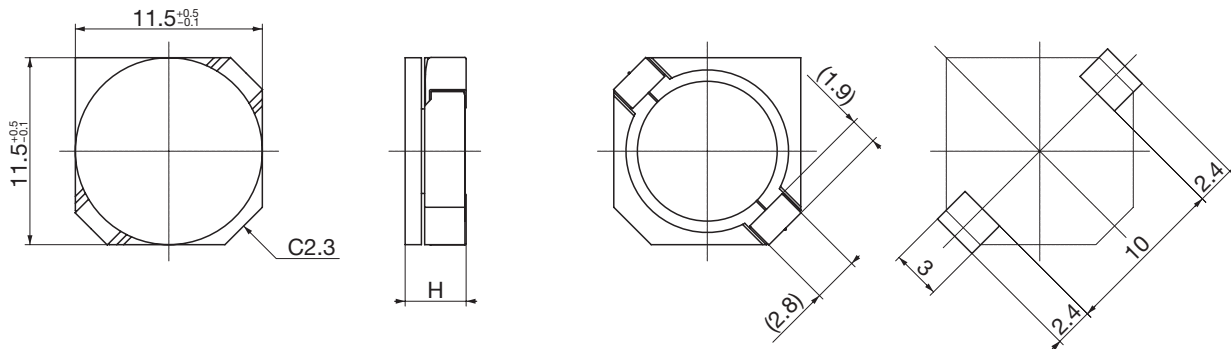

C13-K Series

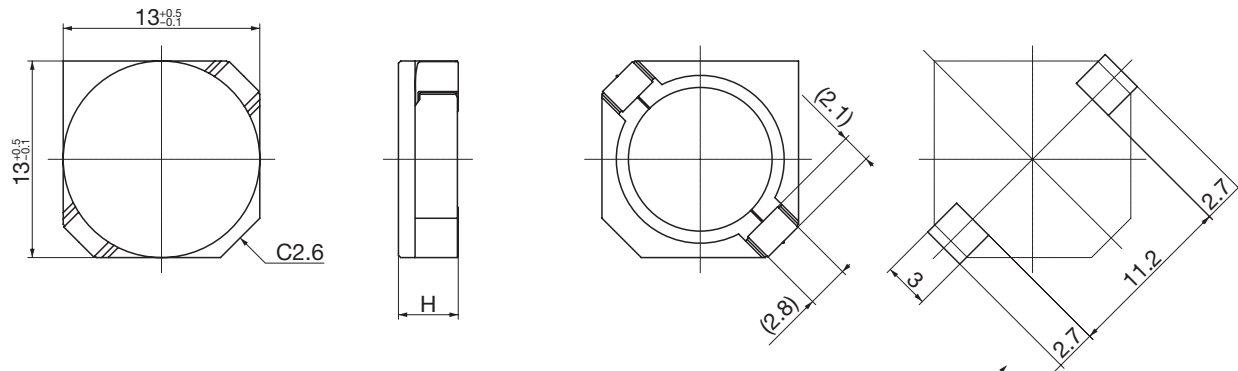

Recommended land patterns

Unit : mm

• Any products mentioned in this catalog are subject to any modification in their appearance and others for improvements without prior notification.  
 • The details listed here are not a guarantee of the individual products at the time of ordering. When using the products, you will be asked to check their specifications.