

Temperature Sensor for I²C BUS

Monolithic IC MM3285

Outline

This IC is an I²C BUS compatible digital temperature sensor IC incorporating a temperature sensor and sigma-delta AD converter. It provides low current consumption and I²C BUS compatible interface, which makes it ideal for a wide range of applications.

Features

1. Low current consumption (75μA typ.)
2. Shutdown mode minimizing current consumption
3. I²C BUS compatible interface
4. Up to 4 ICs can be built into a bus
5. Temperature data: 9 bit resolution with a LSB equal to 0.5°C
6. Fast update of time (2ms typ.)

Package

SOT-26A

Applications

1. LCD TVs
2. PCs
3. PC servers/network servers
4. System temperature monitoring
5. OA equipment

Block Diagram

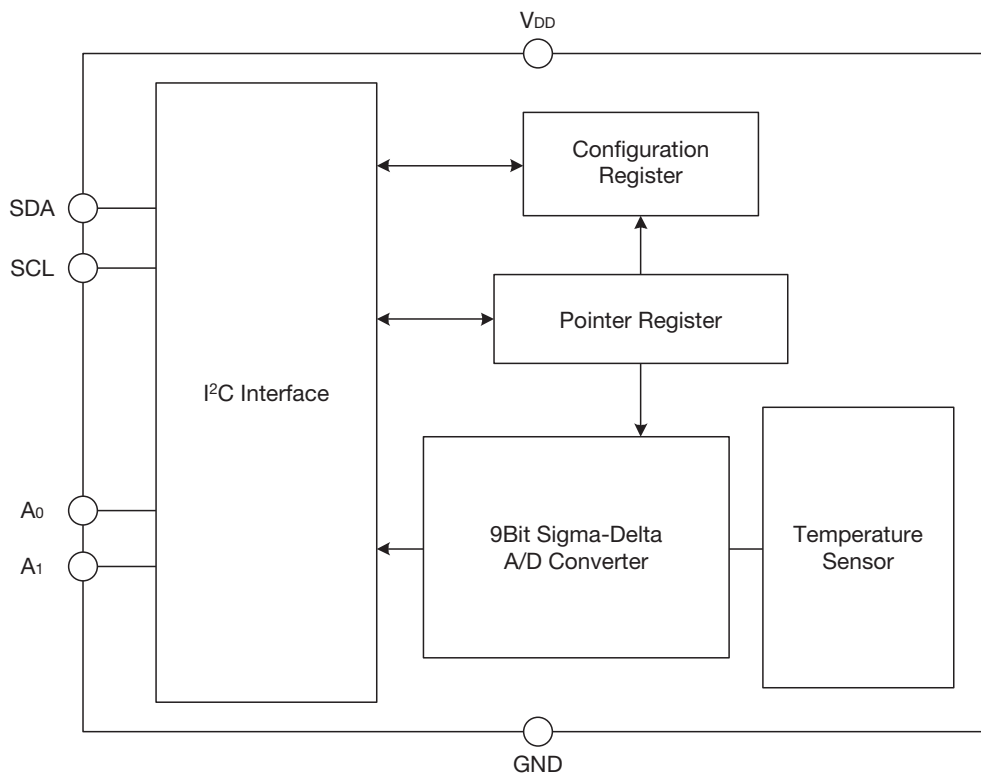

Pin Assignment

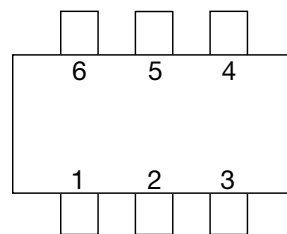

SOT-26A
(TOP VIEW)

1	SCL
2	GND
3	A ₁
4	V _{DD}
5	A ₀
6	SDA

Pin Description

Pin No.	Pin name	Functions	Internal equivalent circuit diagram
1	SCL	I ² C BUS Clock Input	
2	GND	Ground	
3	A ₁	Slave Address Set	
4	V _{DD}	Power Supply	
5	A ₀	Slave Address Set	
6	SDA	I ² C BUS Data I/O	

Absolute Maximum Ratings

Item	Symbol	Ratings	Units
Maximum supply voltage	V _{DDmax}	-0.3~+6.0	V
Maximum output voltage	V _{OUT}	-0.3~ (V _{DD} +0.3)	V
Allowable loss	P _d	300	mW
Storage temperature	T _{STG}	-65~+150	°C

Recommended Operating Conditions

Item	Symbol	Ratings	Units
Operating supply voltage	V _{DDOPR}	+3.0~+5.5	V
Operating temperature	T _{OPR}	-40~+125	°C

• Any products mentioned in this catalog are subject to any modification in their appearance and others for improvements without prior notification.
 • The details listed here are not a guarantee of the individual products at the time of ordering. When using the products, you will be asked to check their specifications.

Electrical Characteristics (Except where noted otherwise Ta=25°C, V_{DD}=3.3V)

Temperature-to-digital converter characteristics

Item	Symbol	Measurement conditions	Min.	Typ.	Max.	Units
Temperature detection accuracy (*1)	Ac	-25°C ≤ Ta ≤ 100°C			±2.0	°C
		-40°C ≤ Ta ≤ 125°C			±3.0	
Temperature data update time	T			2		ms
Supply current	I _{DD}	Normal operation		75	150	μA
		Shutdown mode		1		

Note1: *1 The specification values of temperature detection accuracy show values when supply voltage is 3.3V. Temperature data vary by +1°C/V (typ.) against supply voltage.

Logic electrical characteristics

Item	Symbol	Measurement conditions	Min.	Typ.	Max.	Units
Input voltage L	V _{IL}		-0.3		V _{DD} ×0.3	V
Input voltage H	V _{IH}		V _{DD} ×0.7		V _{DD} +0.3	
SDA low level output voltage	V _{OL}	SDA sink 3mA	0.0		0.4	V
High level input current	I _{IH}	SDA, SCL=3.3V	-10		10	μA
Low level input current	I _{IL}	SDA, SCL=0.4V	-10		10	μA
Clock frequency	f _{SCL}				400	kHz
Data transfer wait time	t _{BUF}		1.3			μs
SCL start hold time	t _{HD;STA}		0.6			μs
SCL low level hold time	t _{LOW}		1.3			μs
SCL high level hold time	t _{HIGH}		0.6			μs
Start condition setup time	t _{SU;STA}		0.6			μs
SDA data hold time	t _{HD;DAT}		0			μs
SDA data setup time	t _{SU;DAT}		100			ns
SDA,SCL rise time	t _R				300	ns
SDA,SCL fall time	t _F				300	ns
Stop condition setup time	t _{SU;STO}		0.6			μs

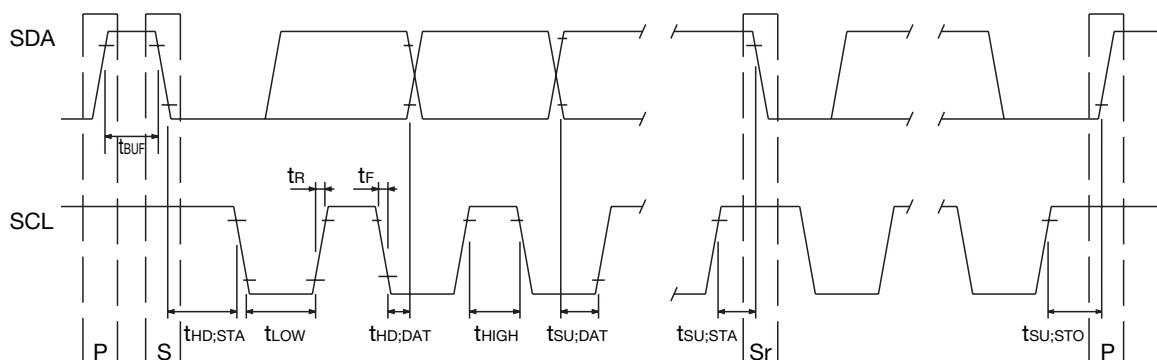

• Any products mentioned in this catalog are subject to any modification in their appearance and others for improvements without prior notification.
 • The details listed here are not a guarantee of the individual products at the time of ordering. When using the products, you will be asked to check their specifications.

Measuring Circuit

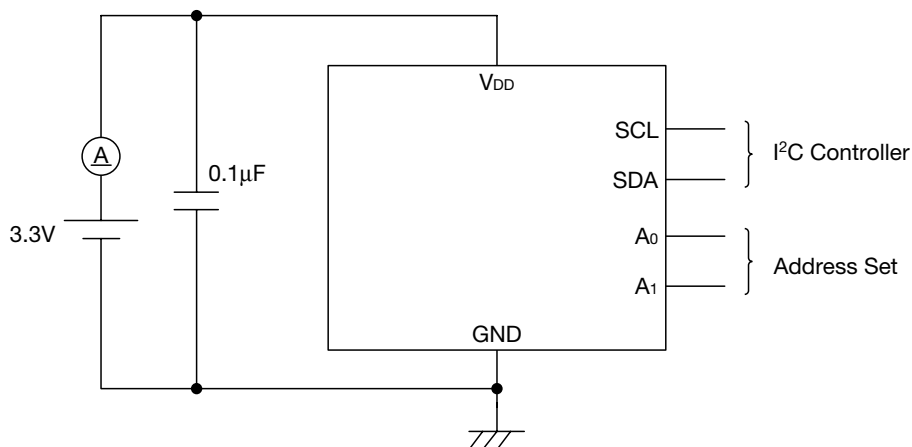

Application Circuit

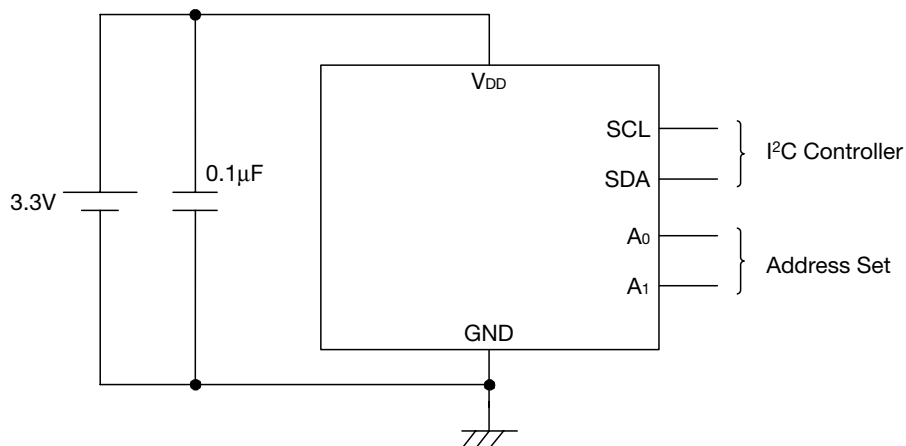

- Mitsumi shall not assume any liability for any accident or damage caused by use of this circuit.
- Mitsumi shall not assume any liability for any issues related to industrial property rights and/or other rights owned by third parties or shall not grant any license regarding use of this circuit.

I²C BUS

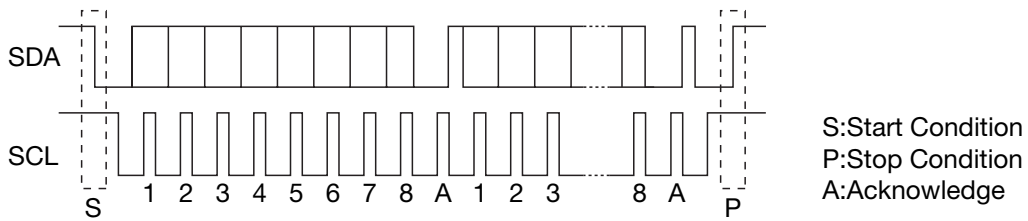

I²C BUS is inter-IC bus system to transfer data by 2 lines of SDA and SCL. Data transfer is performed by 1 byte, and acknowledgement is sent when each byte is complete. Data transfer takes place MSB first from a start condition.

There are a pointer register and two data registers selected by the pointer register in MM3285.

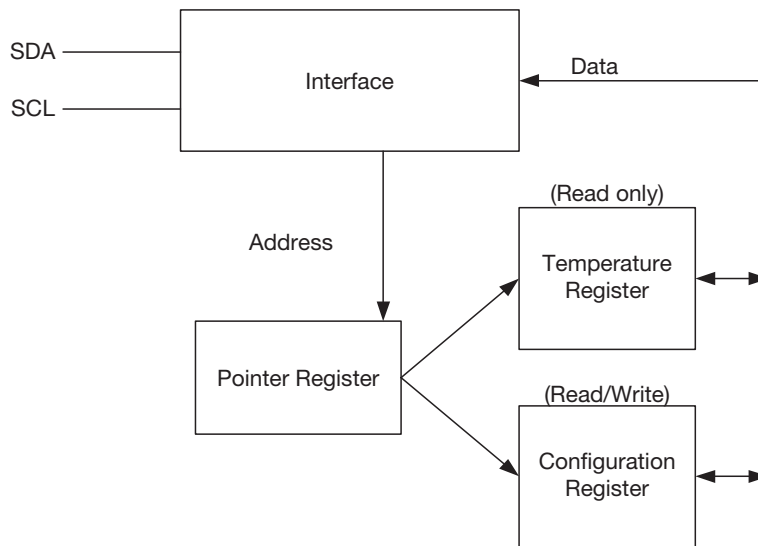

[I²C Data Format]

Read mode

The data format for read mode is set in the temperature and configuration register shown below.

S	Slave address								R/W	A	DATA1								A	DATA2								P
	1	0	0	1	0	A1	A0	1	D15		D14	D13	D12	D11	D10	D9	D8	D7		D6	D5	D4	D3	D2	D1	D0		
Address byte									Data byte								Data byte											

* If a selected register is the configuration register, data byte is 1 byte only.

Write mode

The data format for write mode is set in the configuration register shown below.

S	Slave address								R/W	A	Pointer Register								A	DATA1								P
	1	0	0	1	0	A1	A0	0	0		0	0	0	0	0	0	0	P0		0	0	0	0	0	0	0	0	
Address byte									Pointer byte								Data byte											

• Any products mentioned in this catalog are subject to any modification in their appearance and others for improvements without prior notification.
 • The details listed here are not a guarantee of the individual products at the time of ordering. When using the products, you will be asked to check their specifications.

[Register structure]

Pointer register

P7	P6	P5	P4	P3	P2	P1	P0
0	0	0	0	0	0	0	Register Select

1. P0: Register select

P0	Register
0	Temperature Register (Read only, Power-up default)
1	Configuration Register (Read/Write)

2. P1-P7: Must be kept to zero

Temperature register (Read only)

D15	D14	D13	D12	D11	D10	D9	D8	D7	D6	D5	D4	D3	D2	D1	D0
MSB	Bit7	Bit6	Bit5	Bit4	Bit3	Bit2	Bit1	LSB	X	X	X	X	X	X	X

1. D0-D6: Undefined

2. D7-D15: Temperature data.

* Temperature data format

Temperature data is represented by a 9-bit (8 bits plus a sign bit) and two complement words with an LSB equal to 0.5°C.

Temperature	Digital output	
	Binary code	Hex
±125°C	0 1111 1010	0FAh
±100°C	0 1100 1000	0C8h
±80°C	0 1010 0000	0A0h
±60°C	0 0111 1000	078h
±40°C	0 0101 0000	050h
±25°C	0 0011 0010	032h
±0.5°C	0 0000 0001	001h
0°C	0 0000 0000	000h
-0.5°C	1 1111 1111	1FFh
-10°C	1 1110 1100	1ECh
-25°C	1 1100 1110	1CEh
-40°C	1 1011 0000	1B0h

Configuration register (Read/Write)

D7	D6	D5	D4	D3	D2	D1	D0
0	0	0	0	0	0	0	Shutdown Mode Select

1. D0: Shutdown mode select

D0	Shutdown mode
0	Normal operation
1	Shutdown

* Shutdown mode

Current consumption during shutdown mode is 1µA typ., which achieves reduction in power consumption during standby mode.

5. D1-D7: Must be kept zero for normal operation.

* Power-up default is with all bits (D0 to D7) "0" (zero).

Characteristics

Ambient temperature - accuracy

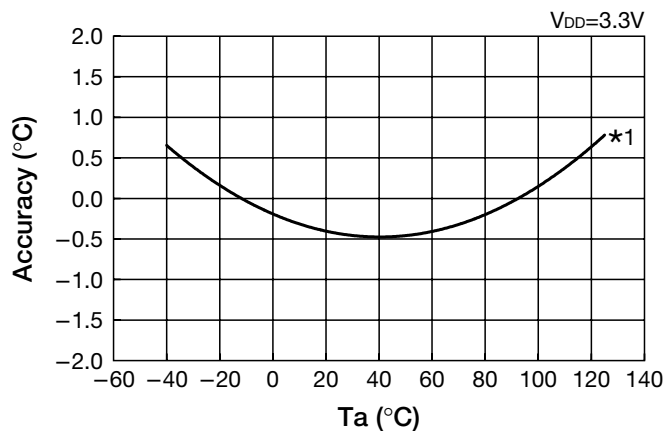

Note1: *1 The characteristic graph shows an approximate curved line.

Ambient temperature - supply current

