

Temperature Switch IC with Hysteresis

Monolithic IC MM3488

Outline

This IC is a temperature switch IC that changes the IC output level from Low to High when the temperature around the IC reaches the detection temperature. With the hysteresis function, IC output level returns to Low when the ambient temperature drops to the hysteresis temperature selected after detection. Detection temperature T_{DET} can be selected in 1.0°C steps between the range of 60 to 90°C with rank expansion, with detection temperature accuracy of $\pm 2.0^\circ\text{C}$.

Features

1. Low current consumption
2. Small package
3. High Temperature accuracy
4. Low power supply operation range
5. Comes with hysteresis function





Package

SSON-4B

Applications

1. Cellular phones
2. LCD TVs/panels
3. Game equipment
4. PCs
5. System thermal monitor
6. OA equipment

Model Name

M M 3 4 8 8     E

1 2 3 4

1		2	
Hysteresis Temperature (T _{HYS})		Detecting Temperature (T _{DET})	
A	T _{HYS} =5.0°C	60	T _{DET} =+60°C
B	T _{HYS} =10°C	∞	T _{DET} is 1.0°C steps
C	T _{HYS} =15°C	90	T _{DET} =+90°C

3		4	
Package		Packing Specifications	
R	SSON-4B	R	R HOUSING (Standard)
		L	L HOUSING

Block Diagram

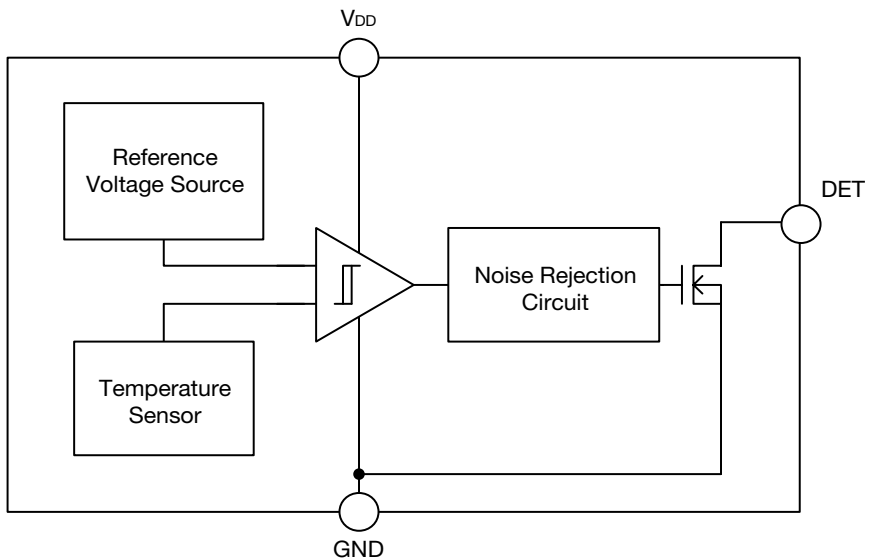

Pin Assignment

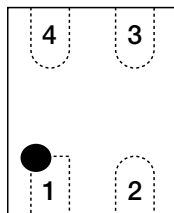

SSON-4B
(TOP VIEW)

1	DET
2	GND
3	NC
4	V _{DD}

• Any products mentioned in this catalog are subject to any modification in their appearance and others for improvements without prior notification.
 • The details listed here are not a guarantee of the individual products at the time of ordering. When using the products, you will be asked to check their specifications.

Pin Description

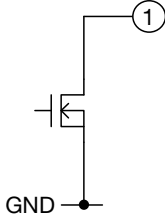
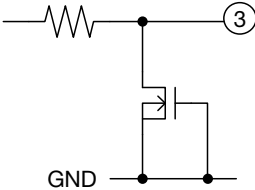
Pin No.	Pin Name	Function	Internal Equivalent Circuit
1	DET	Temp. Detect Output Pin	
2	GND	Ground pin	
3	NC (Note1)	NC (Testing pin)	
4	V _{DD}	Power supply pin	

Note1 : Testing pin is connected with the internal circuit for testing.

When resistance and capacity are connected with Testing pin, this product produce improper operating signals. Please set Testing pin to the open state.

Absolute Maximum Ratings

Item	Symbol	Ratings	Units
Maximum Supply Voltage	V _{DDmax}	-0.3~+6.0	V
Terminal Voltage	DET _{max}	-0.3~+6.0	V
Storage Temperature	T _{stg}	-55~+125	°C
Power Dissipation	P _d	150	mW

Recommended Operating Conditions

Item	Symbol	Ratings	Units
Operating Supply Voltage	V _{DDopr}	+1.6~+5.0	V
Operating Temperature	T _{opr}	-30~+105	°C

Electrical Characteristics (Except where noted otherwise Ta=25°C, VDD=1.8V)

Item	Symbol	Measurement conditions	Min.	Typ.	Max.	Units
Operating Supply Voltage	V _{DD}	T _{DET} =60~90°C	1.6	1.8	5.0	V
Detecting Temperature Accuracy (Note2)	T _{DETAC1}	V _{DD} =1.6~3.3V	-2.0	0	+2.0	°C
	T _{DETAC2}	V _{DD} =3.3~5.0V	-1.5	+0.5	+2.5	°C
Hysteresis Temperature (Note3)	T _{HYS}	T _{HYS} =5.0°C	2.5	5.0	7.5	°C
		T _{HYS} =10°C	7.0	10.0	13.0	°C
		T _{HYS} =15°C	10.5	15.0	19.5	°C
DET Sink Current	I _{DETL}	V _{DET} =0.4V, V _{DET} =Low Level	4.0	12.0		mA
DET Leak Current	I _{LEAK}	V _{DD} =5.0V, V _{DET} =High Level			0.1	μA
Supply Current	I _{DD}			1.5	3.5	μA
Noise Rejection Time	t _{noise}	Ta=+60~+90°C		250	500	μs
VDD Start-up Response	t _{vsr}	R _{PULL-UP} = 1MΩ		100	500	μs

Note2 : Detection temperature can be selected in 1.0°C steps (+60~+90°C)

Note3 : Hysteresis temperature can be selected in 5.0°C steps (5.0°C, 10°C, 15°C)

Timing Chart

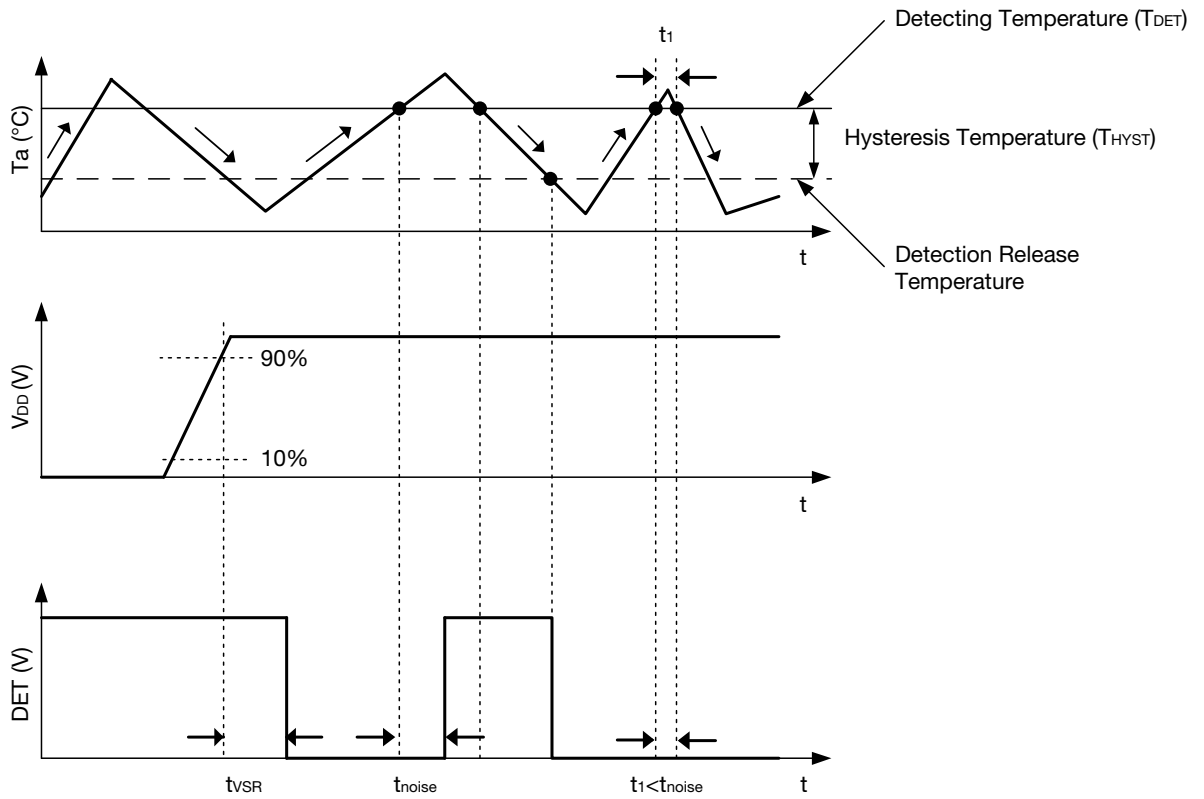

Application Circuit

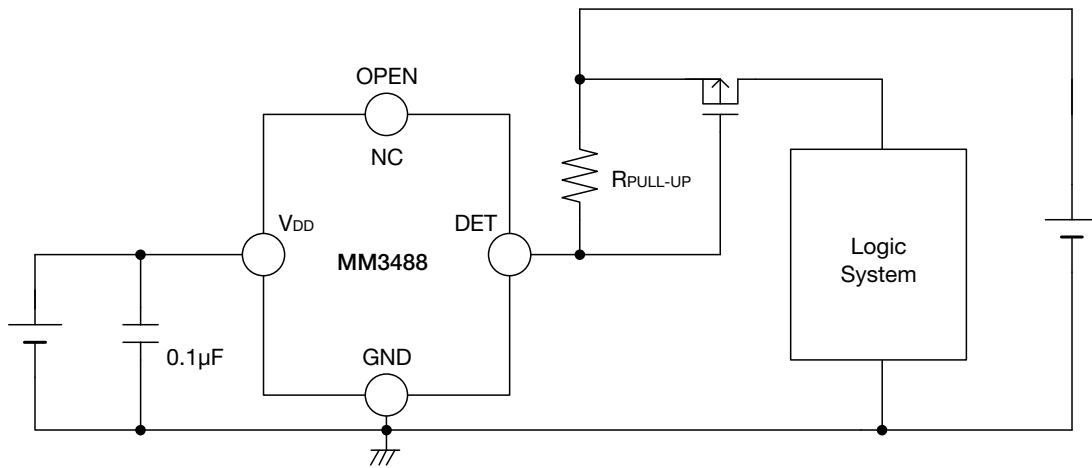

- We shall not be liable for any trouble or damage caused by using this circuit.
- In the event a problem which may affect industrial property or any other rights of us or a third party is encountered during the use of information described in these circuit, Mitsumi Electric Co., Ltd. shall not be liable for any such problem, nor grant a license therefore.

Measuring Circuit

1. Supply Current

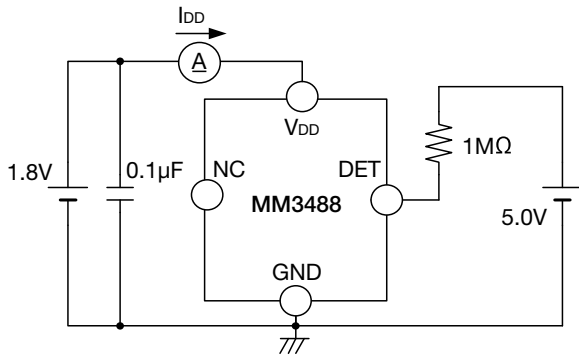

2. DET Sink Current

State of DET output Low level

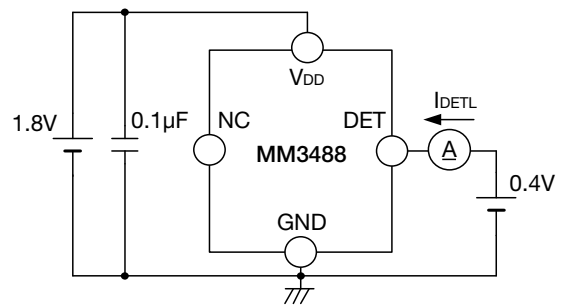

3. Start-up Response

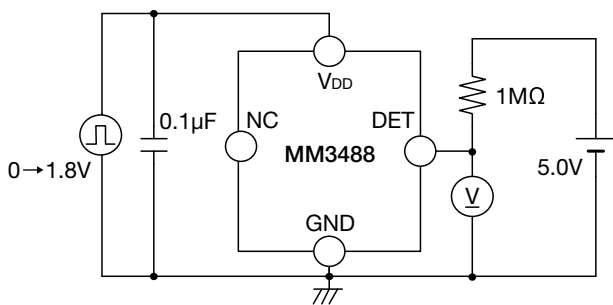

4. Detecting Temperature

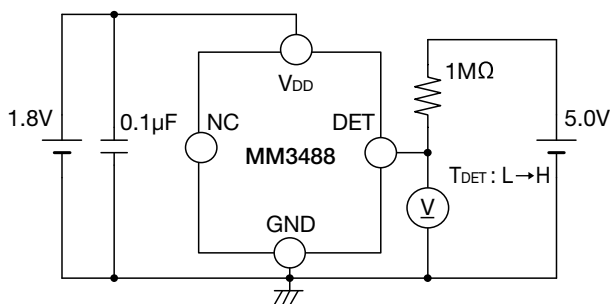

L : State of DET output Low level
 H : State of DET output Low level
 Ta = +40 → +100°C

5. Hysteresis Temperature

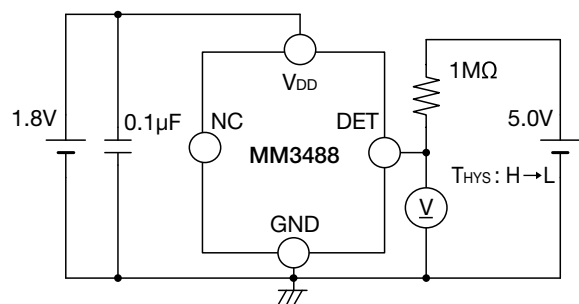

L : State of DET output Low level
 H : State of DET output Low level
 Ta = +100 → +40°C

Characteristics

Supply Voltage - Supply Current

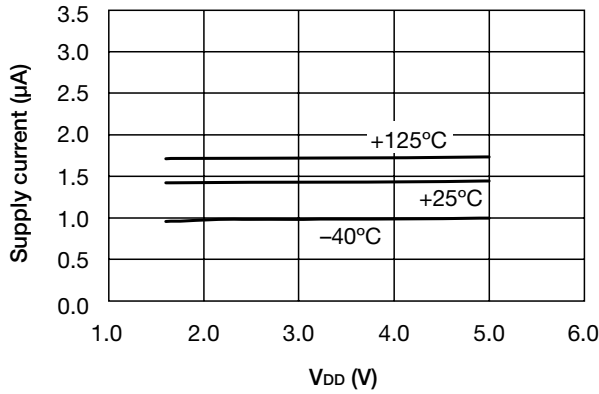

Ambient Temperature - Supply Current

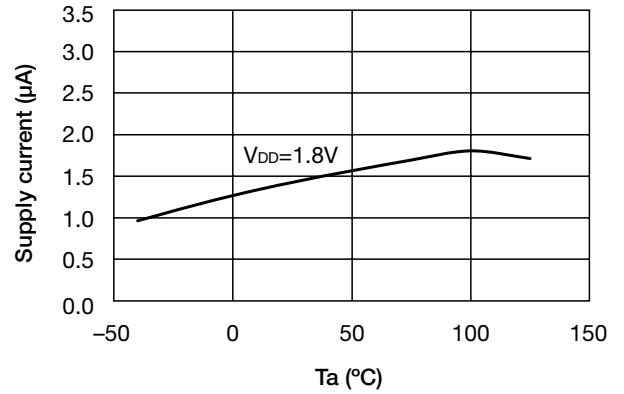

Supply Voltage - DET Sink Current

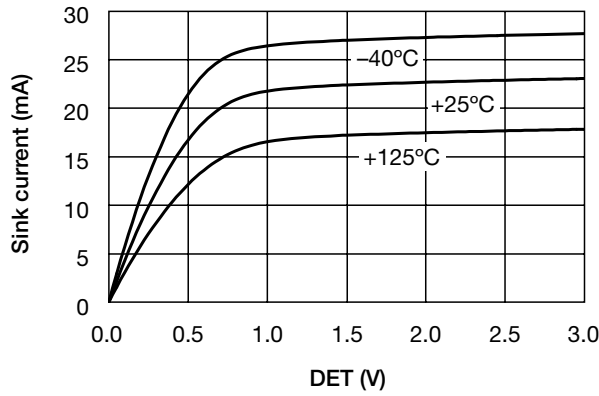

Ambient Temperature - DET Sink Current

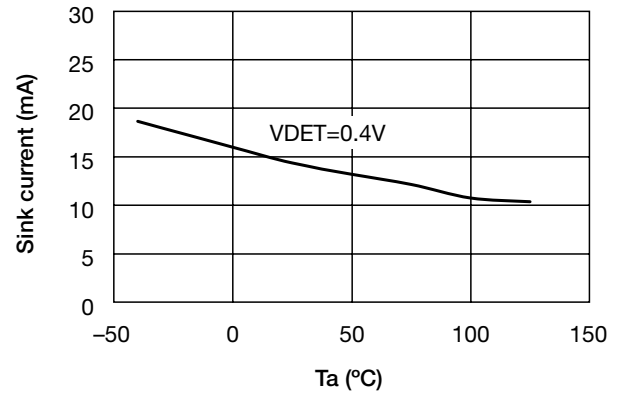

■ Start-up Response ($T_a < T_{DET}$)

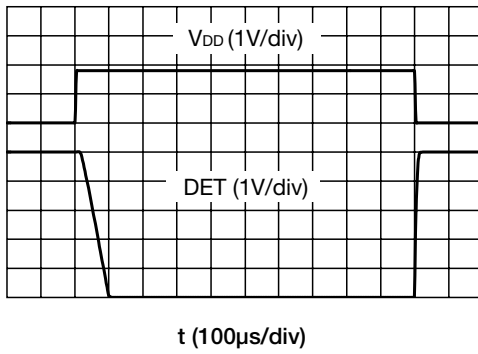

■ Start-up Response ($T_a \geq T_{DET}$)

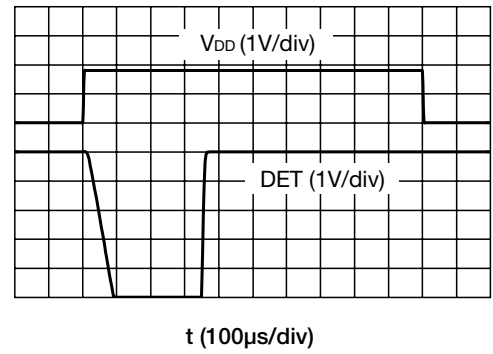

■ Supply Voltage - Noise Rejection Time

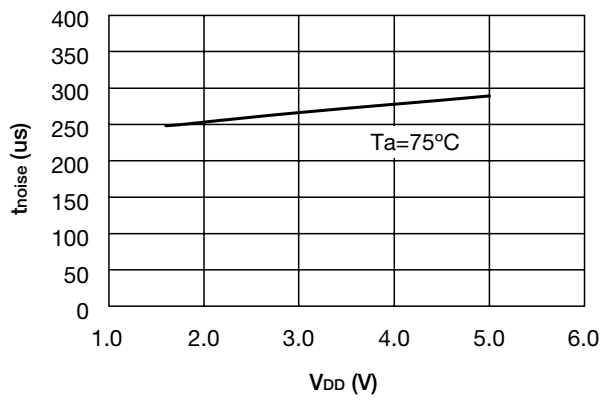

■ Ambient Temperature - Noise Rejection Time

