

# IC for CMOS System Reset

## Monolithic IC PST81XX, 82XX Series

### Outline

This IC functions in a variety of CPU systems and other logic systems, to detect supply voltage and reset the system accurately when the power is turned on or interrupted.

To  $\pm 1.5\%$  of detection voltage accuracy of the conventional models, a maximum of  $\pm 0.5\%$  of super-high precision is realized, and it is more suitable for battery detection etc. Moreover, the mounting area significantly contributes to space saving using the SSON package.

### Features

1. High Accuracy	$\pm 0.5\%$ typ. / 2.0~6.0V $\pm 0.8\%$ typ. / 0.8~1.9V
2. Ultra-low current consumption	0.25 $\mu$ A typ.
3. Ultra-small package	1.10 $\times$ 1.40mm (SSON-4)
4. Operating temperature range	-40~+105°C
5. Detecting voltage rank	0.8~6.0V (0.1V step)
6. Output configuration	PST81XX series ..... CMOS output PST82XX series ..... Open drain output

### Packages

SOT-25A  
SC-82ABA  
SC-82ABB  
SSON-4

### Applications

1. Reset circuits for microcomputers, CPUs and MPUs
2. Reset circuits for logic circuits
3. Battery voltage check circuits
4. Back-up power supply switching circuits
5. Level detection circuits

**Block Diagram**

■ PST81XX \*①-③ in the circuit diagram is pin number for the SOT-25A package.

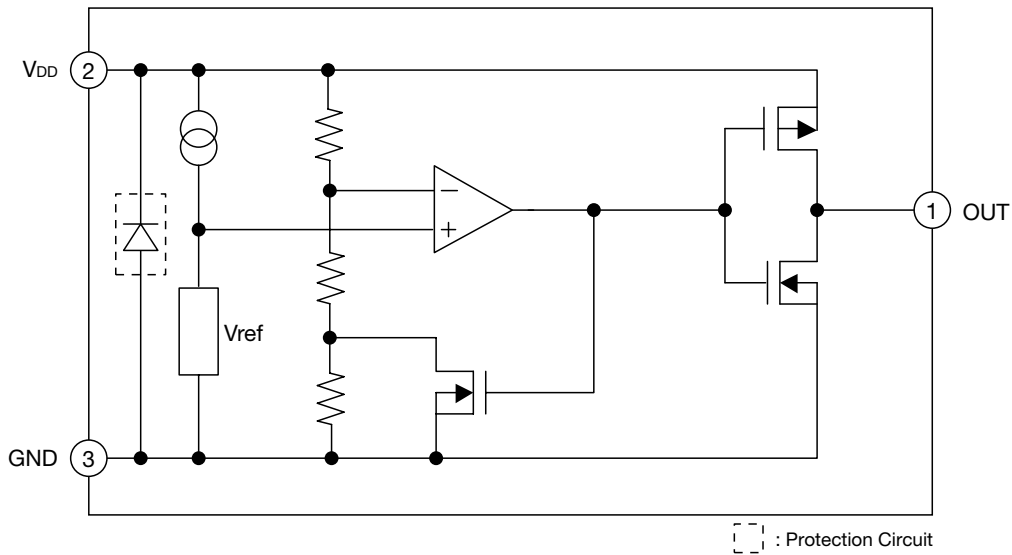

■ PST82XX \*①-③ in the circuit diagram is pin number for the SOT-25A package.

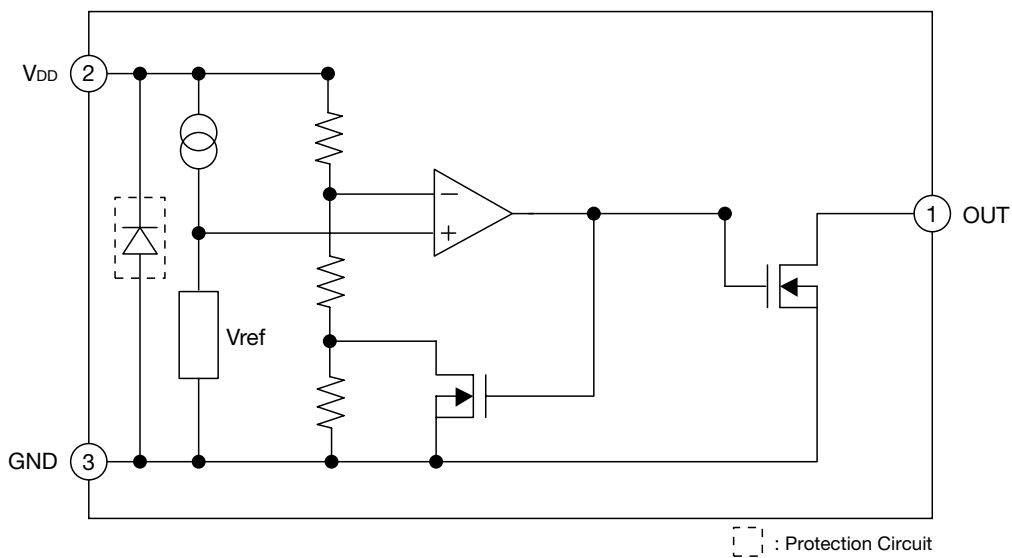

## Pin Assignment

### PST81XX, PST82XX

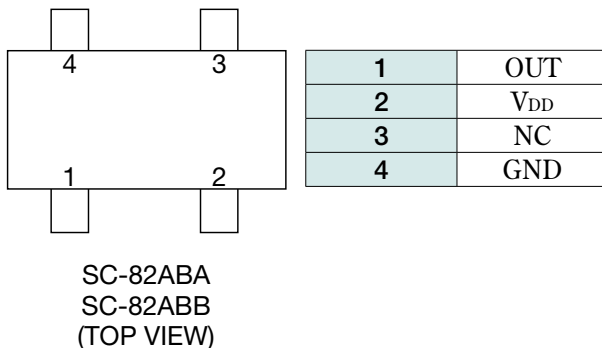
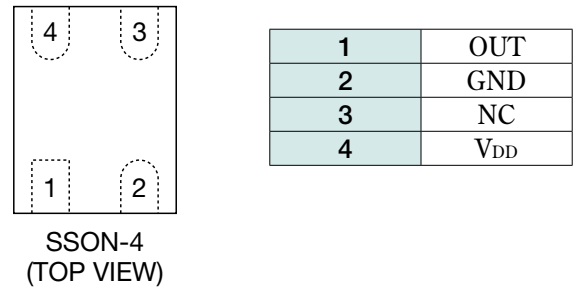
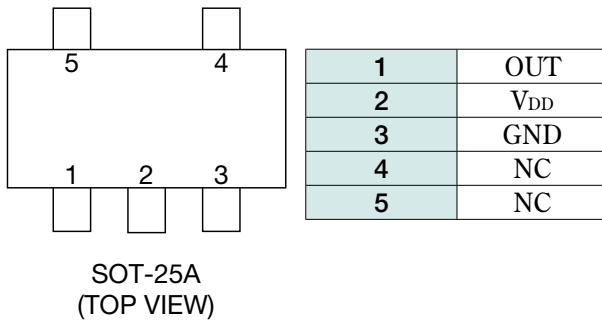

## Pin Description

### PST81XXNX, PST82XXNX (SOT-25A)

Pin No.	Pin name	Functions
1	OUT	Reset Signal Output Pin
2	V <sub>DD</sub>	V <sub>DD</sub> Pin / Voltage Detect Pin
3	GND	GND Pin
4	NC	No Connection
5	NC	No Connection

### PST81XXRX, PST82XXRX (SSON-4)

Pin No.	Pin name	Functions
1	OUT	Reset Signal Output Pin
2	GND	GND Pin
3	NC	No Connection
4	V <sub>DD</sub>	V <sub>DD</sub> Pin / Voltage Detect Pin

### PST81XXUX, PST82XXUX (SC-82ABA/-82ABB)

Pin No.	Pin name	Functions
1	OUT	Reset Signal Output Pin
2	V <sub>DD</sub>	V <sub>DD</sub> Pin / Voltage Detect Pin
3	NC	No Connection
4	GND	GND Pin

## Absolute Maximum Ratings

### ■ PST81XX

Item	Symbol	Ratings	Units
Supply voltage	$V_{DD\ max.}$	-0.3~+12.0	V
Output voltage	OUT	-0.3~( $V_{DD}+0.3$ )	V
Input current ( $V_{DD}$ )	$I_{DD}$	20	mA
Output current (RESET, $\overline{RESET}$ )	$I_{OUT}$	20	mA
Power Dissipation	$P_D$	150 (SOT-25A, SC-82AB) 330 (SSON-4) (note)	mW
Operating temperature	$T_{OPR}$	-40~+105	°C
Storage temperature	$T_{STG}$	-65~+150	°C

### ■ PST82XX

Item	Symbol	Ratings	Units
Supply voltage	$V_{DD\ max.}$	-0.3~+12.0	V
Output voltage	OUT	-0.3~+12.0	V
Input current ( $V_{DD}$ )	$I_{DD}$	20	mA
Output current (RESET, $\overline{RESET}$ )	$I_{OUT}$	20	mA
Power Dissipation	$P_D$	150 (SOT-25A, SC-82AB) 330 (SSON-4) (note)	mW
Operating temperature	$T_{OPR}$	-40~+105	°C
Storage temperature	$T_{STG}$	-65~+150	°C

note : With PC board of glass epoxy. (The tab pin is not connected with PC board.)  
PC board size of 110×40×0.8mm

## Recommended Operating Conditions

Item	Symbol	Ratings	Units
Operating temperature	$T_{OPR}$	-40~+105	°C
Supply voltage	$V_{DD}$	0.70~10.0	V

**Electrical Characteristics** (Except where noted otherwise Ta=25°C)

**PST81XX**

Item	Symbol	Measurement conditions	Min.	Typ.	Max.	Units	Circuit
Supply current	I <sub>DD</sub>	V <sub>DD</sub> =V <sub>TH</sub> +1V		0.25	1.0	μA	(1)
Reset threshold	V <sub>TH</sub>	Ta=+25°C V <sub>TH</sub> ≤1.9V	V <sub>TH</sub> -0.8%	V <sub>TH</sub> 0.8~ 6.0V (0.1Vstep)	V <sub>TH</sub> +0.8%	V	(2)
		Ta=-40~+85°C (note1)	V <sub>TH</sub> -2.5%		V <sub>TH</sub> +2.5%		
		Ta=+25°C V <sub>TH</sub> ≥2.0V	V <sub>TH</sub> -0.5%		V <sub>TH</sub> +0.5%		
		Ta=-40~+85°C (note1)	V <sub>TH</sub> -2.5%		V <sub>TH</sub> +2.5%		
Reset threshold hysteresis	ΔV <sub>TH</sub>	V <sub>DD</sub> =0V→V <sub>TH</sub> +1V→0V	V <sub>TH</sub> ×0.03		V <sub>TH</sub> ×0.08	V	(2)
Reset threshold temp. coefficient	ΔV <sub>TH</sub> /°C	Ta=-40~+85°C (note1)		±100		ppm/°C	(2)
L transfer delay time	t <sub>PHL</sub>	V <sub>DD</sub> =V <sub>TH</sub> +0.4V→V <sub>TH</sub> -0.4V(note2)			100	μs	(5)
H transfer delay time	t <sub>PLH</sub>	V <sub>DD</sub> =V <sub>TH</sub> -0.4V→V <sub>TH</sub> +0.4V(note2)			100	μs	(5)
"L" output current	I <sub>OL1</sub>	V <sub>DD</sub> =0.7V, V <sub>DS</sub> =0.05V	0.01	0.10		mA	(3)
	I <sub>OL2</sub>	V <sub>DD</sub> =1.2V, V <sub>DS</sub> =0.5V V <sub>TH</sub> >1.3V	0.23	2.00			
	I <sub>OL3</sub>	V <sub>DD</sub> =2.4V, V <sub>DS</sub> =0.5V V <sub>TH</sub> >2.5V	1.60	8.00			
	I <sub>OL4</sub>	V <sub>DD</sub> =3.6V, V <sub>DS</sub> =0.5V V <sub>TH</sub> >3.7V	3.20	12.0			
"H" output current	I <sub>OH1</sub>	V <sub>DD</sub> =4.8V, V <sub>DS</sub> =0.5V, V <sub>TH</sub> <4.7V	0.36	0.62		mA	(4)
	I <sub>OH2</sub>	V <sub>DD</sub> =6.1V, V <sub>DS</sub> =0.5V, V <sub>TH</sub> <5.9V	0.46	0.75			

note1 : This device is tested at Ta=25°C, over temperature limits guaranteed by design only.

note2 : The parameter is guaranteed by design.

**PST82XX**

Item	Symbol	Measurement conditions	Min.	Typ.	Max.	Units	Circuit
Supply current	I <sub>DD</sub>	V <sub>DD</sub> =V <sub>TH</sub> +1V		0.25	1.0	μA	(1)
Reset threshold	V <sub>TH</sub>	Ta=+25°C V <sub>TH</sub> ≤1.9V	V <sub>TH</sub> -0.8%	V <sub>TH</sub> 0.8~ 6.0V (0.1Vstep)	V <sub>TH</sub> +0.8%	V	(2)
		Ta=-40~+85°C (note1)	V <sub>TH</sub> -2.5%		V <sub>TH</sub> +2.5%		
		Ta=+25°C V <sub>TH</sub> ≥2.0V	V <sub>TH</sub> -0.5%		V <sub>TH</sub> +0.5%		
		Ta=-40~+85°C (note1)	V <sub>TH</sub> -2.5%		V <sub>TH</sub> +2.5%		
Reset threshold hysteresis	ΔV <sub>TH</sub>	V <sub>DD</sub> =0V→V <sub>TH</sub> +1V→0V	V <sub>TH</sub> ×0.03		V <sub>TH</sub> ×0.08	V	(2)
Reset threshold temp. coefficient	ΔV <sub>TH</sub> /°C	Ta=-40~+85°C (note1)		±100		ppm/°C	(2)
L transfer delay time	t <sub>PHL</sub>	V <sub>DD</sub> =V <sub>TH</sub> +0.4V→V <sub>TH</sub> -0.4V(note2)			100	μs	(4)
H transfer delay time	t <sub>PLH</sub>	V <sub>DD</sub> =V <sub>TH</sub> -0.4V→V <sub>TH</sub> +0.4V(note2)			100	μs	(4)
"L" output current	I <sub>OL1</sub>	V <sub>DD</sub> =0.7V, V <sub>DS</sub> =0.05V	0.01	0.10		mA	(3)
	I <sub>OL2</sub>	V <sub>DD</sub> =1.2V, V <sub>DS</sub> =0.5V V <sub>TH</sub> >1.3V	0.23	2.00			
	I <sub>OL3</sub>	V <sub>DD</sub> =2.4V, V <sub>DS</sub> =0.5V V <sub>TH</sub> >2.5V	1.60	8.00			
	I <sub>OL4</sub>	V <sub>DD</sub> =3.6V, V <sub>DS</sub> =0.5V V <sub>TH</sub> >3.7V	3.20	12.0			
Output leakage current	I <sub>leak</sub>	V <sub>DD</sub> =10V, OUT=10V			0.1	μA	(3)

note1 : This device is tested at Ta=25°C, over temperature limits guaranteed by design only.

note2 : The parameter is guaranteed by design.

## Measuring Circuit

■ PST81XX \*①-③ in the circuit diagram is pin number for the SOT-25A package.

(1)  $I_{DD}$

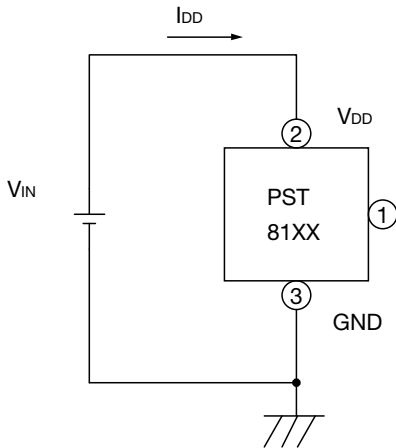

(2)  $V_{TH}$ ,  $\Delta V_{TH}$ ,  $\Delta V_{TH}/^{\circ}C$

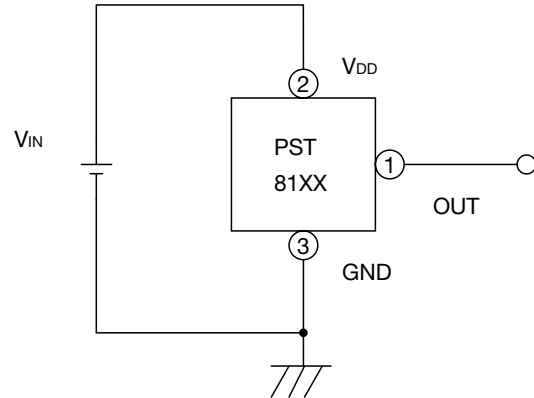

(3)  $I_{OL1}$ ,  $I_{OL2}$ ,  $I_{OL3}$ ,  $I_{OL4}$

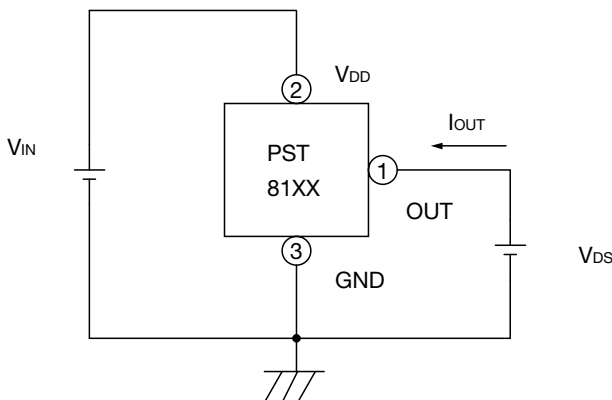

(4)  $I_{OH1}$ ,  $I_{OH2}$

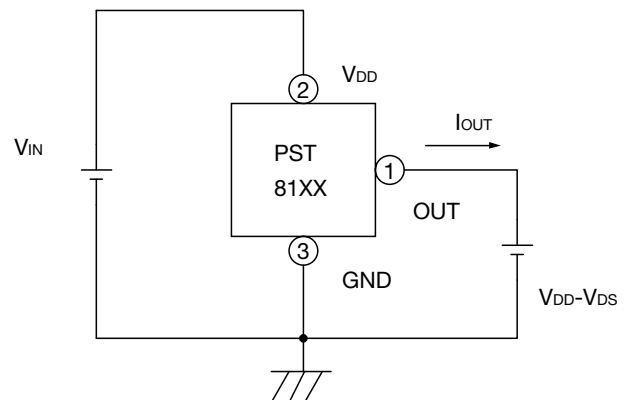

(5)  $t_{PLH}$ ,  $t_{PHL}$

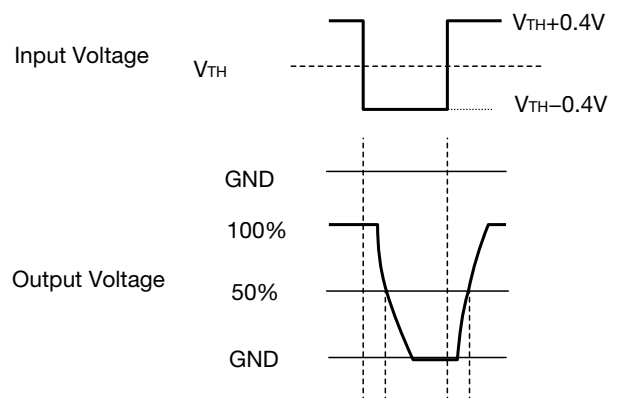
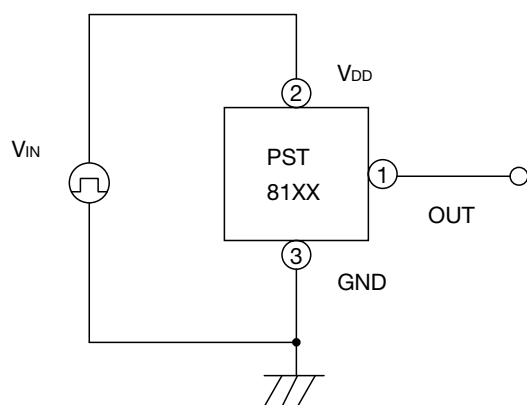

■ PST82XX \*①-③ in the circuit diagram is pin number for the SOT-25A package.

(1)  $I_{DD}$

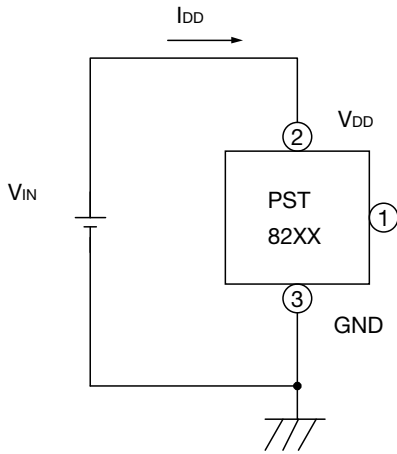

(2)  $V_{TH}$ ,  $\Delta V_{TH}$ ,  $\Delta V_{TH}/^{\circ}C$

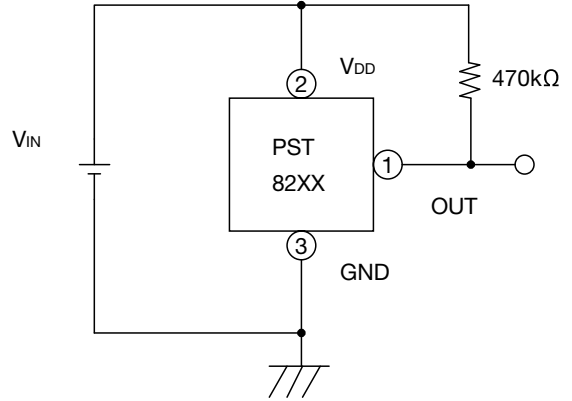

(3)  $I_{OL1}$ ,  $I_{OL2}$ ,  $I_{OL3}$ ,  $I_{OL4}$ ,  $I_{leak}$

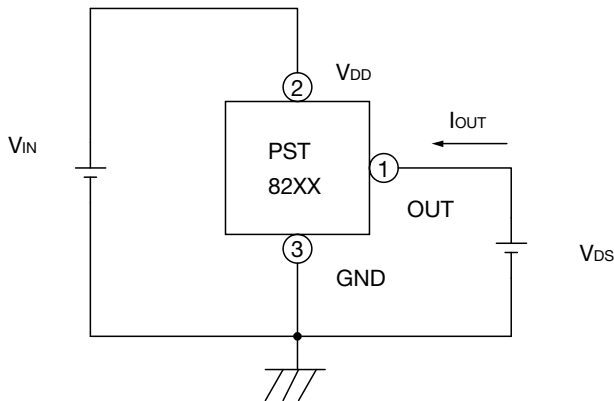

(4)  $t_{PLH}$ ,  $t_{PHL}$

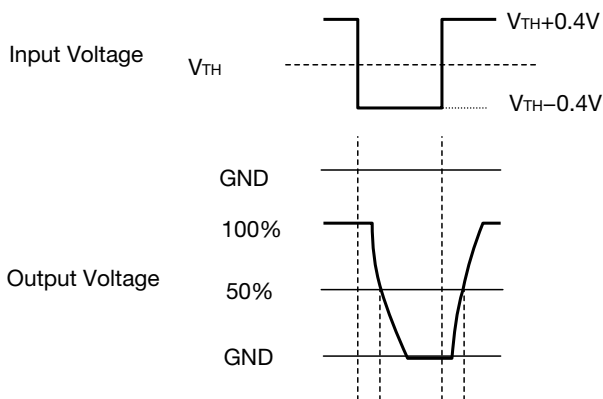
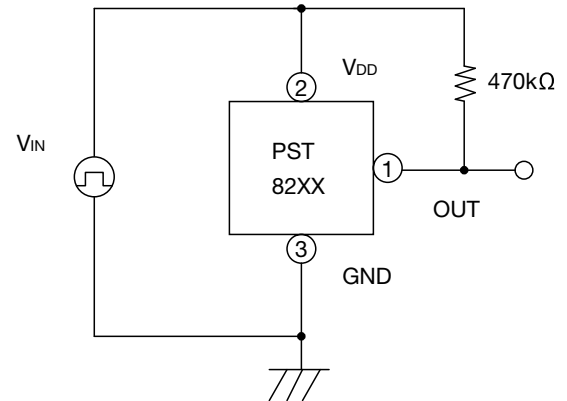

Timing Chart

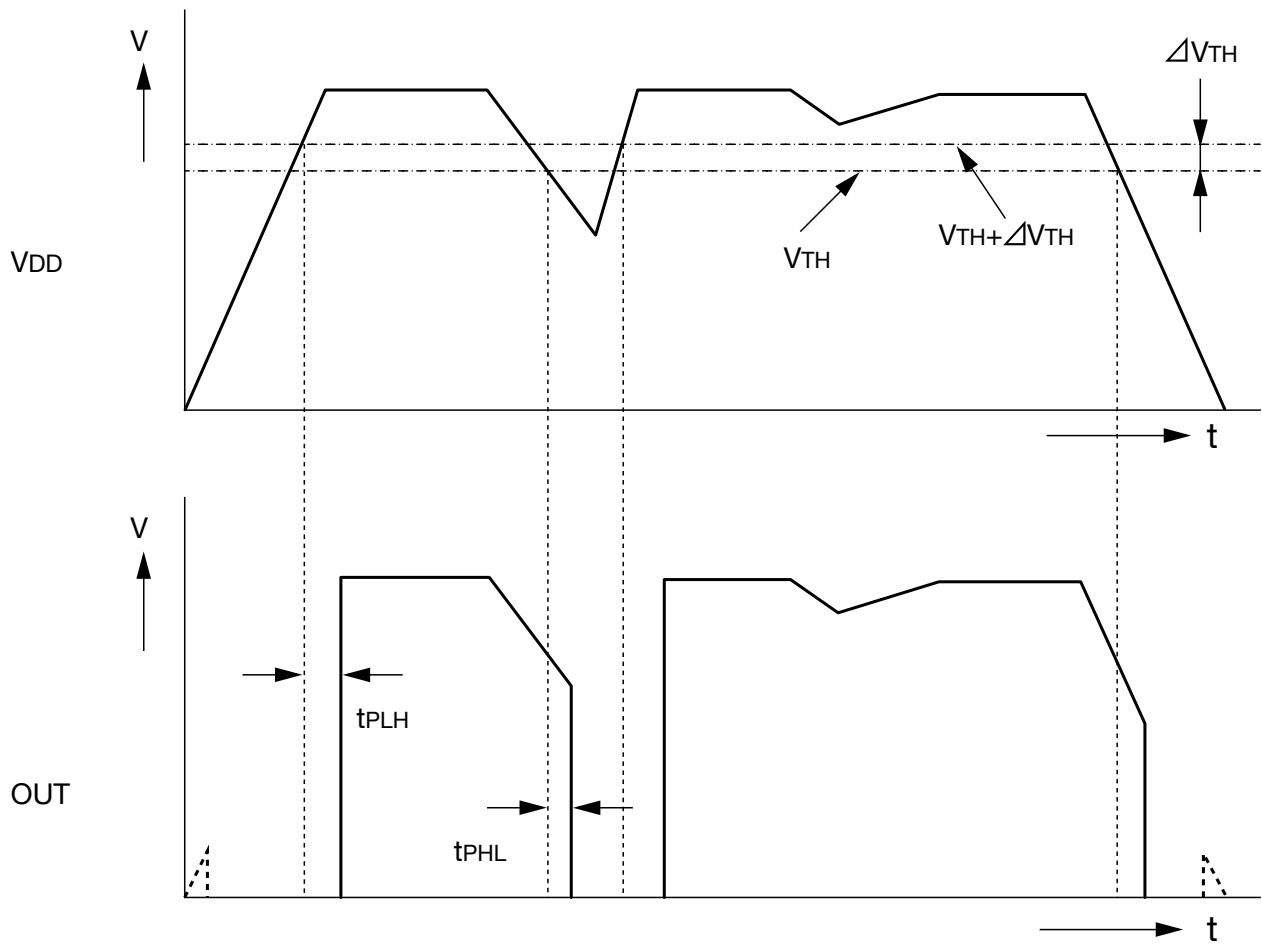

Application Circuits

■ PST81XX \*①-③ in the circuit diagram is pin number for the SOT-25A package.

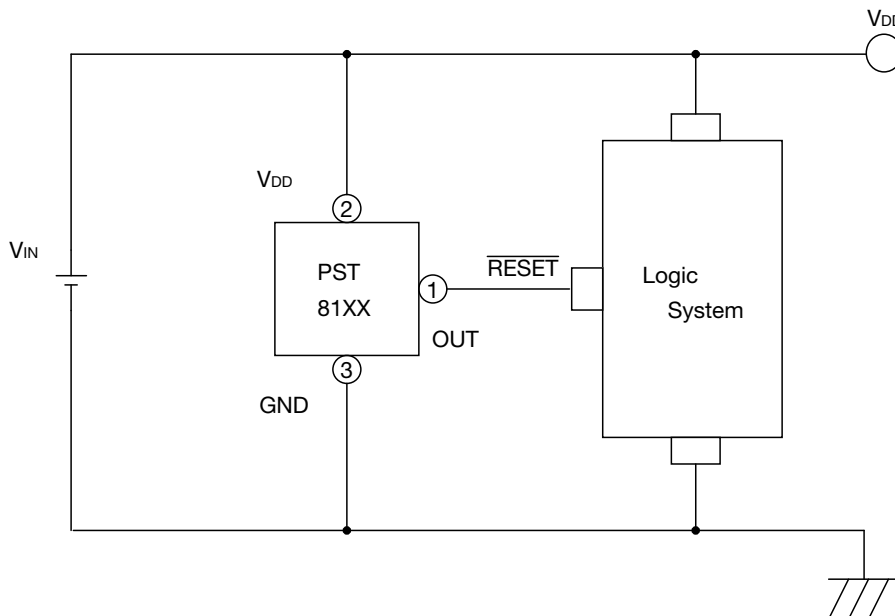

• Any products mentioned in this catalog are subject to any modification in their appearance and others for improvements without prior notification.  
 • The details listed here are not a guarantee of the individual products at the time of ordering. When using the products, you will be asked to check their specifications.

■ PST82XX \*①-③ in the circuit diagram is pin number for the SOT-25A package.

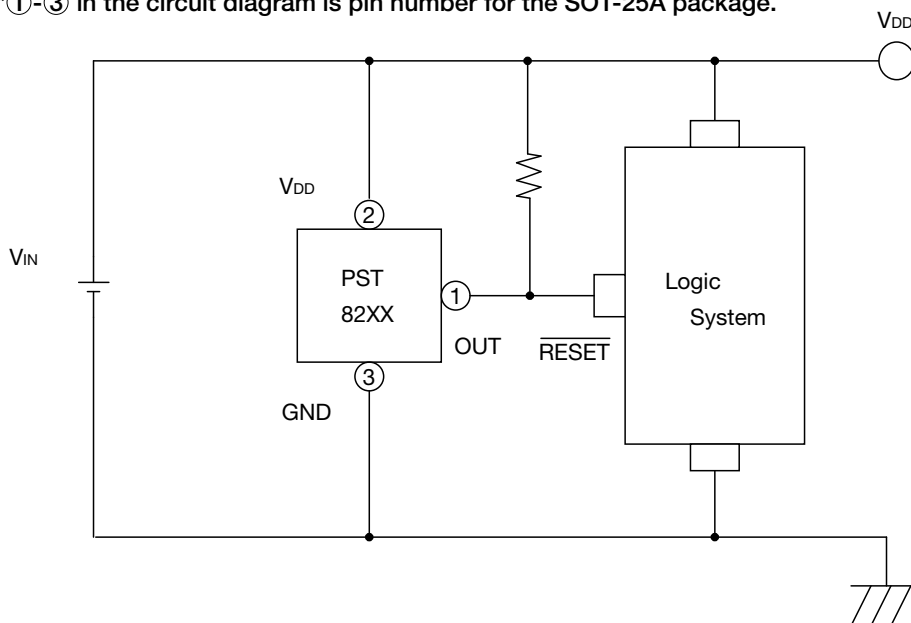

- We shall not be liable for any trouble or damage caused by using this circuit.
- In the event a problem which may affect industrial property or any other rights of us or a third party is encountered during the use of information described in these circuit, Mitsumi Electric Co., Ltd. shall not be liable for any such problem, nor grant a license therefore.

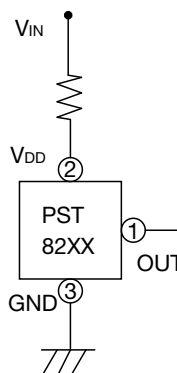
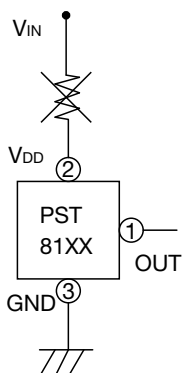

- Please note that there is any possibility of circuit oscillation when resistance put in the line  $V_{IN}$ .
- Please do not put resistance for PST81XX.
- Recommend 15kΩ or less for PST82XX.

**Characteristics** (Typical Performance Characteristics 2.8V)

**Detecting Voltage**

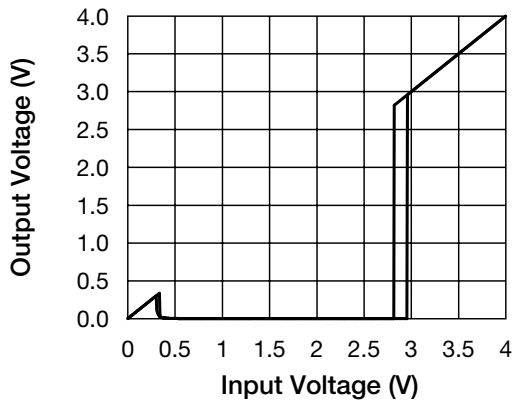

**Supply Current**

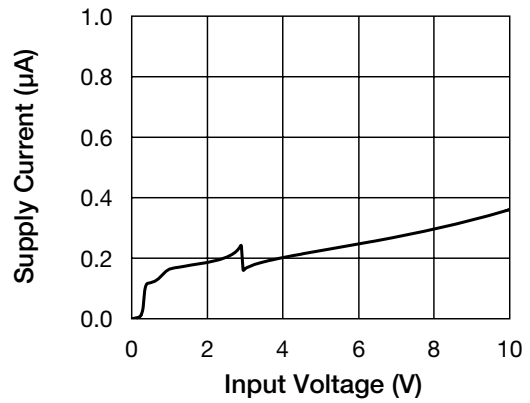

**Detecting Voltage - Temperature**

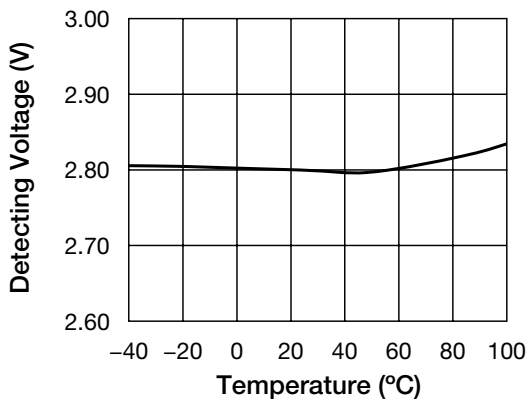

**Hysteresis Voltage - Temperature**

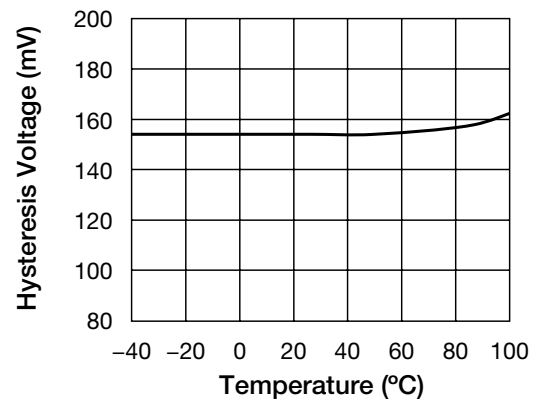

note : these are typical characteristics

■ "L" Output Current 1 - Temperature

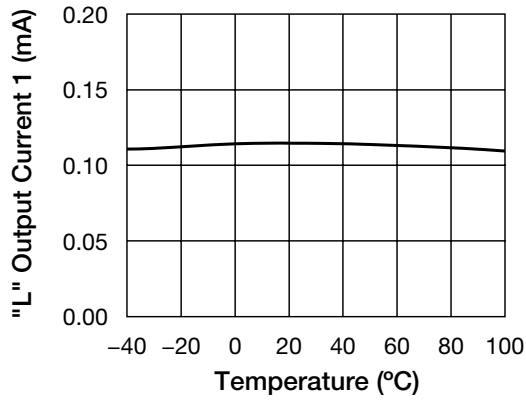

■ "L" Output Current 2 - Temperature

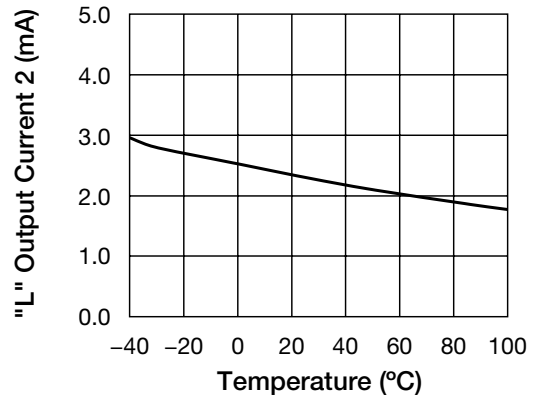

■ "L" Output Current 3 - Temperature

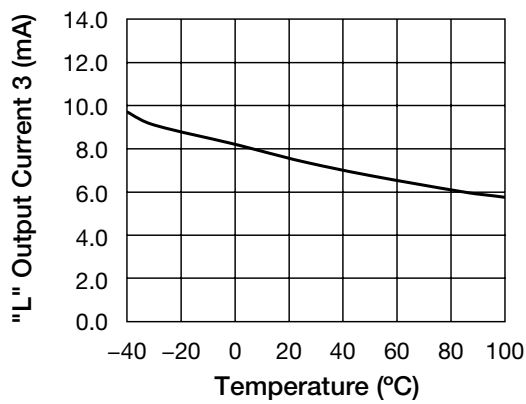

note : these are typical characteristics