

System Reset with Delay Time Circuit Monolithic IC PST596~598 Series

July 21, 2000

Outline

This IC functions in a variety of CPU systems and other logic systems, to detect supply voltage and reset the system accurately when the power is turned on or interrupted. It incorporates a fixed-delay time generation circuit. In particular, this IC is a system reset IC which realizes ultra-small size and low current consumption.

Features

- | | |
|------------------------------------------------------|---------------------------------------------------------------------------------------------------------------------------------------------------------------------------|
| 1. Fixed delay time setting by counter timer | |
| 2. Low operating limit voltage | 0.65V typ. |
| 3. Hysteresis voltage provided for detection voltage | 50mV typ. |
| 4. Low current consumption | I _{CCH} =15μA typ. |
| 5. 3 models are available for different delay times. | PST596 50ms
PST597 100ms
PST598 200ms |
| 6. Each model has 10 detection voltage ranks. | C: 4.5V typ. H: 3.1V typ.
D: 4.2V typ. I : 2.9V typ.
E: 3.9V typ. J : 2.7V typ.
F: 3.6V typ. K: 2.5V typ.
G: 3.3V typ. L : 2.3V typ. |

Package

SOT-25A (PST59×□N) (with manual reset pin)
*The box represents a rank of detection voltage.

Applications

1. Reset circuits for microcomputers, CPUs and MPUs
2. Reset circuits for logic circuits
3. Battery voltage check circuits
4. Back-up power supply switching circuits
5. Level detection circuits
6. Mechanical reset circuits

Equivalent Circuit Diagram

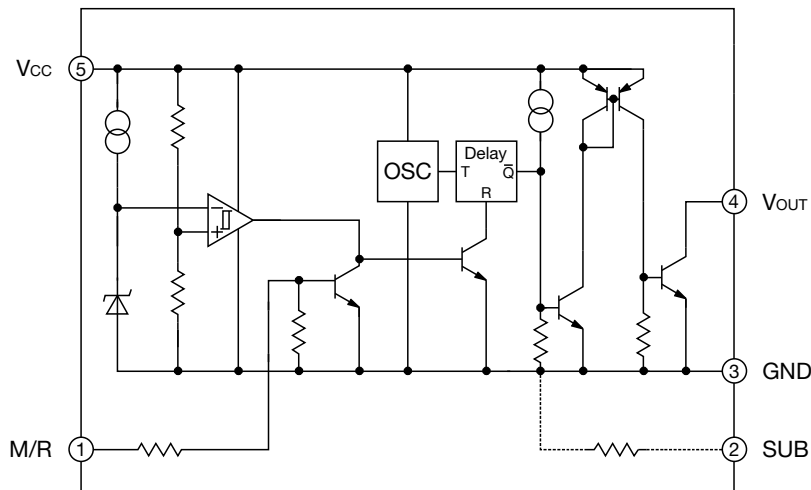

Pin Assignment

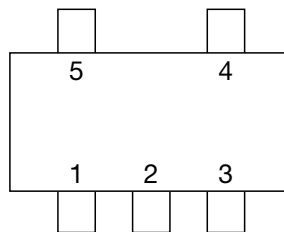

SOT-25
(TOP VIEW)

1	M/R
2	SUB
3	GND
4	V _{OUT}
5	V _{CC}

Pin Description

Pin No.	Pin name	Function
1	M/R	Manual reset pin *1
2	SUB	SUB pin *2
3	GND	GND pin
4	V _{OUT}	Reset signal output pin
5	V _{CC}	Power supply pin/Voltage detection pin

*1 : Note that the oscilloscope may mis-operate if the M/R pin falls below -0.3V.

*2 : Connect to GND.

Absolute Maximum Ratings (Except where noted otherwise Ta=25°C)

Item	Symbol	Ratings	Units
Storage temperature	T _{STG}	-40~+125	°C
Operating temperature	T _{OPR}	-20~+75	°C
Power supply voltage	V _{CC} max.	-0.3~+12	V
Manual reset input voltage	V _{RES} max.	-0.3~+12	V
Allowable loss	P _d	150	mW

• Any products mentioned in this catalog are subject to any modification in their appearance and others for improvements without prior notification.
 • The details listed here are not a guarantee of the individual products at the time of ordering. When using the products, you will be asked to check their specifications.

Recommended Operating Conditions

Item	Symbol	Ratings	Units
Operating temperature	T _{OPR}	-20~+75	°C
Power supply voltage	V _{CC}	-0.3~+12	V

Electrical Characteristics (T_a=25°C) (Except where noted otherwise, resistance unit is Ω)

Item	Symbol	Measuring circuit	Measurement conditions	Min.	Typ.	Max.	Units	
Detection voltage	V _S	1	V _{CC} =H→L R _L =470 V _{OL} ≤0.4V	C	4.3	4.5	4.7	V
				D	4.0	4.2	4.4	
				E	3.7	3.9	4.1	
				F	3.4	3.6	3.8	
				G	3.1	3.3	3.5	
				H	2.9	3.1	3.3	
				I	2.75	2.90	3.05	
				J	2.55	2.70	2.85	
				K	2.35	2.50	2.65	
				L	2.15	2.30	2.45	
Hysteresis voltage	ΔV _S	1	V _{CC} =L→H→L, R _L =470	30	50	100	mV	
Detection voltage temperature coefficient	V _S /ΔT	1	R _L =470, T _a =-20°C~+75°C		±0.01		%/°C	
Low-level output voltage	V _{OL}	1	V _{CC} =V _S min. -0.05V, R _L =470		0.1	0.4	V	
Output leakage current	I _{OH}	1	V _{CC} =10V			±0.1	μA	
Circuit current while on	I _{CCL}	1	V _{CC} =V _S min. -0.05V, R _L =∞		300	500	μA	
Circuit current while off	I _{CCH}	1	V _{CC} =V _S typ. / 0.85V, R _L =∞		15	25	μA	
"H" transport delay time	T _{PLH}	2	R _L =4.7k C _L =100pF * 1	PST596	30	50	75	ms
				PST597	60	100	150	
				PST598	120	200	300	
"L" transport delay time	T _{PHL}	2	R _L =4.7k, C _L =100pF, *2		20		μs	
Operating power supply voltage	V _{OPL}	1	R _L =4.7k, V _{OL} ≤0.4V		0.65	0.85	V	
Output current while on 1	I _{OL1}	1	V _{CC} =V _S min. -0.05V, R _L =0	8			mA	
Output current while on 2	I _{OL2}	1	V _{CC} =V _S min. -0.05V, R _L =0 T _a =-20~+75°C	6			mA	
M/R pin input H voltage	V _{RESH}			2.0			V	
M/R pin input H current	I _{RESH}		V _{RESH} =2.0V		10	60	μA	
M/R pin input low voltage	V _{RESL}			-0.3		0.8	V	

*1 : T_{PLH} ; V_{CC}= (V_S typ.-0.4V) → (V_S typ.+0.4V)

*2 : T_{PLH} ; V_{CC}= (V_S typ.+0.4V) → (V_S typ.-0.4V)

Note 3: Connect manual reset pin to GND when not using.

Measuring Circuit

[1]

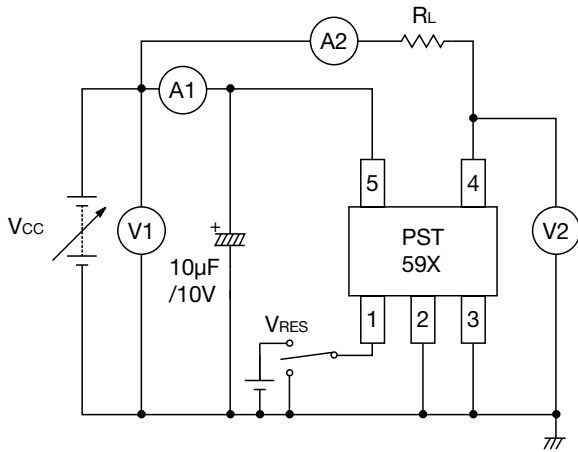

[2]

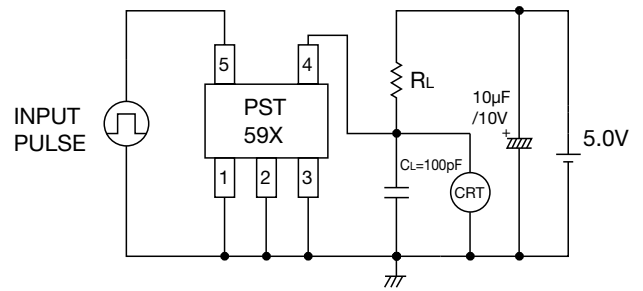

A : DC ammeter
 V : DC voltmeter
 CRT : Oscilloscope

INPUT PULSE

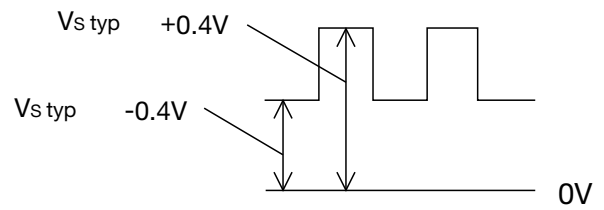

Timing Chart

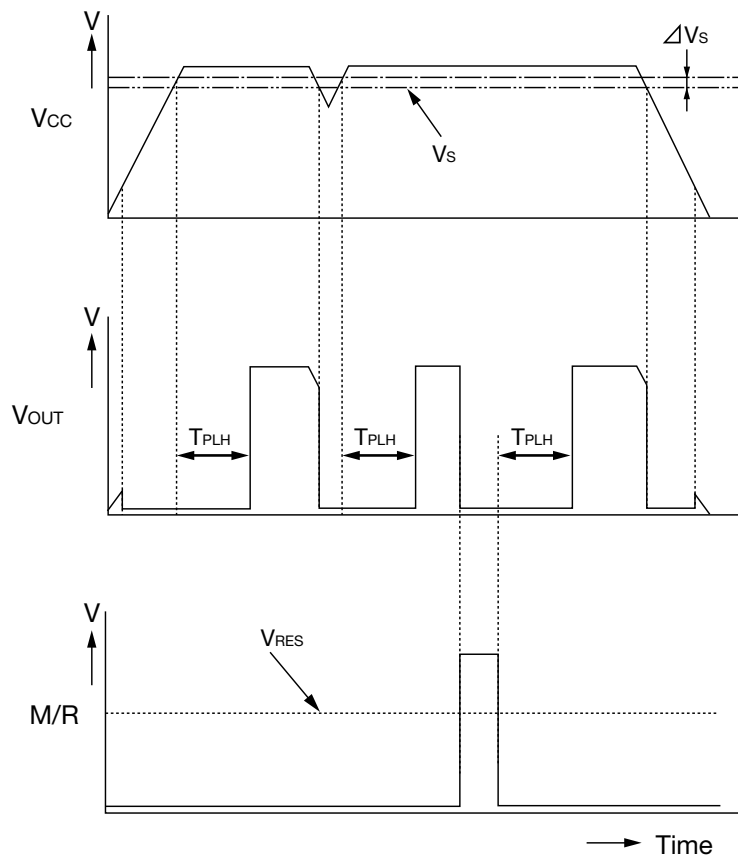

Note : Thoroughly check the actual operation of the circuit, then set the manual reset when pressing the manual switch ON to about 15µs.

Application Circuits

1. Normal hard reset

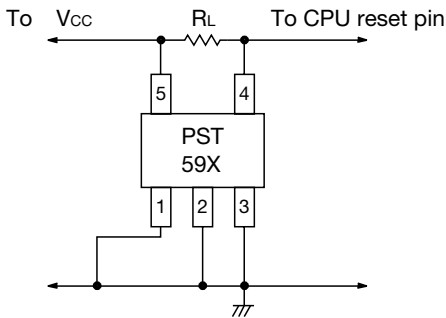

Note : Connect a capacitor between IC Vcc and GND pins if Vcc line impedance is high.

2. Manual reset

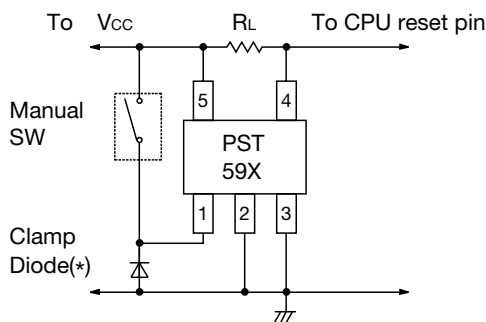

V_{OUT} pin low for manual switch ON.

V_{OUT} pin high for manual switch OFF.

Note1 : *Mount a clamp diode if it is possible that the M/R pin might go below -0.3V.

Note2 : Thoroughly check the actual operation of the circuit, then set the manual reset when pressing the manual switch ON to about 15μs.

Characteristics

V_{CC} vs V_{OUT}

