

Lithium-Ion Battery Charge Control IC

Monolithic IC MM3358

Outline

This IC is a linear charge control IC for 1-cell Lithium-Ion and lithium-polymer batteries.

It incorporates a power MOSFET and a reverse-current block circuit for easy implementation of charge control of Lithium-Ion and Lithium-polymer batteries without an external sense resistor and a reverse-blocking diode.

The chip temperature detection function can limit the temperature rise in the IC during high power charging and the temperature detection function enables the temperature for charge to be controlled.

This IC uses a small PLP-10pin package.

Features

1. BAT Regulation Voltage 4.2V±30mV(±0.7%)
2. Fast Charge Current 558mA±5%(RICHG=2.32kΩ)
3. The external resistor enables trickle/fast-charge current/charge completion current to be set (Maximum charge current : 1.5A).
4. A charge timer is embedded in this IC. The external resistor enables the charge timer to be set arbitrarily.
5. The chip temperature detection function can limit the temperature rise in the IC during high power charging. It can be charged at an optimal rate.
6. The battery temperature detection function with thermistor input enable the temperature for charge to be controlled.
7. LED Driver (1ch)
8. 10pin Small Package; PLP-10(2.5×2.7×0.6mm max.)

Package

PLP-10

Applications

1. Cellular phones
2. Portable music players
3. PDAs
4. Digital still cameras
5. Portable game devices

Block Diagram

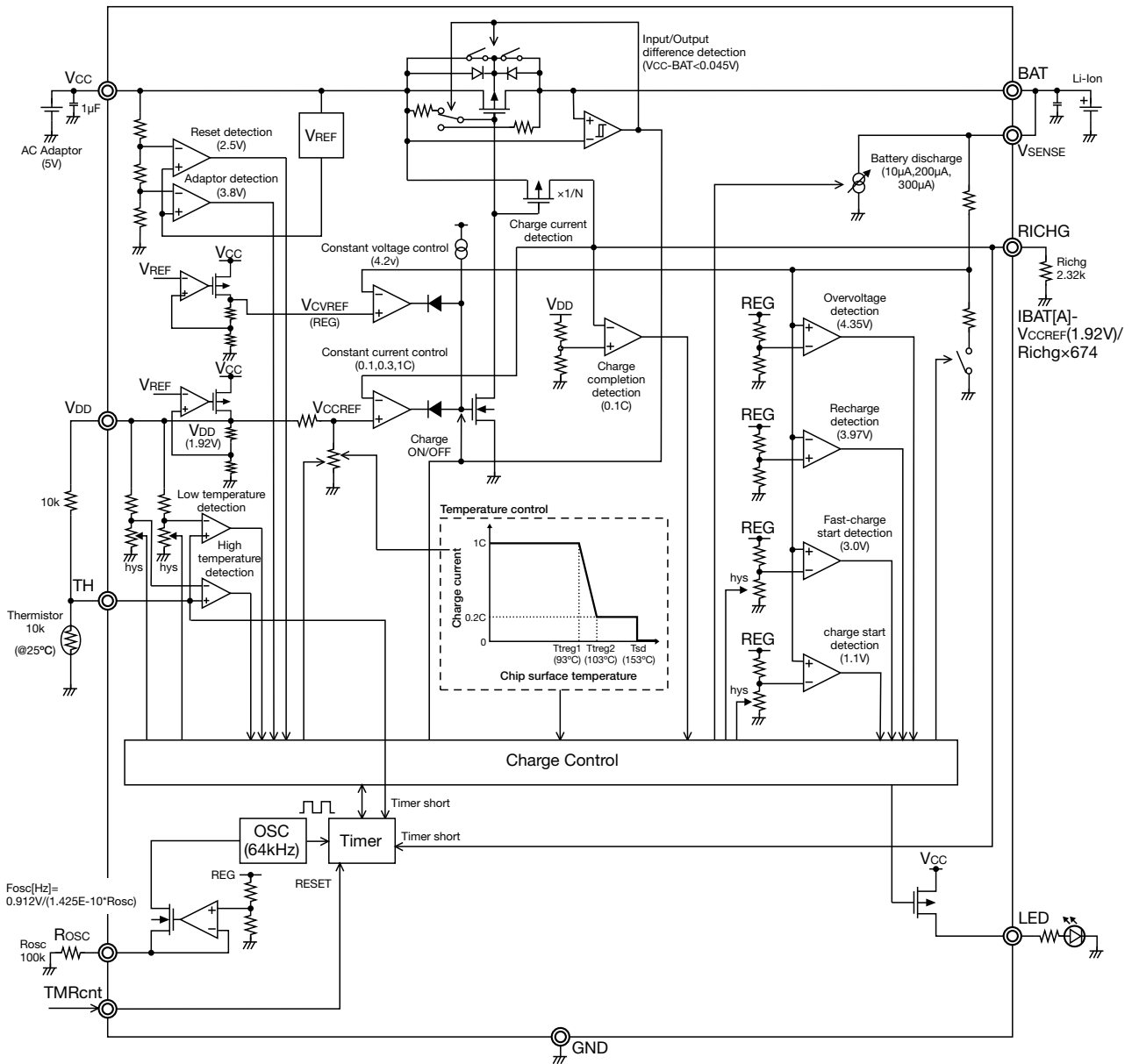

• Any products mentioned in this catalog are subject to any modification in their appearance and others for improvements without prior notification.
 • The details listed here are not a guarantee of the individual products at the time of ordering. When using the products, you will be asked to check their specifications.

Pin Assignment

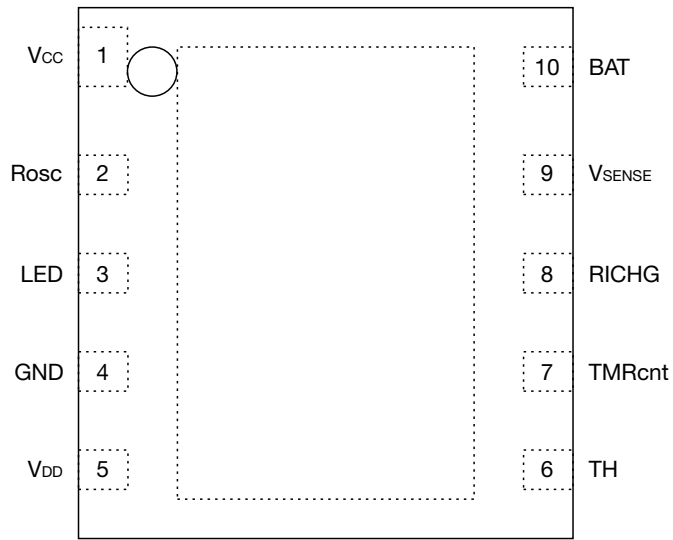

PLP-10
(TOP VIEW)

1	V _{CC}	6	TH
2	R _{osc}	7	TMRcnt
3	LED	8	RICHG
4	GND	9	V _{SENSE}
5	V _{DD}	10	BAT

Pin Description

Pin No.	Symbol	Function
1	V _{CC}	Power supply, charge Tr input pin. Connect to an AC adaptor.
2	Rosc	Oscillation frequency setting resistance connection pin $f_{osc}=0.912V/(1.425E-10 \star Rosc)$ * Estimation : The fosc value for each Rosc value is specified on Flow Chart.
3	LED	LED connect pin (Pch open drain output) Turn on during charging.
4	GND	Ground pin
5	V _{DD}	Battery temperature detecting reference voltage pin * It is not recommended to be used other than as battery temperature detecting reference voltage (resistance connection) since it is also used for internal charge current reference voltage.
6	TH	Battery temperature detection input pin. Connect to a thermistor. Used for both a timer and a Blinking cycle time reduction pin Enter time reduction mode when TH>(V _{CC} -approx.1.0V), V _{CC} >3.8V, and when maintaining 32ms×2.
7	TMRcnt	Timer (trickle charge timer, fast charge timer) ON/OFF control pin High: Timer stops, Low/open: Timer is valid.
8	RICHG	Charge current setting resistance connection pin $ICHG=674 \times 1.92V/RICHG$ * Estimation: The ICHG value for each RICHG value is specified on Flow Chart. Used for both a timer and a blinking cycle time reduction pin Enter time reduction mode when RICHG>(V _{CC} -approx. 1.0V), V _{CC} >3.8V, and when maintaining 32ms×2.
9	V _{SENSE}	Battery voltage detection, constant voltage charge control pin Connect to the positive side of a battery pack.
10	BAT	Charge Tr output pin Connect to the positive side of a battery pack.

Absolute Maximum Ratings

Item	Symbol	Ratings	Units
Storage temperature	T _{STG}	-55~+150	°C
Operating temperature	T _{OPR}	-40~+85	°C
V _{CC} , Rosc, V _{DD} , TH, TMRcnt, RICHG, V _{SENSE} , BAT pin voltage	V _{in}	-0.3~+6.0	V
BAT pin output current	IBAT	1.5	A
LED pin output current	I _{LED}	20	mA
Power dissipation	P _d	2.25 (*1)	W

note : *1 When mounted on a 40 × 40 × 1.6mm (Copper foil area 50%, FR4) PC board.

Recommended Operating Conditions

Item	Symbol	Ratings	Units
Operating temperature	T _{OPR}	0~+45	°C
V _{CC} Operating voltage	V _{op}	4.0~6.0	V

Electrical Characteristics (Except where noted otherwise Ta=0~45°C, V_{CC}=5V)

Item	Symbol	Measurement conditions	Min.	Typ.	Max.	Units
Supply current 1	I _{cc1}	During fast charge (I _{rapchg} = 500mA setting)		3.0	4.5	mA
Supply current 2 (*1)	I _{cc2}	During fast charge (I _{rapchg} = 1000mA setting)		3.5	5.2	mA
Leak current 1	I _{leak}	Inflow current of BAT/V _{SENSE} pin under the following conditions : 1. BAT (=V _{SENSE})=4.2V AC adaptor is unconnected 2. V _{CC} =4.8V charging is completed		1	2	μA
Leak current 1 (*1)	I _{leak}	Inflow current of BAT/V _{SENSE} pin under the following condition: 1. BAT (=V _{SENSE})=1.0~4.2V AC adaptor unconnected		1	2	μA
Reset detection voltage	V _{por}	Reset mode when V _{CC} <V _{POR}	2.3	2.5	2.7	V
ADP detection voltage	V _{adp}	Charging stops when V _{CC} <V _{adp}	3.6	3.8	4.0	V
V _{SENSE} pin discharge current 1	I _{dischg1}	V _{SENSE} (=BAT)=3.2V in charge error mode		10	20	μA
V _{SENSE} pin discharge current 2	I _{dischg2}	V _{SENSE} (=BAT)=3.2V	100	200	300	μA
Charge start detection voltage	V _{start}	Used for battery connection detection as well Charging stops when V _{SENSE} (=BAT)<V _{start}	1.0	1.1	1.2	V
Charge start detection voltage hysteresis	V _{starthys}	Not applied to battery voltage detection immediately after reset release	50	100	150	mV
Fast-charge start detection voltage	V _{qchg}		2.9	3.0	3.1	V
Fast-charge start detection voltage hysteresis	V _{qchgonhys}	Applied to detection voltage from fast charge to trickle charge	40	80	120	mV
Recharge detection voltage	V _{rechg}	Charging restarts when V _{SENSE} (=BAT)<V _{rechg}	3.87	3.97	4.07	V
BAT regulation voltage	V _{chg}		4.17	4.20	4.23	V
Charge stop I/O potential difference 1	V _{def1}	Charge stops when V _{CC} -BAT<V _{def1} V _{CC} =High→Low	5	30	65	mV
Charge stop I/O potential difference 2	V _{def2}	Charge stops when V _{CC} -BAT<V _{def2} V _{CC} =Low→High	5	45	65	mV
Battery overvoltage detection voltage	V _{ov}	V _{CC} >V _{ov} +100mV	4.27	4.35	4.43	V

note : *1 The parameter is guaranteed by design.

Item	Symbol	Measurement conditions	Min.	Typ.	Max.	Units
Forced charge current	Istart	RICHG=2.32kΩ 0.3C (1.0C=Irapchg)	116	167	219	mA
Trickle-charge current	Iprechg	RICHG=2.32kΩ 0.1C (1.0C=Irapchg) BAT=2.6V	40	56	72	mA
Trickle-charge current (★1)	Iprechg(★)	RICHG=2.32kΩ 0.1C (1.0C=Irapchg) BAT=Vstart-Vqchgon	40	56	72	mA
Fast-charge current	Irapchg	RICHG=2.32kΩ 1.0C BAT=3.6V	530	558	586	mA
Fast-charge current (★1)	Irapchg(★)	RICHG=2.32kΩ 1.0C BAT=Vqchgon-Vchg	530	558	586	mA
Fast-charge current2	Irapchg2	RICHG=1.30kΩ 1.0C BAT=3.6V		1000		mA
Charge completion current	Ifc	RICHG=2.32kΩ BAT=Vqchgon	40	56	72	mA
Charge completion current (★1)	Ifc(★)	RICHG=2.32kΩ BAT>Vqchgon	40	56	72	mA
Chip temperature detection1(★1)	Ttreg1	Applied to Tj (chip temperature)	83	93	103	°C
Chip temperature detection2(★1)	Ttreg2	Applied to Tj (chip temperature)		103		°C
Chip temperature detection difference (★1)	Tdtreg	Applied to Tj (chip temperature) Ttreg2-Ttreg1	5	10	15	°C
Thermal shutdown temperature (★1)	Tsd	Applied to Tj (chip temperature)	143	153	163	°C
Temperature detecting reference voltage	VDD	VDD pin Output Voltage		1.92		V
Temperature detecting reference terminal current (★1)	IDD	VDD pin Output Current		3		mA
Charge stop temperature detection voltage (Low temperature)	VthSL	Charge stop threshold when TH pin rises (2°C)	VDD× 0.6966	VDD× 0.7142	VDD× 0.7313	V
Charge stop temperature detection voltage (High temperature)	VthSH	Charge stop threshold when TH pin falls (43°C)	VDD× 0.3296	VDD× 0.3448	VDD× 0.3604	V
Charge recovery temperature detection voltage (Low temperature)	VthRL	Charge recovery threshold when TH pin falls (4°C)	VDD× 0.6787	VDD× 0.6966	VDD× 0.7141	V
Charge recovery temperature detection voltage (High temperature)	VthRH	Charge recovery threshold when TH pin rises (38°C)	VDD× 0.3684	VDD× 0.3847	VDD× 0.4014	V

note : ★1 The parameter is guaranteed by design.

Item	Symbol	Measurement conditions	Min.	Typ.	Max.	Units
TMRcnt pin Low-level input voltage	Vtmrl				0.5	V
TMRcnt pin High-level input voltage	Vtmrh		2			V
TMRcnt pin Low-level input current	Itmrl	TMRcnt=0V			1	μA
TMRcnt pin High-level input current	Itmrh	TMRcnt=5.0V			10	μA
LED Output pin High-level voltage	Vledh	Iled=-10mA	Vcc-0.6			V
LED Output pin leak current	Iledleak	LED=0V	-1		1	μA
Series Pass Tr On Resistance	Ron	Io=200mA		0.38	0.6	Ω
Oscillator frequency (*1)	Foc	Rosc=100kΩ	57.6	64	70.4	kHz
LED Blinking Cycle (*1)	Fled	Applied to a LED pin when Rosc=100k and in charge error mode	0.922	1.024	1.126	s
LED Blinking Duty (*1)	Dled	Applied to a LED pin when Rosc=100k	30	50	70	%
VSENSE pin discharge time (*1)	Tdischg	Foc=64kHz	58	64	70	ms
AC Adaptor connection detection time (*1, 2)	Tadp	Foc=64kHz Vpor<Vcc<Vadp Applied when Vcc=>Vadp detection	24		32	ms
	Tadp2	Applied when Vcc=<Vpor detection	32	64	96	μs
Forced charge time (*1)	Tistart	Foc=64kHz	480	512	544	ms
Forced charge OFF time (*1)	Toff	Foc=64kHz	115	128	141	ms
Battery voltage detection time (*1, 3)	Tcon	Foc=64kHz	96		128	ms
Fast charge start voltage detection time (*1, 3)	Tqstart	Foc=64kHz	96		128	ms
Charge completion current detection time (*1, 4)	Tifc	Foc=64kHz	192		256	ms
Recharge start voltage detection time (*1, 4)	Trechg	Foc=64kHz	192		256	ms
Trickle-charge timer (*1)	Tdchg	Valid when Foc=64kHz TMRcnt=Low or Open	54	60	66	min
Fast-charge timer (*1)	Tchg	Valid when Foc=64kHz TMRcnt=Low or Open	270	300	330	min
Battery overvoltage detection time (*1,3)	Tov	Foc=64kHz	96		128	ms
Charge stop temperature detection time (*1,3)	Tpro	Foc=64kHz	96		128	ms
Charge recovery temperature detection time (*1,3)						

note : *1 The parameter is guaranteed by design.

note : *2 The detection time varies depending on the timing of detection for approximately one clock due to the mode transition system operated when matched 4 times in 8ms.

note : *3 The detection time varies depending on the timing of detection for approximately one clock due to the mode transition system operated when matched 4 times in 32ms.

note : *4 The detection time varies depending on the timing of detection for approximately one clock due to the mode transition system operated when matched 4 times in 64ms.

Measuring Circuit

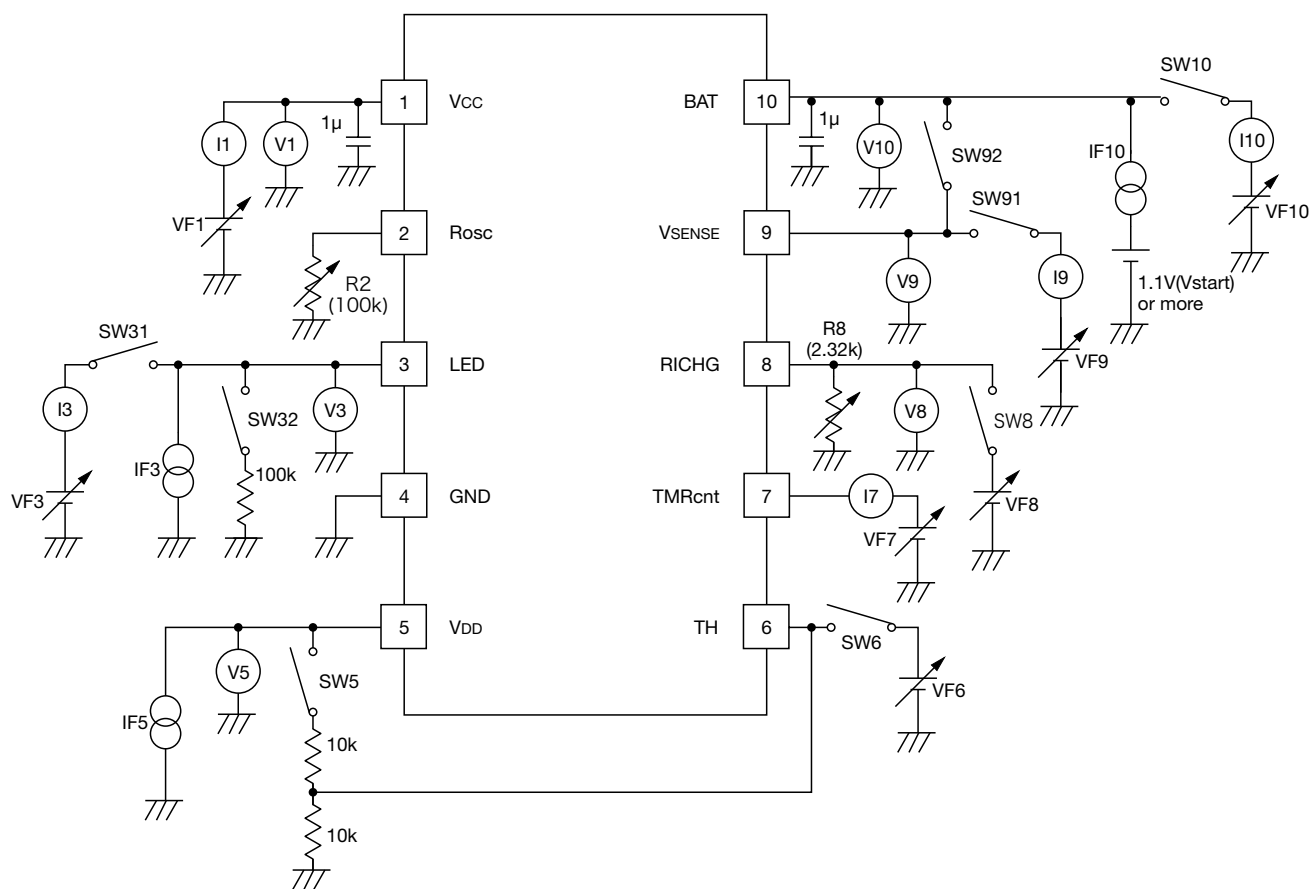

• SW setting condition

Measuring Circuit	SW31	SW32	SW5	SW6	SW8	SW91	SW92	SW10
A	×	×	○	×	×	×	○	○
B	×	×	○	×	×	○	×	○
C	×	○	○	×	×	×	○	○
D	×	○	×	○	×	×	○	○
E	○	×	○	×	×	×	○	○
F	×	○	○	×	×	×	○	×

Measurement Conditions (Except where noted otherwise Ta=0~45°C, Vcc=5V)

Item	Symbol	Measurement circuit	Measuring conditions
Supply current 1	Icc1	A	Measure the current of I1-I10 when R8=(Irapchg=500mA setting) and IF10=500mA.
Supply current 2 (*1)	Icc2	A	Measure the current of I1-I10 when R8=(Irapchg=1000mA setting) and IF10=1000mA.
Leak current 1	Ileak	A	1. Measure the current of I10 when VF1=0V and VF10=4.2V. 2. Measure the current of I10 when VF1=4.8V and VF10=4.25V (charge completion mode).
Leak current 1 (*1)	Ileak	A	1. Measure the current of I10 when VF1=0V and VF10=1.0~4.2V.
Reset detection voltage	Vpor	B	When gradually increasing VF1 from 2.3V to 2.7V under the condition of VF9=3.2V and VF10=3.2V, the VF1 when I9 exceeds 100μA should be Vpor.
Adaptor detection voltage	Vadp	C	When gradually increasing VF1 from 2.3V to 4.0V under the condition of VF10=3.2V, the VF1 when V3 changes from Low to High should be Vadp.
VSENSE pin discharge current 1	Idischg1	B	Measure the current of I9 when VF 9=4.5V to 3.2V after being kept under the condition of VF10=3.2V and VF9=4.5V and entering into error mode.
VSENSE pin discharge current 2	Idischg2	B	Measure the current of I9 immediate after increasing VF1 from 2.3V to 5.0V when VF9=3.2V and VF10=3.2V.
Charge start detection voltage	Vstart	C	When gradually increasing VF10 from 1.0V to 1.2V under the condition of VF10=0.5V, the VF10 when the charging starts (I10 >1mA) and V3=Low to High should be Vstart.
Charge start detection voltage hysteresis	Vstarthys	C	When gradually decreasing VF10 from 1.2V to 0.8V under the condition of VF10=1.5V, the VF10 when the charging stops (I10 <1mA) and V3=High to Low should be Vstart2. Vstarthys=Vstart-Vstart2
Fast-charge start detection voltage	Vqchg	A	When gradually increasing VF10 from 2.9V to 3.1V under the condition of VF10=2.5V, the VF10 when I10 exceeds 530mA should be Vqchg.
Fast-charge start detection voltage hysteresis	Vqchghys	A	When gradually decreasing VF10 from 3.1V to 2.7V under the condition of VF10=3.5V, the VF10 when I10 falls below 530mA should be Vqchg2. Vqchghys=Vqchg-Vqchg2
Recharge detection voltage	Vrechg	C	When gradually decreasing VF10 from 4.07V to 3.87V after being kept in the condition of VF10=4.25V and entering into charge completion mode, the VF10 when the charging restarts (I10 >1mA) and V3=Low to High should be Vrechg.
BAT regulation voltage	Vchg	A	Measure the voltage of V9 in fast charge mode and when IF10=-72mA (IF10 >Ifc).
Charge stop I/O potential difference 1	Vdef1	A	When gradually decreasing VF1 from 4.1V to 4.0V under the condition of fast charge mode, VF1=4.1V, and VF10=4.0V, the V1-V10 when the charging stops (I10 <1mA) should be Vdef1.
Charge stop I/O potential difference 2	Vdef2	A	When gradually increasing VF1 from 4.0V to 4.1V under the condition of fast charge mode, VF1=4.0V, and VF10=4.0V, the V1-V10 when the charging restarts (I10 >1mA) should be Vdef2.
Battery overvoltage detection voltage	Vov	C	When gradually increasing VF10 from 4.27V to 4.43V under the condition of VF10=4.25V, the VF10 when V3 becomes blinking (repeating High↔Low, charge error mode) should be Vov.

note : *1 The parameter is guaranteed by design.

• Any products mentioned in this catalog are subject to any modification in their appearance and others for improvements without prior notification.
• The details listed here are not a guarantee of the individual products at the time of ordering. When using the products, you will be asked to check their specifications.

Item	Symbol	Measurement circuit	Measuring circuit
Forced charge current	Istart	A	Measure the current of I10 immediately after increasing VF1 from 2.3V to 5.0V when VF10=3.6V and R8=2.32kΩ.
Trickle-charge current	Iprechg	A	Measure the current of I10 when VF10=2.6V and R8=2.32kΩ.
Trickle-charge current (*1)	Iprechg(*)	A	Measure the current of I10 when VF10=Vstart-Vqchg and R8 = 2.32kΩ.
Fast-charge current	Irapchg	A	Measure the current of I10 when VF10=3.6V and R8=2.32kΩ.
Fast-charge current (*1)	Irapchg(*)	A	Measure the current of I10 when VF10=Vqchg-Vchg, R8=2.32kΩ.
Fast-charge current2	Irapchg2	A	Measure the current of I10 when VF10=3.6V and R8=1.30kΩ.
Charge completion current	Ifc	B	When gradually increasing VF9 from 4.1V to 4.2V under the condition of VF9=3.6V and VF10=Vqchg, the I10 immediately before V3=High to Low and the charging stops (I10 >1mA) should be Ifc.
Charge completion current (*1)	Ifc(*)	B	When gradually increasing VF9 from 4.1V to 4.2V under the condition of VF9=3.6V and VF10>Vqchg, the I10 immediately before V3=High to Low and the charging stops (I10 <1mA) should be Ifc.
Chip temperature detection 1 (*1)	Ttreg1	A	When gradually increasing chip temperature from 83°C to 103°C under the condition of fast charge mode, VF1=5V, and VF10=4V, the chip temperature when I10 drops to the value that is 1C (I10 when chip temperature is 25°C)× 95% should be Ttreg1.
Chip temperature detection 2 (*1)	Ttreg2	A	When gradually increasing chip temperature from 85°C to 120°C under the condition of fast charge mode, VF1=5V, and VF10=4V, the chip temperature when I10 drops to the value that is 0.2C (I10 when chip temperature is 125°C)×105% should be Ttreg2.
Chip temperature detection difference (*1)	Tdtreg	A	Tdtreg=Ttreg2 -Ttreg1
Thermal shutdown temperature (*1)	Tsd	C	When gradually increasing chip temperature from 143°C to 163°C under the condition of fast charge mode, VF1=5V, and VF10=4V, the chip temperature when V3 becomes blinking (repeating High↔Low, charge error mode) and the charging stops (I10 < 1mA) should be Tsd.
Temperature detecting reference voltage	VDD	D	Measure the voltage of V5 when VF6=1.0V and VF10=3.6V.
Temperature detecting reference terminal current (*1)	IDD	D	When gradually decreasing IF5 under the condition of VF6=1.0V and VF10=3.6V, the IF5 when V5=VDD×90% should be IDD.
Charge stop temperature detection voltage (Low temperature)	VthSL	D	When gradually increasing VF6 from 1.0V to 2.0V under the condition of fast charge mode, VF6=1.0V, and VF10=3.6V, the VF6 when V3=High to Low and the charging stops (I10 <1mA) should be VthSL.
Charge stop temperature detection voltage (High temperature)	VthSH	D	When gradually decreasing VF6 from 1.0V to 0V under the condition of fast charge mode, VF6=1.0V, and VF10=3.6V, the VF6 when V3=High to Low and the charging stops (I10 <1mA) should be VthSH.
Charge recovery temperature detection voltage (Low temperature)	VthRL	D	When gradually decreasing VF6 from 2.0V to 1.0V under the condition of charge stop temperature detection mode, VF6=2.0V, and VF10=3.6V, the VF6 when V3=Low to High and the charging restarts (I10 >1mA) should be VthRL.

note : *1 The parameter is guaranteed by design.

Item	Symbol	Measurement circuit	Measuring circuit
Charge recovery temperature detection voltage (high temperature)	VthRH	D	When gradually increasing VF6 from 0V to 1.0V under the condition of charge stop temperature detection mode, VF6=0V, and VF10=3.6V, the VF6 when V3=Low to High and the charging restarts ($ I_{I0} > 1\text{mA}$) should be VthRH.
TMRcnt pin Low-level input voltage	Vtmrl	C	When gradually decreasing from 5.0V to 0V under the condition of fast charge mode, time reduction mode (See Pin description), VF7=5.0V, and VF10=3.6V, the voltage below V3 should be Vtmrl and the voltage exceeding V3 should be VtmrH when V3 becomes blinking (repeating High↔Low, charge error mode) and the charging stops ($ I_{I0} < 1\text{mA}$).
TMRcnt pin High-level input voltage	Vtmrh		
TMRcnt pin Low-level input current	Itmrl	A	Measure the current of I7 under the condition of fast charge mode, VF7=0V, and VF10=3.6V.
TMRcnt pin High-level input current	Itmrh	A	Measure the current of I7 under the condition of fast charge mode, VF7=5V, and VF10=3.6V.
LED output pin High-level voltage	Vledh	A	Measure the voltage of V3 under the condition of fast charge mode, IF3=-10mA, and VF10=3.6V.
LED output pin leak current	Iledleak	E	Measure the current of I3 when VF3=0V and VF10=4.25V (charge completion mode).
Series pass Tr On resistance	Ron	A	Measure the voltage of V1-V10 under the condition of fast charge mode, VF1=4.0V, and IF10= -200mA. Ron=(V1-V10)/200mA
LED Blinking Cycle (*1)	Fled	C	Measure the blinking cycle (repeating High↔Low) of V3 after being kept under the condition of VF10=4.5V and entering charge error mode.
LED Blinking Duty (*1)	Dled	C	Measure the duty ratio of blinking cycle (repeating High↔Low) Fled of V3 after being kept in the condition of VF10=4.5V and entering charge error mode.
VSENSE pin discharge time (*1)	Tdischg	B	When increasing VF1 from 2.3V to 5.0V under the condition of VF9=3.6V and VF10=3.6V, measure the time from when VF1>2.5V (Vpor) to when the current of I9 drops below 100μA.
AC Adaptor connection detection time (*1)	Tadp	C	1. After being kept for 128ms and more (more than Tpro) under the condition of VF10=3.6V and VF1=2.3V to 3.6V, measure the time from when VF1>3.8V (Vadp) to when V3=Low to High when increasing VF1 from 3.6V to 5.0V. 2. When decreasing VF10 from 5.0V to 3.6V under the condition of fast charge mode and VF10=3.2V, measure the time from when VF1<3.8V (Vadp) to when the fast charge stops ($ I_{I0} < 1\text{mA}$).
	Tadp2	C	When decreasing VF1 from 5.0V to 2.0V in fast charge mode and when VF10=3.6V, measure the time from when VF1<2.5V (Vpor) to when V3=High to Low.

note : *1 The parameter is guaranteed by design.

Item	Symbol	Measurement circuit	Measuring circuit
Forced charge time (*1)	Tistart	C	When increasing VF1 from 2.3V to 5.0V under the condition of VF10=3.6V, measure the time from forced charge start(I10 >1mA) to forced charge stop(I10 <1mA).
Forced charge OFF time (*1)	Toff	C	After increasing VF1 from 2.3V to 5.0V under the condition of VF10=3.6V, the half time from forced charge stop(I10 <1mA) to fast charge start(I10 >1mA) should be Toff.
Battery voltage detection time (*1)	Tcon	C	When decreasing VF10 from 4.25V to 3.8V after charge complete mode under the condition of VF10=4.25V, the half time from when the current of I9 exceeds 100μA to when V3=Low to High and the charging restarts(I10 >1mA) should be Tcon.
Fast charge start voltage detection time (*1)	Tqstart	C	When increasing VF10 from 2.6V to 3.6V under the condition of trickle charge mode, VF10=2.6V, and R8=2.32kΩ, measure the time from when VF10>3.0V(Vqchg) to when fast charge starts(I10 >530mA).
Charge completion current detection time (*1)	Tifc	F	When decreasing IF10 from -80mA to -30mA under the condition of fast charge mode and R8=2.32kΩ, measure the time from when IF10>-56mA(Iifc) to when the charging stops (I10>-1mA).
Recharge start voltage detection time (*1)	Trechg	C	When decreasing VF10 from 4.25V to 3.8V after charge completion mode under the condition of VF10=4.25V, measure the time from when VF10<3.97V(Vrechg) to when the current of I9 exceeds 100μA.
Trickle-charge timer (*1)	Tdchg	C	When decreasing VF7 from 5.0V to 0V under the condition of trickle charge mode, VF7=5.0V, VF10=2.6V, and time reduction mode(See Pin description), measure the time from when VF10<0.5V (Vtmr) to when V3 starts blinking(V3=High to Low, charge error mode) and the charging stops(I10 <1mA). Tdchg=Tdchg2×2.304E + 08/109 in time reduction mode due to a TH pin.
Fast-charge timer (*1)	Tchg	C	When decreasing VF7 from 5.0V to 0V under the condition of fast charge mode, VF7=5.0V, VF10=3.6V, and time reduction mode(See Pin description), measure Tchg2 that is the time from when VF10<0.5V(Vtmr) to when V3 starts blinking(V3=High to Low, charge error mode) and the charging stops (I10 <1mA). Tchg=Tchg2×1.152E + 09/137 in time reduction mode due to a TH pin.
Battery overvoltage detection time (*1)	Tov	C	When increasing VF10 from 3.6V to 4.5V under the condition of fast charge mode and VF10=3.6V, measure the time from when VF10>4.35V(Vov) to when V3 starts blinking (V3=High to Low, charge error mode).
Charge stop temperature detection time (*1)	Tpro	C	When increasing(decreasing) VF6 from 1.0V to 2.0V(0V) under the condition of fast charge mode, VF6=1.0V, and VF10=3.6V, measure the time from when VF6>VthSL(VF6<VthSH) to when V3=High to Low and the charging stops(I10 <1mA).
Charge recovery temperature detection time (*1)	Tpro	C	When decreasing (increasing) VF6 from 2.0V(0V) to 1.0V under the condition of charge stop detection mode, VF6=2.0V(0V), and VF10=3.6V, measure the time from when VF6<VthRL(VF6>VthRH) to when V3=Low to High and the charging restarts (I10 >1mA).

note : *1 The parameter is guaranteed by design.

Timing Chart

(*All typ. numeric value)

Normal charge

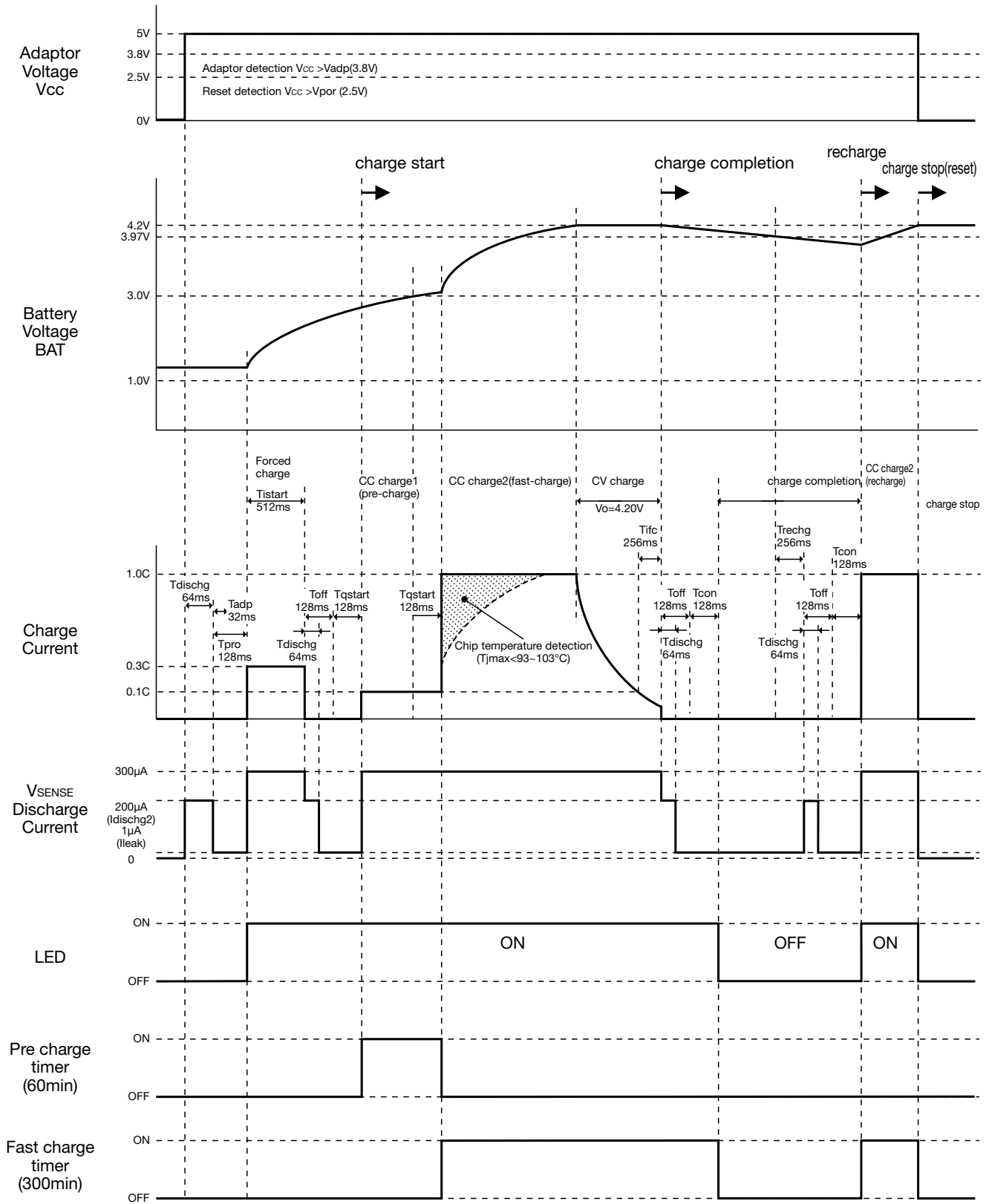

• Any products mentioned in this catalog are subject to any modification in their appearance and others for improvements without prior notification.
 • The details listed here are not a guarantee of the individual products at the time of ordering. When using the products, you will be asked to check their specifications.

Input Adaptor

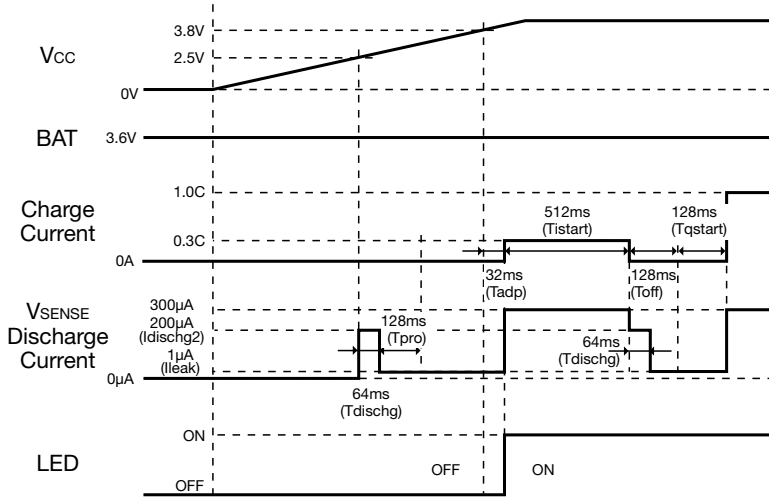

Release Adaptor

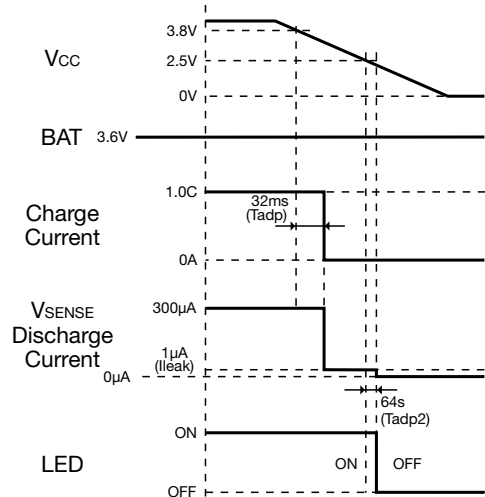

1.1V < BAT < 3.0V, Charge start (trickle charge)

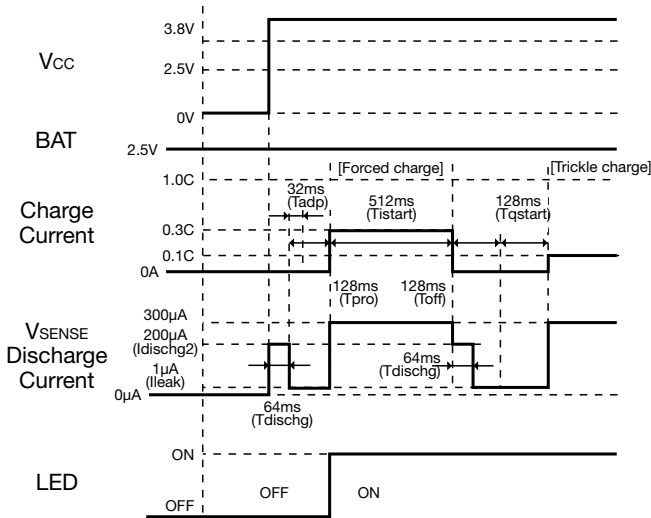

Trickle charge timeout

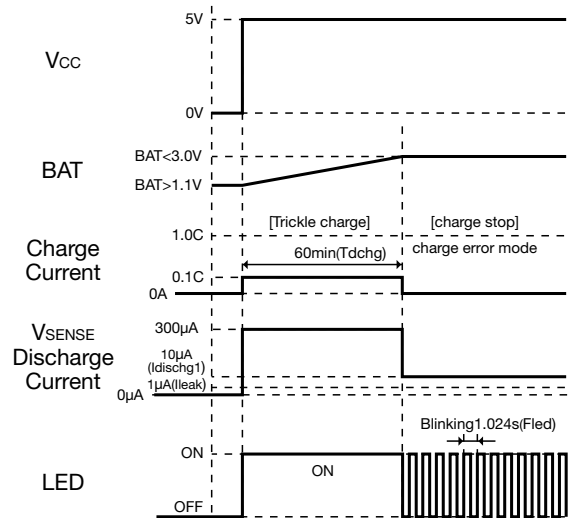

3.0V < BAT < 4.2V, Charge start (fast charge)

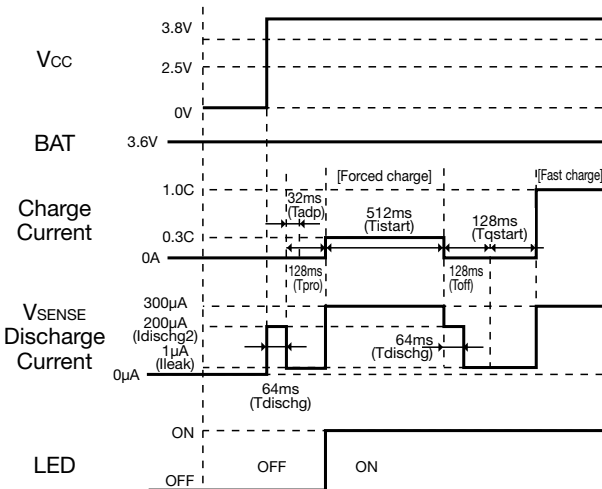

Fast charge timeout

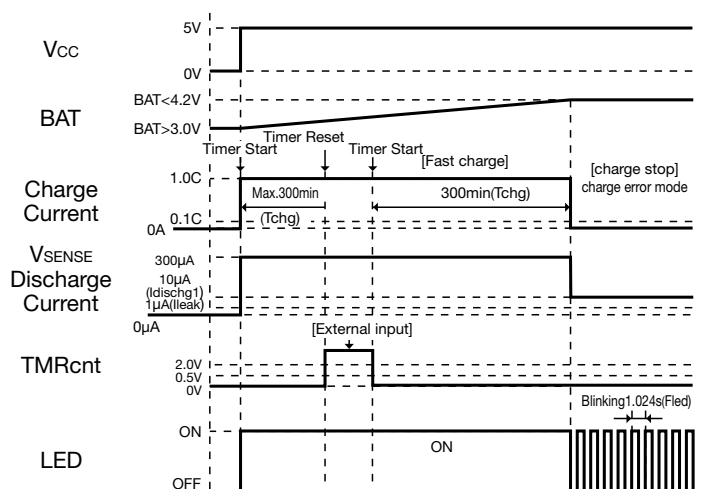

• Any products mentioned in this catalog are subject to any modification in their appearance and others for improvements without prior notification.
 • The details listed here are not a guarantee of the individual products at the time of ordering. When using the products, you will be asked to check their specifications.

BAT < 1.1V, Charge start (Battery unconnection) **BAT > 4.35V, Charge start (battery overvoltage)**

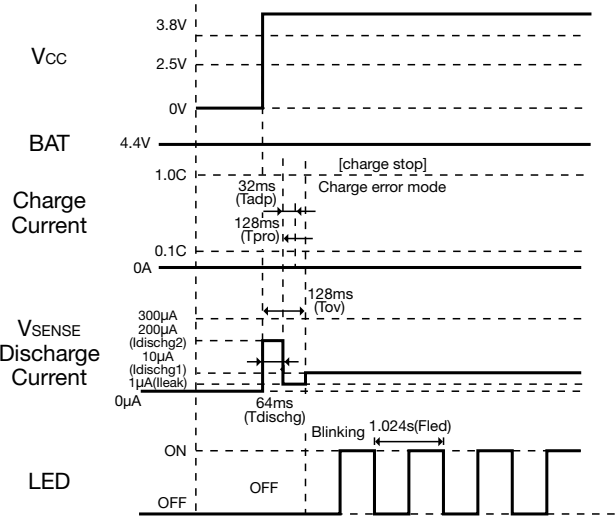
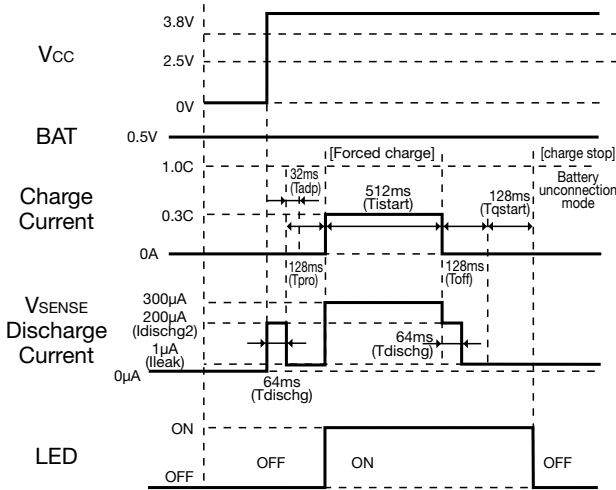

BAT = 4.2V, Charge start (charge completion)

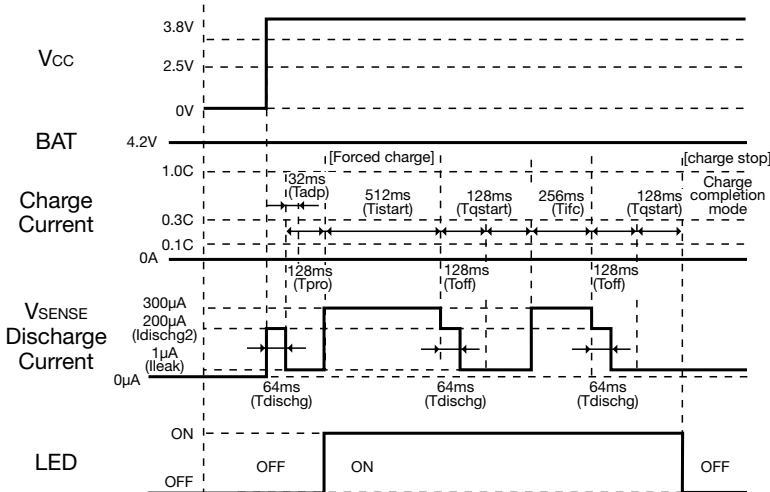

Full charge detection

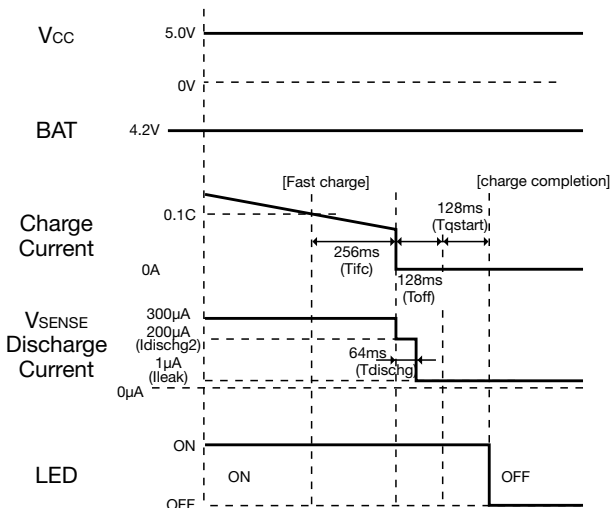

Recharge detection

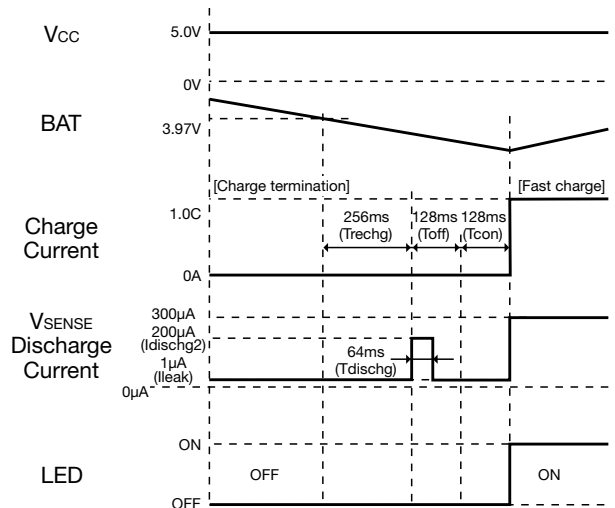

• Any products mentioned in this catalog are subject to any modification in their appearance and others for improvements without prior notification.
 • The details listed here are not a guarantee of the individual products at the time of ordering. When using the products, you will be asked to check their specifications.

Fast-charge start voltage detection

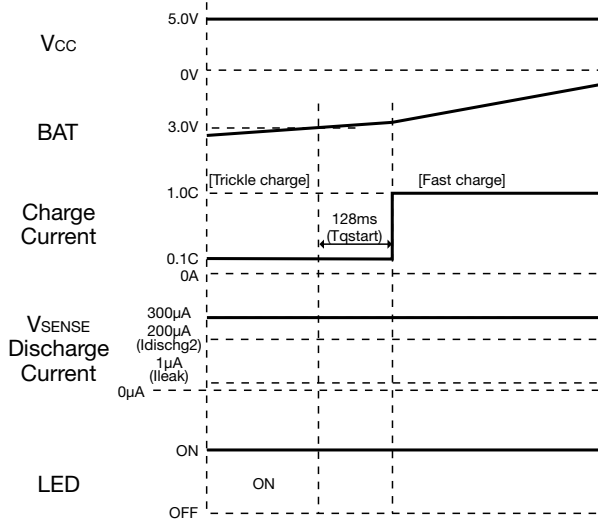

Chip temperature detection

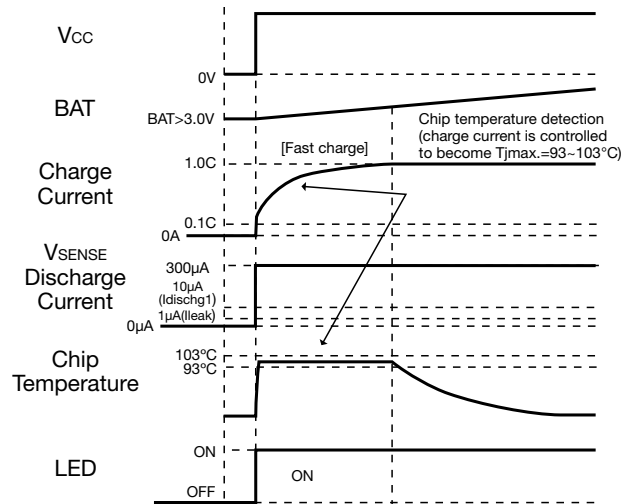

Thermal shutdown

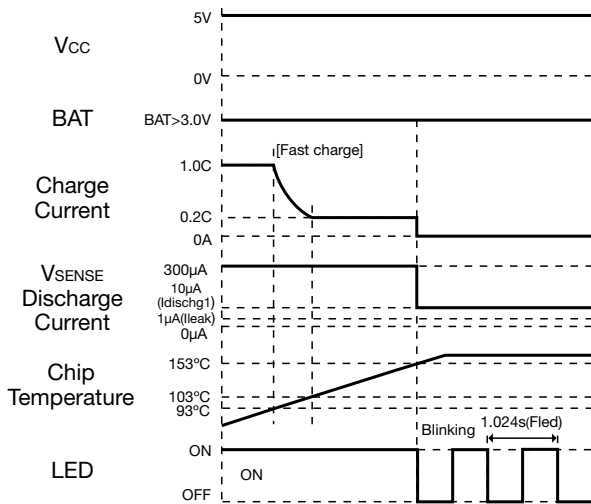

Battery temperature detection

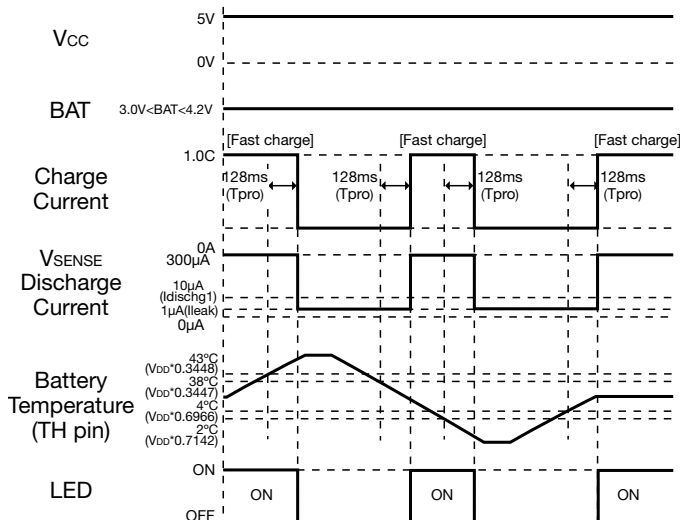

Characteristics (Except where noted otherwise $V_{CC}=5.0V$, $R_{ICHG}=2.32k\Omega$, $R_{OSC}=100k\Omega$, $T_a=25^\circ C$)

Charge current - BAT voltage

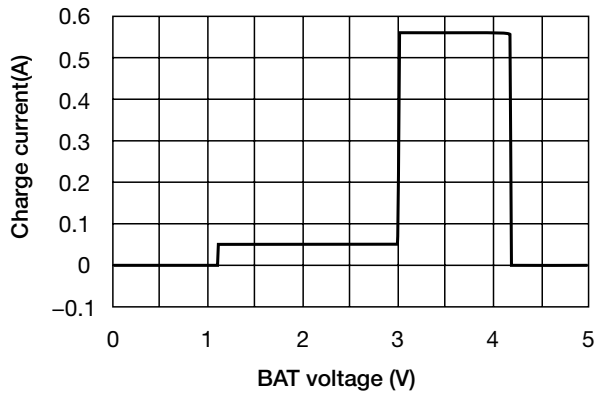

RICHG voltage - Charge current

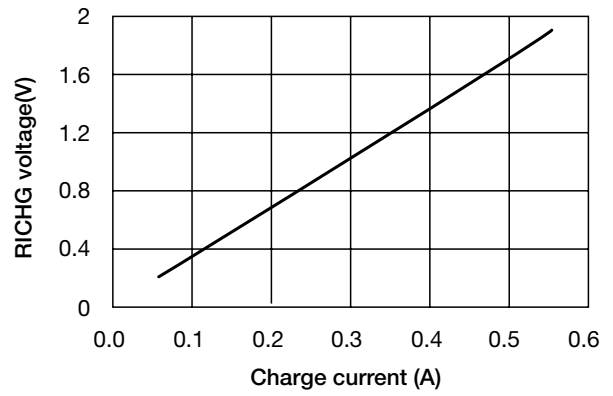

Supply current - V_{CC} (BAT=4.0V, Charge OFF)

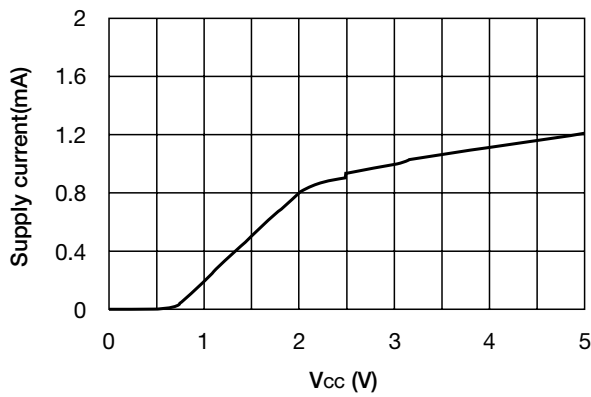

V_{SENSE} current - V_{CC} (BAT=4.0V, Charge OFF)

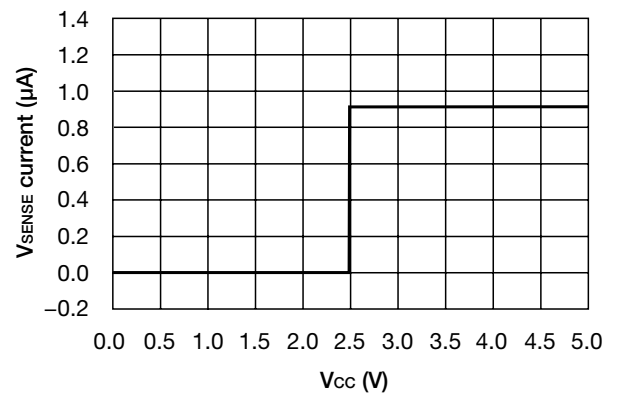

Charge current - RICHG external resistor

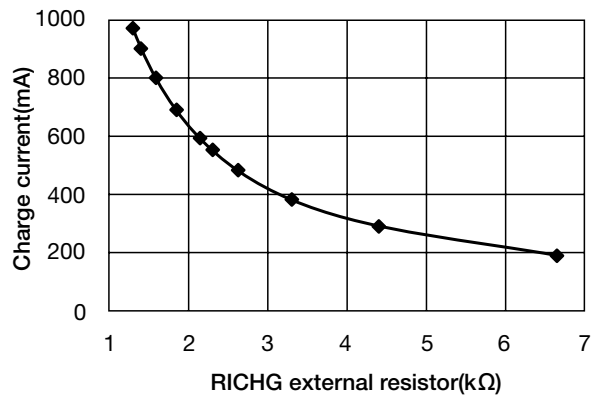

Foc - R_{OSC} external resistor

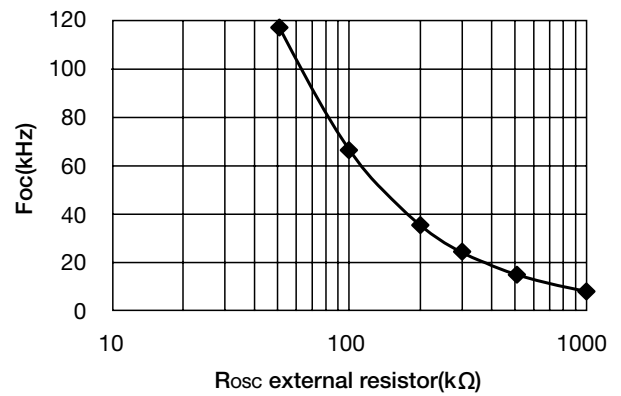

Note : * These are typical characteristics.

Line Regulation

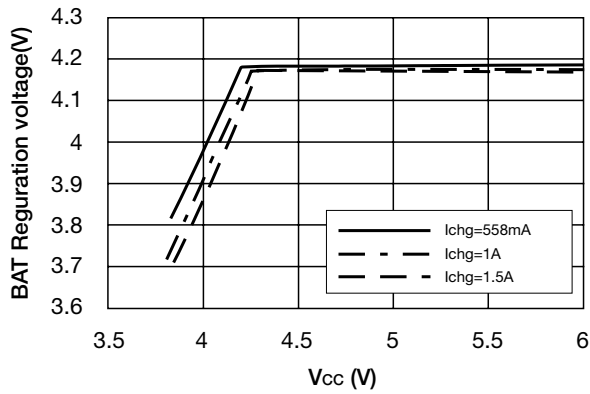

Load Regulation

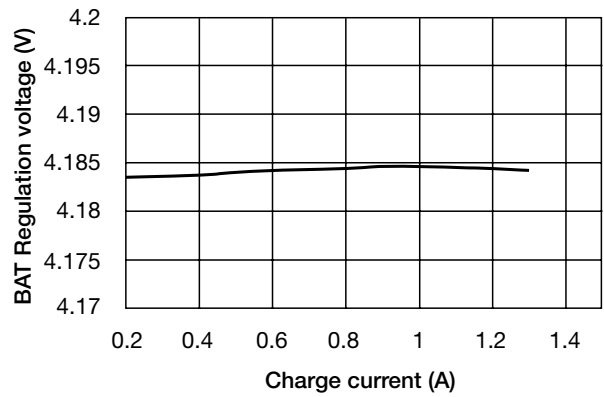

Battery Charge characteristics

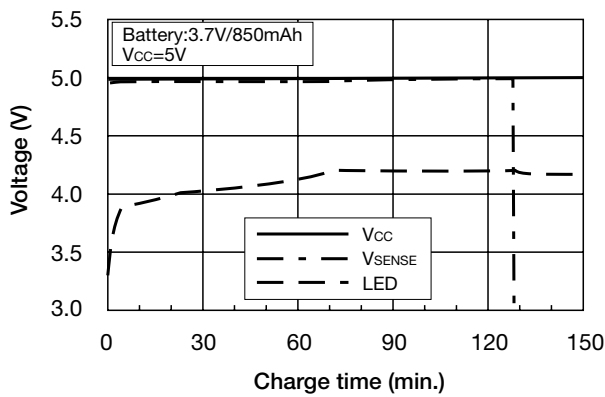

Battery Charge characteristics

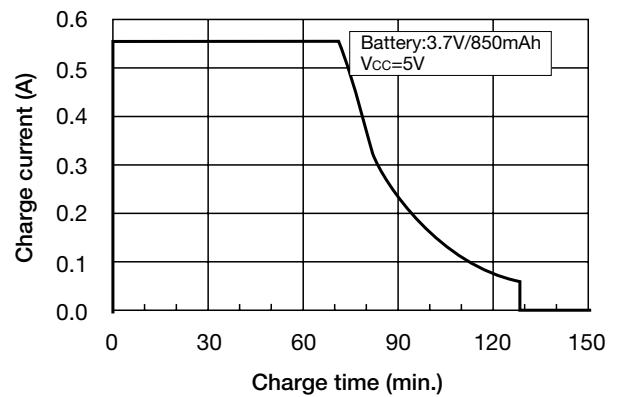

Chip Temperature Control · Thermal Shutdown

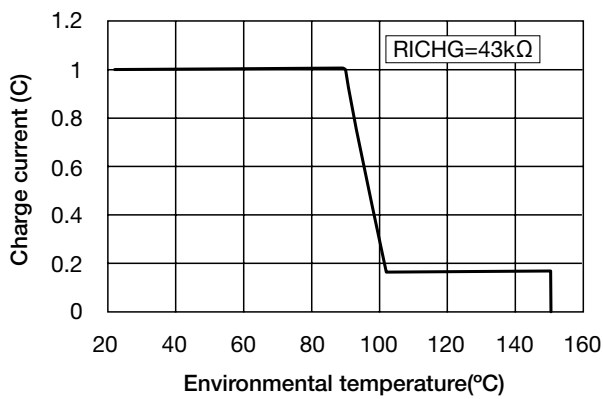

Series Pass Tr On Resistance - Charge current

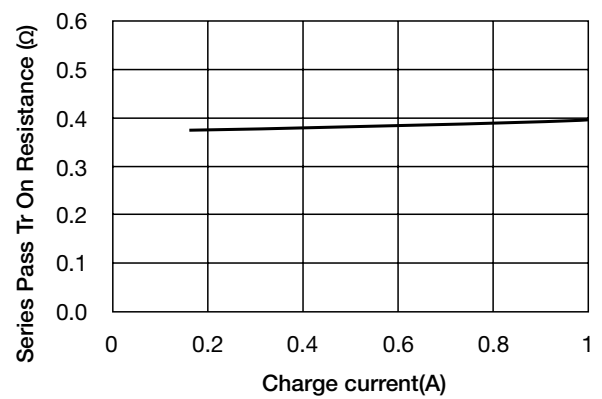

note : * These are typical characteristics.

Temperature Dependency

Supply current 1

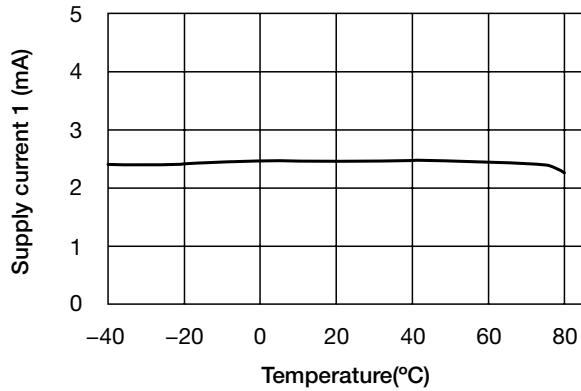

Supply current 2

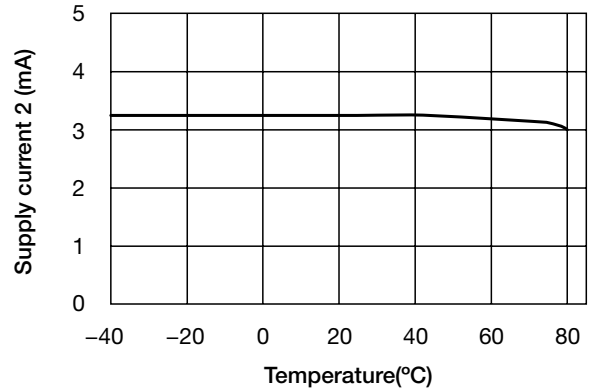

Leak current 1-1

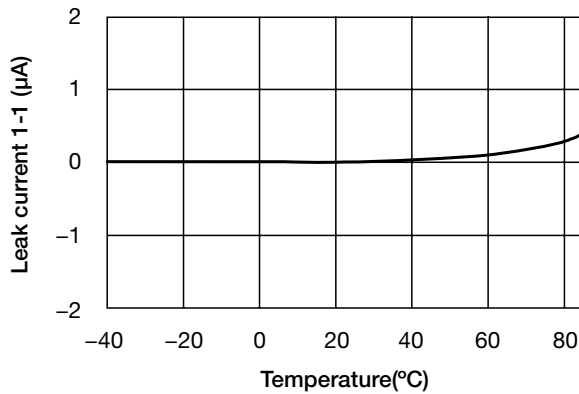

Leak current 1-2

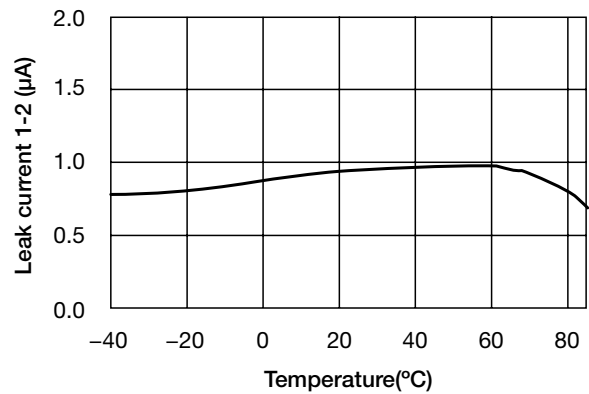

Reset detection voltage

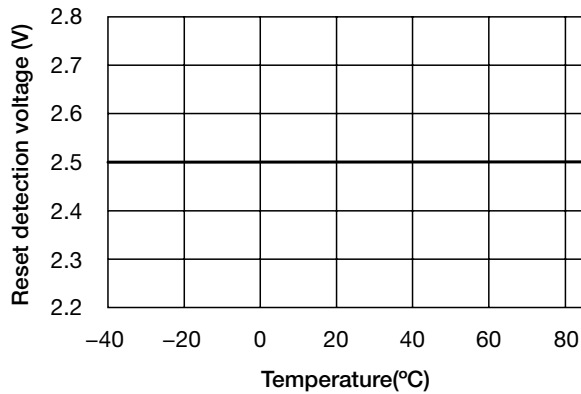

Adaptor detection voltage

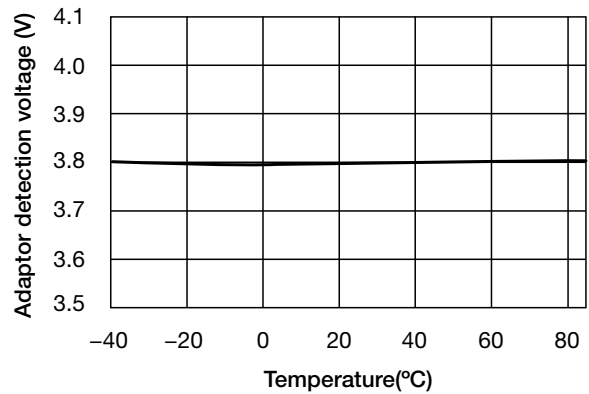

Note : * These are typical characteristics.

V_{SENSE} pin Discharge current 1

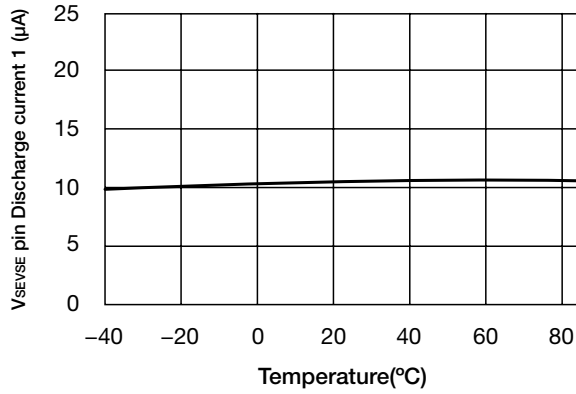

V_{SENSE} pin Discharge current 2

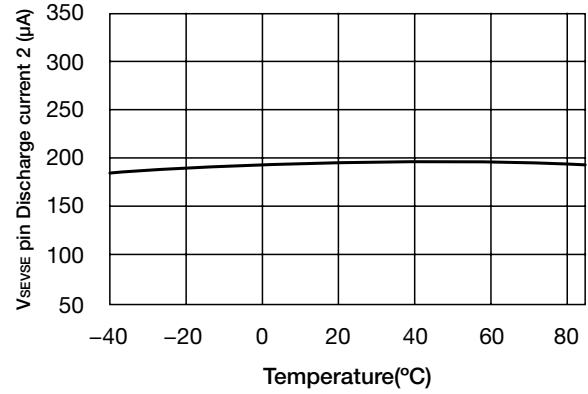

Charge Start detection voltage

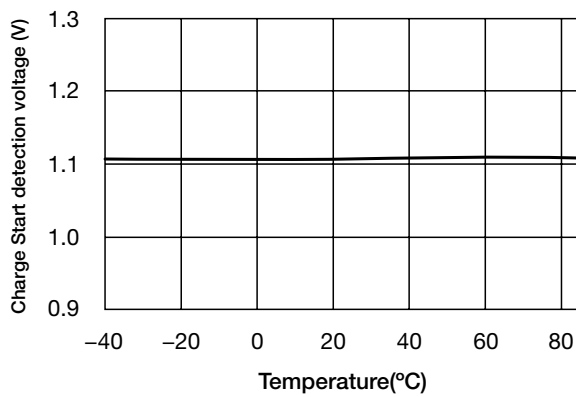

Charge Start detection voltage hysteresis

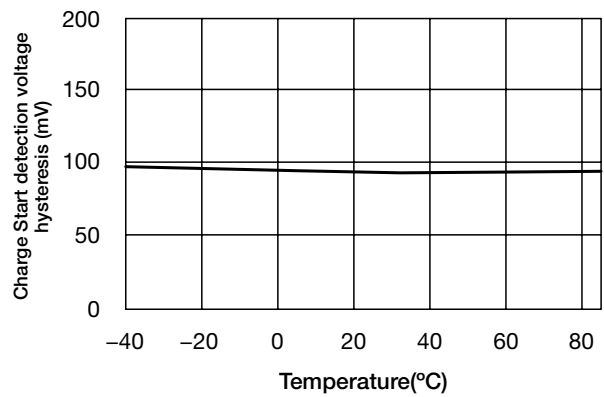

Fast-charge Start detection voltage

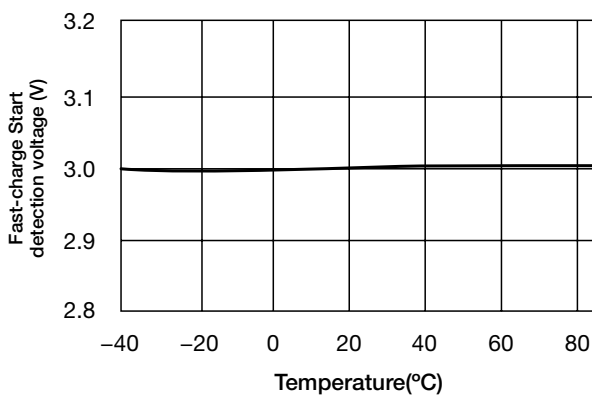

Fast-charge Start detection voltage hysteresis

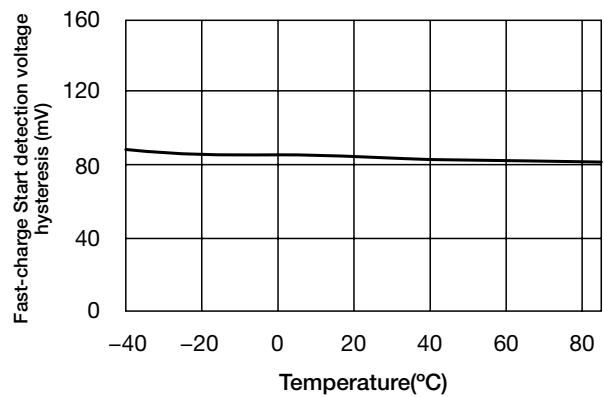

Note : * These are typical characteristics.

■ Recharge detection voltage

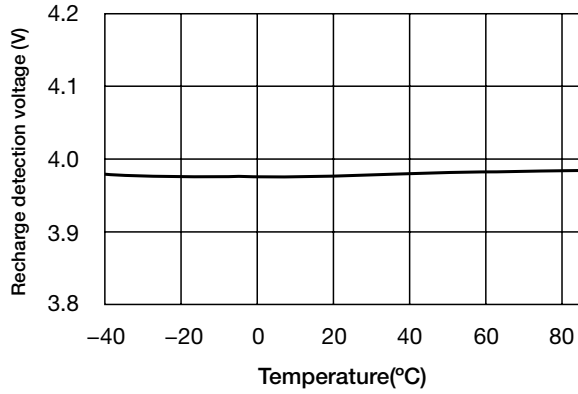

■ BAT Regulation voltage

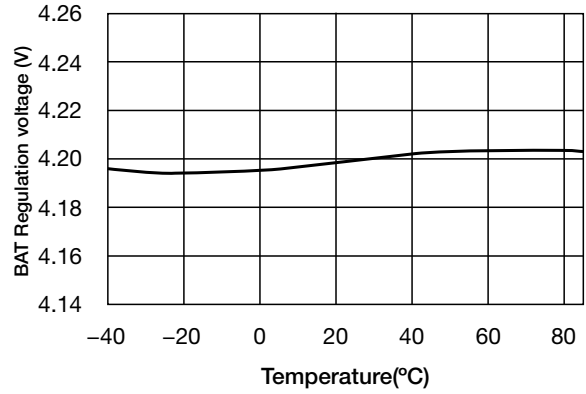

■ Charge Stop I/O Potential Difference 1

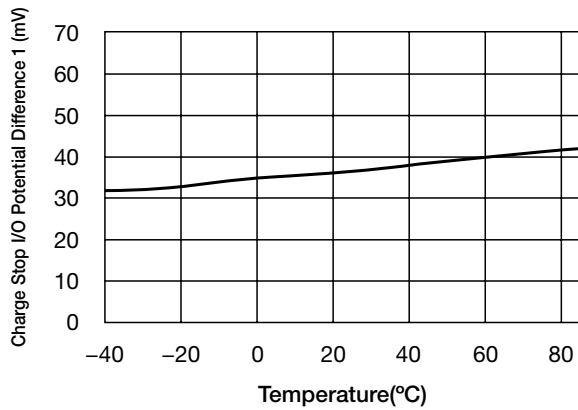

■ Charge Stop I/O Potential Difference 2

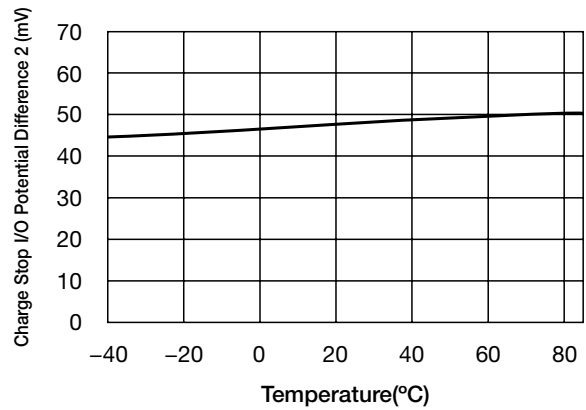

■ Battery Overvoltage detection voltage

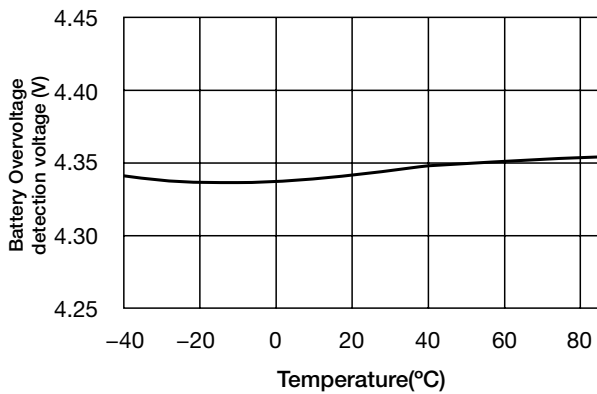

■ Forced Charge Current

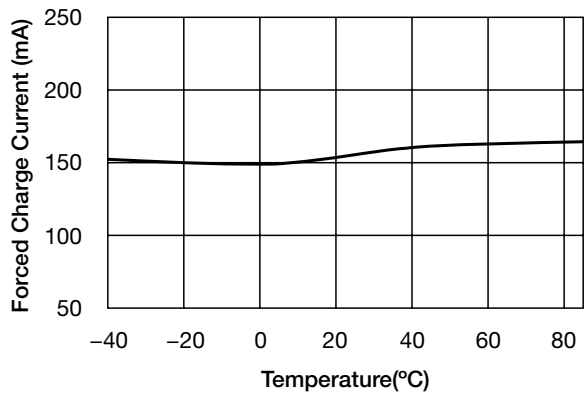

Note : * These are typical characteristics.

Trickle-charge current

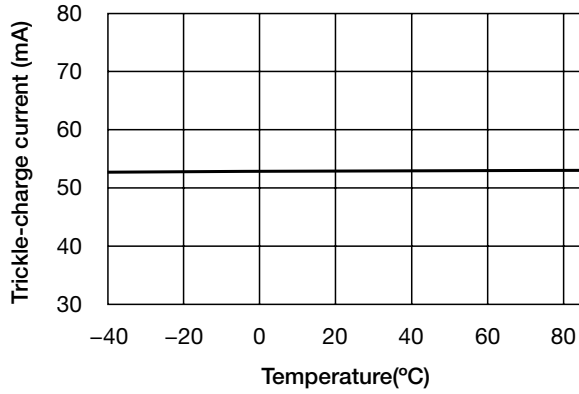

Fast-charge current

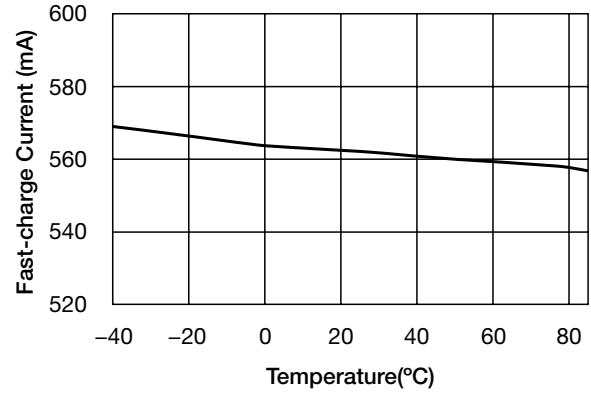

Charge Completion current

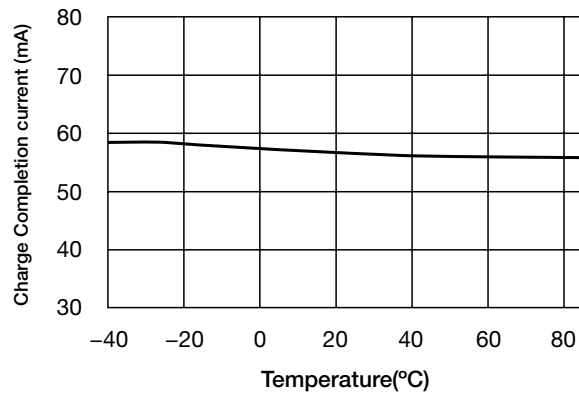

Temperature Detecting Reference Voltage

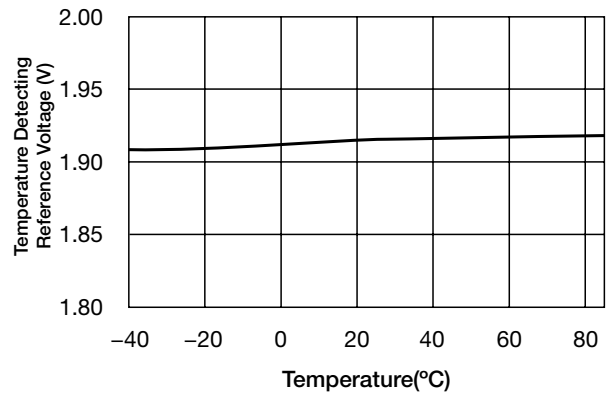

Charge Stop Temperature Detection Voltage (low temp.)

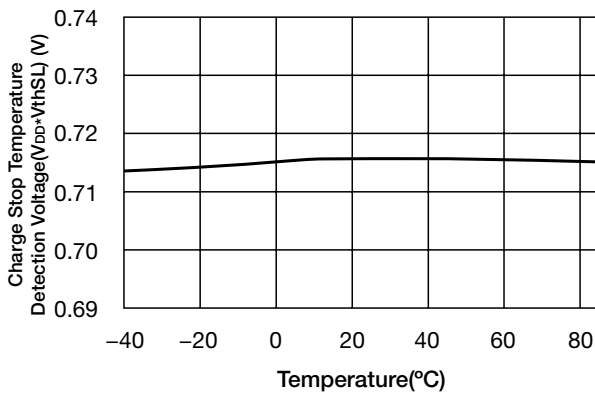

Charge Stop Temperature Detection Voltage (high temp.)

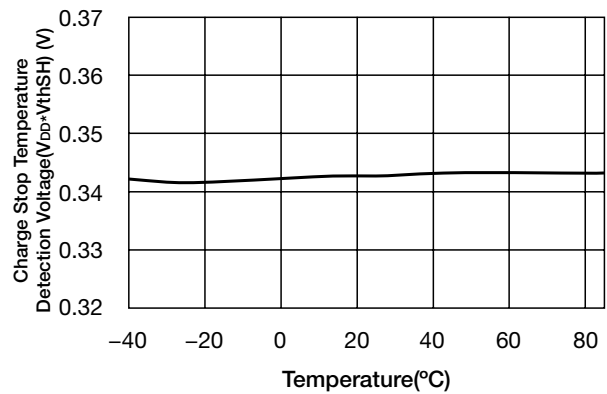

Note : * These are typical characteristics.

■ Charge Recovery Temperature Detection Voltage (Low temp.)

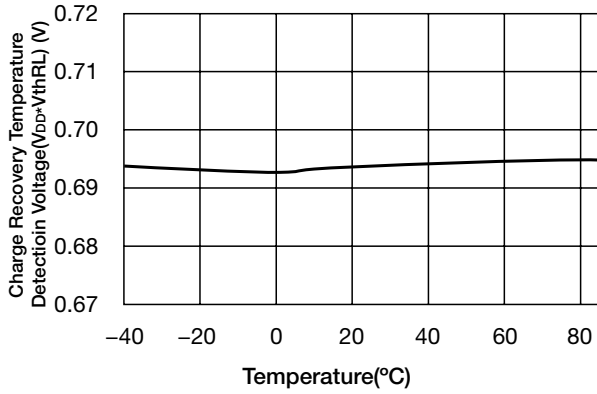

■ Charge Recovery Temperature Detection Voltage (High temp.)

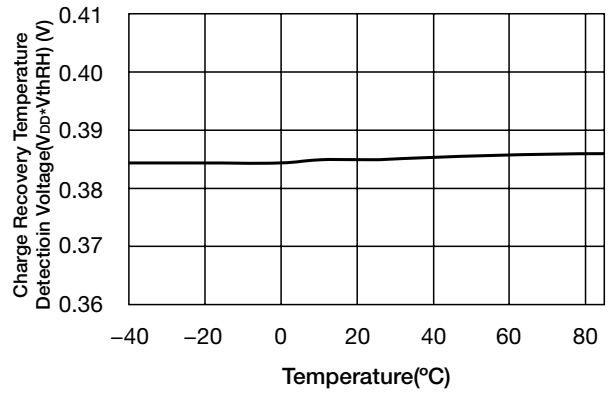

■ TMRcnt pin Low-level input current

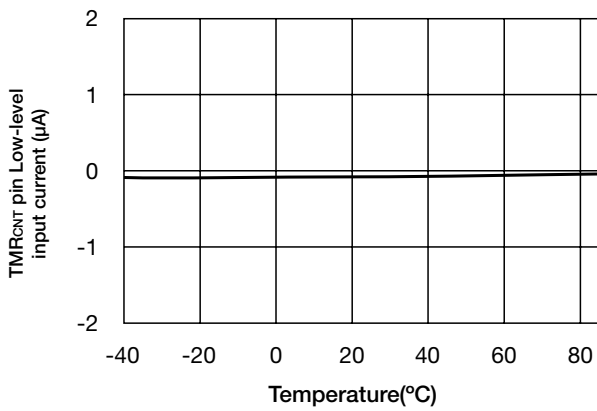

■ TMRcnt pin High-level input current

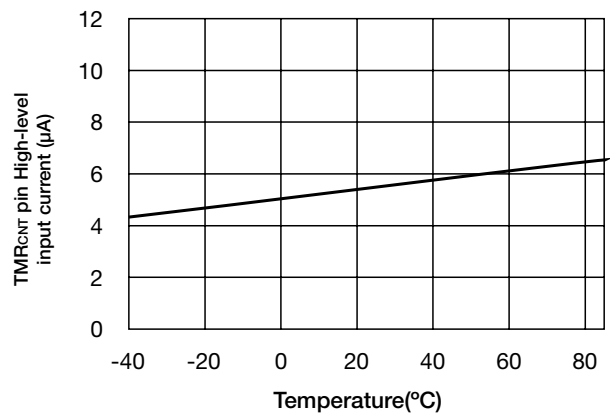

■ LED Output pin High-level voltage

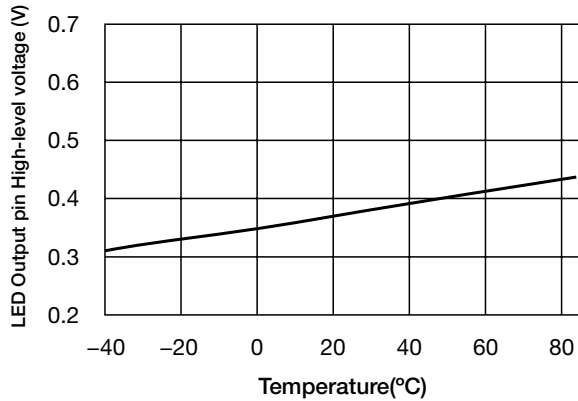

■ LED Output pin Leak current

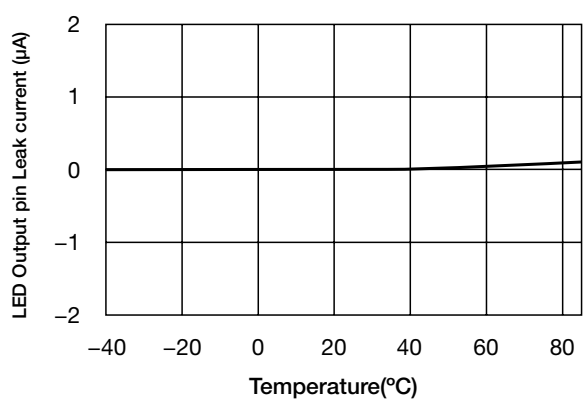

Note : * These are typical characteristics.

Series Pass Tr On Resistance

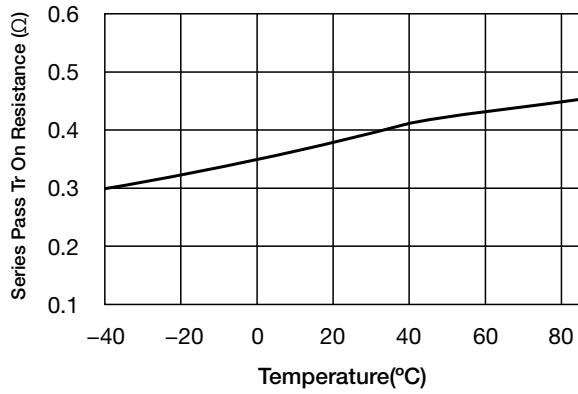

LED Blinking cycle

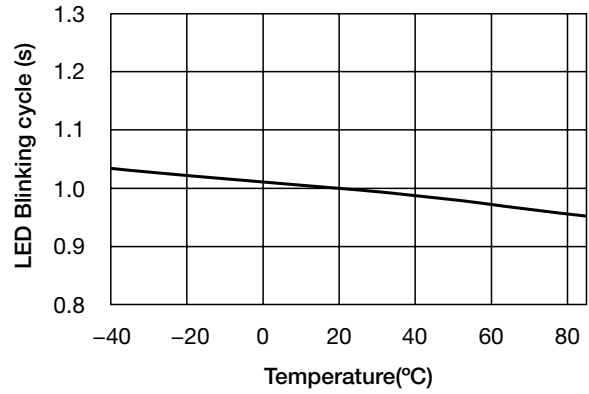

V_{SENSE} Pin Discharge Time

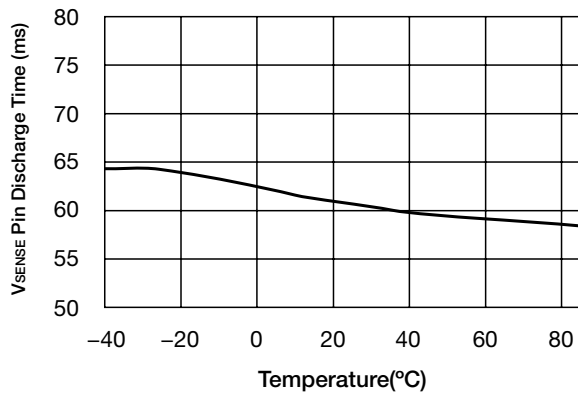

Forced Charge Time

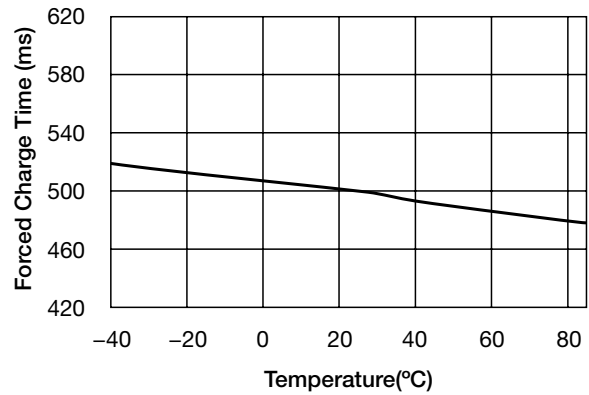

Forced Charge OFF Time

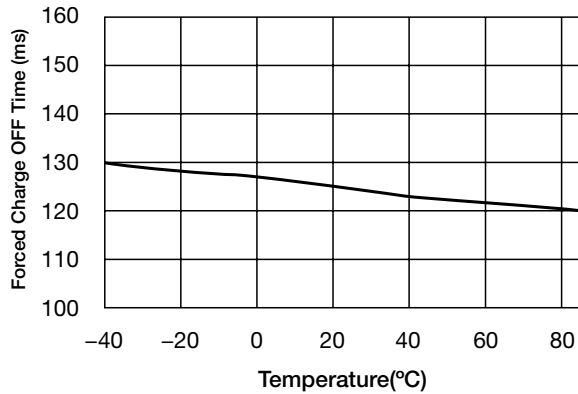

Trickle-charge Timer

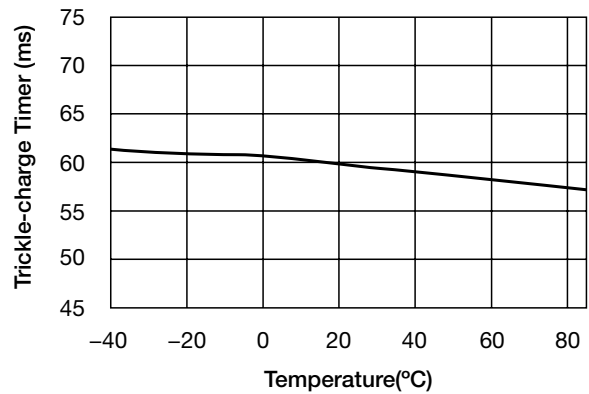

Note : * These are typical characteristics.

■ Fast-charge Timer

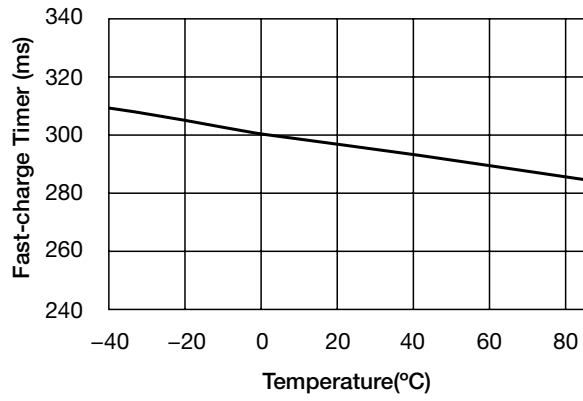

Note : * These are typical characteristics.

Application Circuit

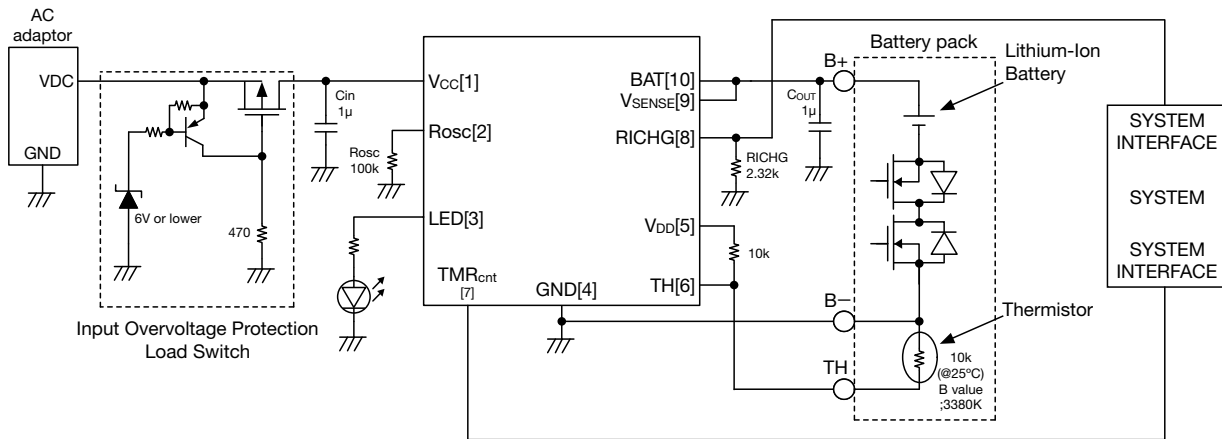

- We shall not be liable for any trouble or damage caused by using this circuit.
- In the event a problem which may affect industrial property or any other rights of us or a third party is encountered during the use of information described in these circuit, Mitsumi Electric Co., Ltd. shall not be liable for any such problem, nor grant.