

1 to 4cells Lithium-ion/Lithium-polymer battery secondary protection IC

MM3508A Series

Outline

MM3508A series is a double protection IC for 1 to 4 serial cells lithium-ion / lithium-polymer rechargeable battery for secondary protection IC. It detects battery voltage for each cell.

The FUSE cutting signal is the output between period of time. And the CELL voltage is released by electric discharge after FUSE was cut.

Features

(Unless otherwise specified, Topr=+25°C)

- Range and accuracy of overcharge detection/hysteresis voltage
 - Overcharge detection voltage 4.0V to 4.5V, 5mV step Accuracy±20mV (Topr=0 to +50°C)
 - Overcharge hysteresis voltage 50mV to 500mV, 50mV step Accuracy±20%
- Range of detection delay time
 - Overcharge detection delay time 1ms to $(1ms \times 2^{n1}) + (1ms \times 2^{n2})$
*n1 and n2 can select two arbitrary integers between 0 to 13. (However n1≠n2)
- Low current consumption
 - Typ. 3.5µA, Max. 5.0µA (Vcell=4.0V)
 - Typ. 0.15µA, Max. 0.30µA (Vcell=2.3V)
- Absolute maximum ratings
 - VDD pin VSS-0.3 to VSS+28V
 - OV pin VSS-0.3V to VDD+0.3V
 - Storage temperature -55 to +125°C
 - Operation temperature -40 to +110°C
- The FUSE cutting signal is the output between period of time. And the CELL voltage is released by electric discharge resistance of "60KΩ" after FUSE was cut.
And CELL stops an electric discharge if the CELL voltage becomes less than the electric discharge release voltage.

Pin Assignment

Top view SOT-26A	Pin No.	Function
	1	The input terminal of the positive voltage of V2 cell and the negative voltage of V3 cell
	2	The input terminal of the positive voltage of V3 cell and the negative voltage of V4 cell
	3	The input terminal of the power supply of IC and the positive voltage of V4 cell
	4	Output of over charge detection (Output type is CMOS)
	5	The input terminal of the ground of IC and the negative voltage of V1 cell
	6	The input terminal of the positive voltage of V1 cell and the negative voltage of V2 cell

Top view SSON-6A	Pin No.	Function
	1	The input terminal of the power supply of IC and the positive voltage of V4 cell
	2	The input terminal of the positive voltage of V3 cell and the negative voltage of V4 cell
	3	The input terminal of the positive voltage of V2 cell and the negative voltage of V3 cell
	4	The input terminal of the positive voltage of V1 cell and the negative voltage of V2 cell
	5	The input terminal of the ground of IC and the negative voltage of V1 cell
	6	Output of over charge detection (Output type is CMOS)

1 to 3cell Li-ion/Li-polymer battery Secondary protection IC MM3508C Series

Outline

MM3508C series is a double protection IC for 2-4 cell Li batteries.
It detects battery voltage for each cell.
The terminal CT is used to control the output voltage of the terminal OV.

Features (Unless otherwise specified, Topr=+25°C)

- Range and accuracy of overcharge detection/hysteresis voltage
 - Overcharge detection voltage 4.0V to 4.5V, 5mV step Accuracy±20mV (Topr=0 to +50°C)
 - Overcharge hysteresis voltage 50mV to 500mV, 50mV step Accuracy±20%
- Range of detection delay time
 - Overcharge detection delay time 1ms to $(1\text{ms} \times 2^{n1}) + (1\text{ms} \times 2^{n2})$
*n1 and n2 can select two arbitrary integers between 0 to 13. (However n1≠n2)
- Low current consumption
 - Typ. 3.0μA, Max. 5.0μA (Vcell=4.0V)
 - Typ. 2.5μA, Max. 4.0μA (Vcell=2.3V)
- Absolute maximum ratings
 - VDD pin VSS-0.3 to VSS+28V
 - OV pin VSS-0.3V to VDD+0.3V
 - Storage temperature -55 to +125°C
 - Operation temperature -40 to +110°C
- The terminal CT is used to control the output voltage of the terminal OV.

Pin Assignment

Top view SOT-26A	Pin No.	Function
	1	The input terminal of the positive voltage of V1 cell and the negative voltage of V2 cell
	2	The input terminal of the positive voltage of V2 cell and the negative voltage of V3 cell
	3	The input terminal of the power supply of IC and the positive voltage of V4 cell
	4	Output of over charge detection (Output type is CMOS)
	5	The input terminal of the ground of IC and the negative voltage of V1 cell
	6	The input terminal of OV output control signal

Top view SSON-6A	Pin No.	Function
	1	The input terminal of the power supply of IC and the positive voltage of V4 cell
	2	The input terminal of the positive voltage of V2 cell and the negative voltage of V3 cell
	3	The input terminal of the positive voltage of V1 cell and the negative voltage of V2 cell
	4	The input terminal of OV output control signal
	5	The input terminal of the ground of IC and the negative voltage of V1 cell
	6	Output of over charge detection (Output type is CMOS)

• Any products mentioned in this catalog are subject to any modification in their appearance and others for improvements without prior notification.
• The details listed here are not a guarantee of the individual products at the time of ordering. When using the products, you will be asked to check their specifications.

Selection Guide (3000pcs/Reel)

Product name	Package	Function	Overcharge detection voltage [V]	Overcharge hysteresis voltage[mV]	Overcharge detection dead time [s]	Output type	Latch function	Stand by function
			V _{CELLU}	V _{HYS}	T _{OV}			
MM3508A01RRE	SSON-6A	1 to 4 cells	4.220±0.02	500±100	4.10±0.9	CMOS Output Active High	○	○
MM3508A02RRE	SSON-6A	1 to 4 cells	4.350±0.02	500±100	4.10±0.9		○	○
MM3508A03RRE	SSON-6A	1 to 4 cells	4.450±0.02	500±100	4.10±0.9		○	○
MM3508B01RRE	SSON-6A	1 to 4 cells	4.350±0.02	500±100	5.00±1.5		-	○
MM3508C01RRE	SSON-6A	1 to 3 cells	4.350±0.02	390±160	4.00±1.2		-	-
MM3508C01NRH	SOT-26A	1 to 3 cells	4.350±0.02	390±160	4.00±1.2		-	-
MM3508C02NRH	SOT-26A	1 to 3 cells	4.350±0.02	390±160	5.65±1.7		-	-

Please inquire to us, if you request a rank other than the above.

Application Circuit

· MM3508A, B Series (When using it for 4 cells)

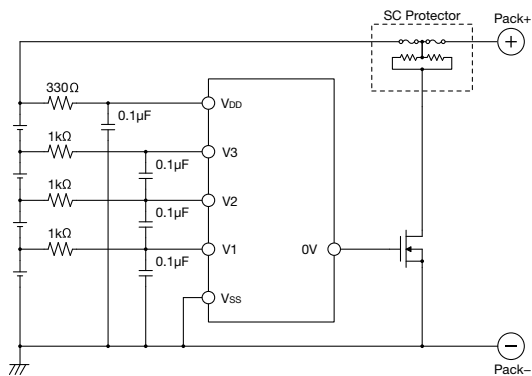

· MM3508C Series (When using it for 3 cells)

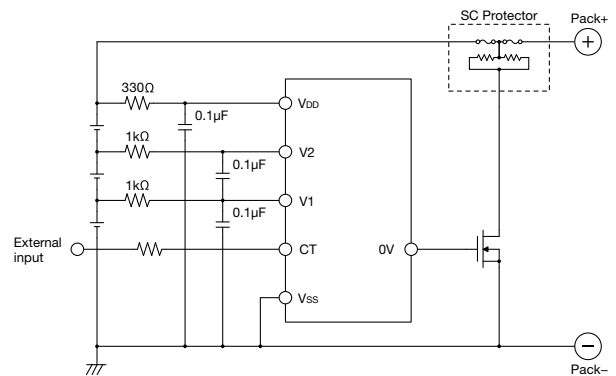

• Any products mentioned in this catalog are subject to any modification in their appearance and others for improvements without prior notification.
 • The details listed here are not a guarantee of the individual products at the time of ordering. When using the products, you will be asked to check their specifications.