

Selection Guide (3000pcs/Reel)

| Product name | Package | Function | Overcharge detection voltage [V] | Overcharge hysteresis voltage[mV] | Overcharge detection dead time [s] | Output type |
|--------------|---------|--------------|----------------------------------|------------------------------------|------------------------------------|----------------------------|
| | | | V _{CELLU} | V _{HYS} | T _{ov} | |
| MM3284ANREH | SOT-26A | 1 to 4 cells | 4.350±0.030 | 200±60 | 1.2 | CMOS Output Active High |
| MM3284CNREH | SOT-26A | 1 to 4 cells | 4.350±0.030 | 1000±200 | 10 | |
| MM3284CRRE | SSON-6A | 1 to 4 cells | 4.350±0.030 | 1000±200 | 10 | |
| MM3284ENREH | SOT-26A | 1 to 4 cells | 4.450±0.030 | 200±60 | 1.2 | |
| MM3284FNREH | SOT-26A | 1 to 4 cells | 4.350±0.030 | V4 : 680±100 V3 to V1 : 340±100 | 1.2 | |
| MM3284GRRE | SSON-6A | 1 to 4 cells | 4.450±0.030 | 1000±200 | 10 | |
| MM3284HNREH | SOT-26A | 1 to 4 cells | 4.350±0.030 | 1000±200 | 5.0 | |
| MM3284INREH | SOT-26A | 1 to 4 cells | 4.450±0.030 | 1000±200 | 5.0 | |
| MM3284JRRE | SSON-6A | 1 to 4 cells | 4.400±0.030 | 1000±200 | 10 | |
| MM3284MRRE | SSON-6A | 1 to 4 cells | 4.280±0.030 | 1000±200 | 4.1 | |
| MM3284NNREH | SOT-26A | 1 to 4 cells | 4.450±0.030 | 200±60 | 4.1 | |
| MM3284PNREH | SOT-26A | 1 to 4 cells | 4.300±0.030 | V4 : 620±100 V3 to V1 : 270±100 | 2.0 | |
| MM3284RNREH | SOT-26A | 1 to 4 cells | 4.450±0.030 | V4 : 750±100 V3 to V1 : 420±100 | 2.0 | |
| MM3284TRRE | SSON-6A | 1 to 4 cells | 4.220±0.030 | 1000±200 | 10 | |
| MM3284URRE | SSON-6A | 1 to 4 cells | 4.220±0.030 | 200±60 | 0.1 | |

Please inquire to us, if you request a rank other than the above.

Application Circuit

(1) When using it for 4 cells

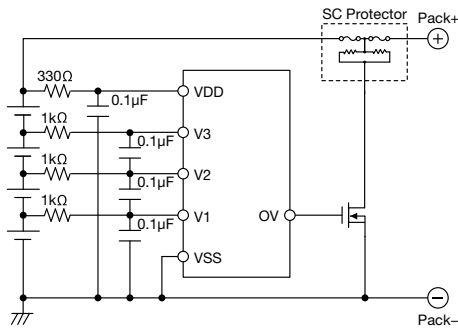

(2) When using it for 3 cells

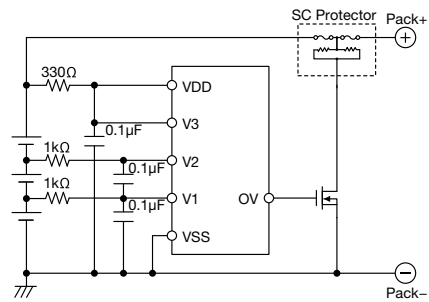
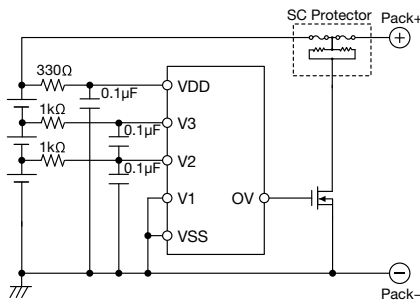

(3) When using it for 2 cells

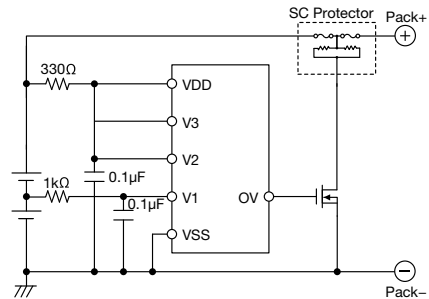
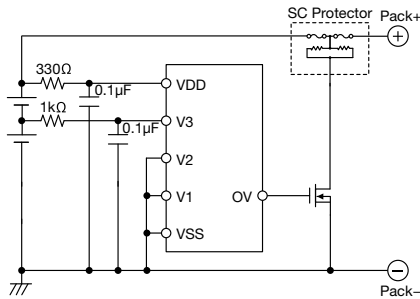

(4) When using it for 1 cell

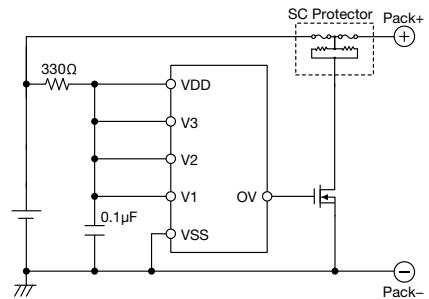
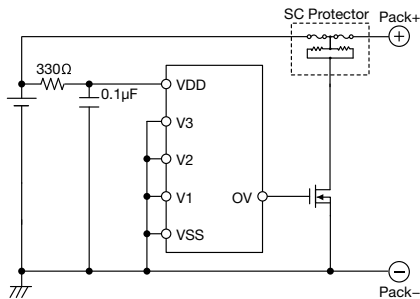

• Any products mentioned in this catalog are subject to any modification in their appearance and others for improvements without prior notification.
 • The details listed here are not a guarantee of the individual products at the time of ordering. When using the products, you will be asked to check their specifications.