

White LED Driver ICs

Monolithic IC MM3120

Outline

This IC is a white LED driver IC. It is a step-up DC-DC converter IC designed to drive up to 4 LEDs with constant current and suitable for backlight drivers. It requires fewer external component count using the small packages, SON-8A and WLCSP-8B, and is ideal for small battery-powered applications.

Features

1. Enables to drive up to 4 white LEDs in a series connection
2. Input voltage range 2.7 to 5.5V
3. Shutdown current 0.1 μ A typ.
4. High efficiency 82% typ.
5. Luminance control PWM system
6. Includes a Schottky diode and switching transistors
7. Incorporates a soft start circuit
8. Incorporates a current limit circuit
9. Incorporates an output open protection circuit

Package

SON-8A

Applications

1. Cell phones
2. Digital video cameras
3. Digital still cameras
4. Portable game devices
5. PDA

Block Diagram

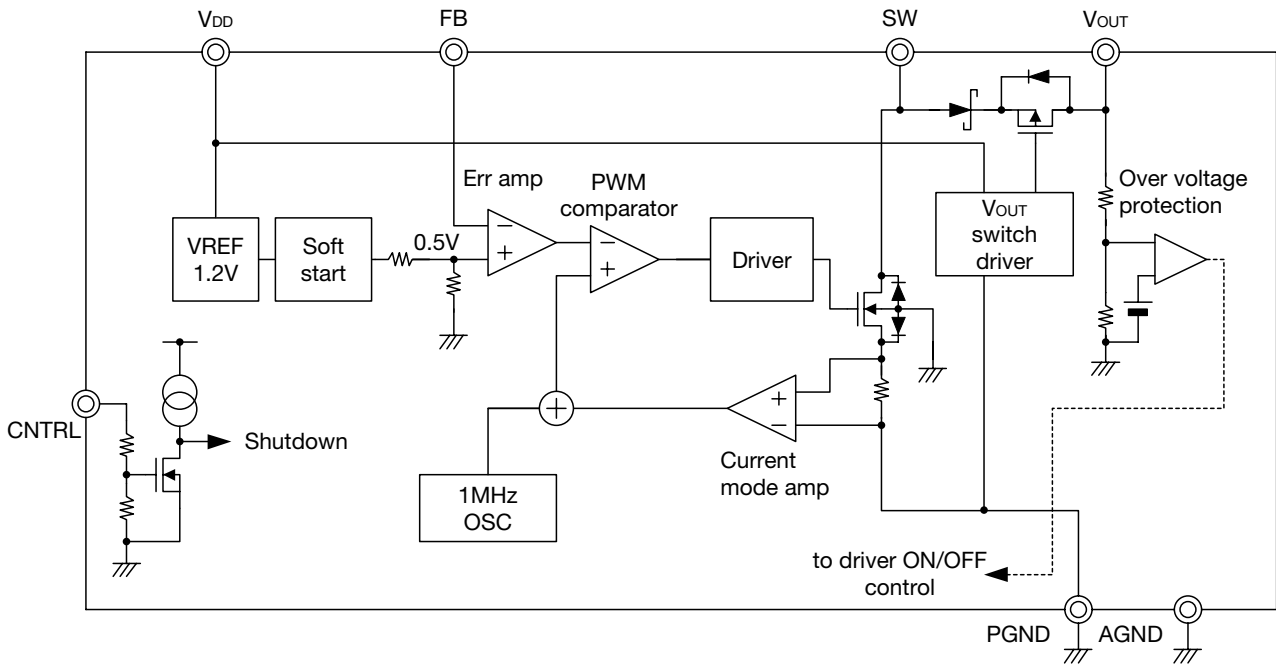

Pin Assignment

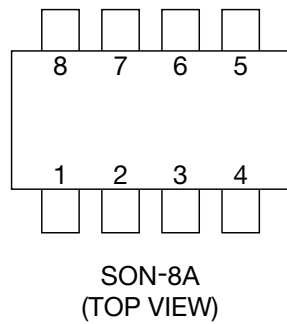

1	V _{DD}
2	AGND
3	CNTRL
4	FB
5	PGND
6	N. C.
7	SW
8	V _{OUT}

Pin Description

Pin No.	Pin name	Function
1	V _{DD}	Input V supply pin
2	AGND	Analog ground pin
3	CNTRL	Control pin for ON/OFF
4	FB	Feedback pin
5	PGND	Power ground pin
6	N. C.	No connect
7	SW	Power switched pin
8	V _{OUT}	Power output pin

Absolute Maximum Ratings (Ta=25°C)

Item	Symbol	Ratings	Units
Storage temperature	T _{STG}	-65~+150	°C
Operating temperature	T _{OPR}	-30~+85	°C
Input voltage	V _{DD}	-0.3~7	V
SW voltage	V _{SW}	-0.3~22	V
V _{OUT} voltage	V _{OUT}	-0.3~22	V
FB voltage	V _{FB}	-0.3~V _{DD} +0.3	V
CNTRL voltage	V _{CNTRL}	-0.3~V _{DD} +0.3	V
Allowable loss *1	P _d	300	mW

note1: *1 Absolute Maximum Ratings are those values beyond which the life of the device may be impaired.

Recommended Operating Conditions (Ta=25°C)

Item	Symbol	Ratings	Units
Operating voltage	V _{OP}	2.7~5.5	V
Operating temperature	T _{OP}	-10~+60	°C

Electrical Characteristics (Except where noted otherwise TA=25°C, VDD=3.7V, VCNTRL=3.7V)

Item	Symbol	Measurement conditions	Min.	Typ.	Max.	Units	Measuring Circuit Condition	
Minimum operating voltage	VDDL		2.7			V		
Maximum operating voltage	VDDH				5.5	V		
Feedback voltage	VFB	Voltage over external resistor	Ta=+25°C	0.475	0.500	0.525	V	1-A
			Ta=-10~+60°C	0.465	0.500	0.535		
FB pin bias current	IFB	VFB=0.5V *2 Ta=-10~+60°C			200	nA	2-A	
Supply current	IDD, ON	CNTRL="High"		1.5	2.0	mA	2-A	
	IDD, OFF	CNTRL=0V		0.1	0.5	µA		
	IDD, ON_t	CNTRL="High" Ta=-10~+60°C			2.8	mA		
	IDD, OFF_t	CNTRL=0V Ta=-10~+60°C			1.0	µA		
Switching frequency	fOSC		Ta=+25°C	750	1000	1250	kHz	1-A
			Ta=-10~+60°C	650	1000	1350		
Maximum duty cycle	DMAX	Ta=-10~+60°C VSW=3.7V	85	90		%	2-B	
Switch Tr current limit	ILIMIT	*1		320	400	mA	1-C	
Switch Tr VSWL	VSWL	ISW=250mA *1		0.35		V	1-D	
Switch Tr leakage current	ISWLEAK	CNTRL=0V, VSW=5.5V, VOUT=0V	Ta=+25°C		0.01	1	µA	2-C
			Ta=-10~+60°C		0.01	10		
SW_VOUT drop voltage	VSD	IOUT=20mA *1		0.6		V	1-A	
CNTRL voltage high	VCNTH	Ta=-10~+60°C	1.2		VDD+0.3	V	1-A	
CNTRL voltage low	VCNTL	Ta=-10~+60°C	-0.3		0.3	V	1-A	
CNTRL pin bias current	ICNT	Ta=-10~+60°C	4	9	20	µA	2-A	
PWM dimming control frequency		using the CNTRL pin			500	Hz	1-A	
Efficiency		VDD=3.7V, IOUT=20mA		82		%	1-A	
Open circuit protection voltage	VOVP	LED removed.	18	20	22	V	1-B	
Maximum output power	POMAX	*1	500			mW	1-D	
Start-up time	tSTART	VOUT=90% steady state		150		µs	1-A	
Quiescent LED current	ILEDOFF	CNTRL=0V, VDD=4.2V, VSW=4.2V, VOUT=0V	Ta=+25°C		0.1	µA	2-C	
			Ta=-10~+60°C		0.5			

note1: *1 This parameter is guaranteed by design.

note2: *2 FB Pin Bias Current flows out of the pin.

note3: *3 The MM3120 is guaranteed to meet specifications from -10°C ~ 60°C by design.

Specifications over the -30 to 85°C operating temperature range are assured by design, characterization and correlation with statistical process controls.

Measuring Circuit

Measuring Circuit 1

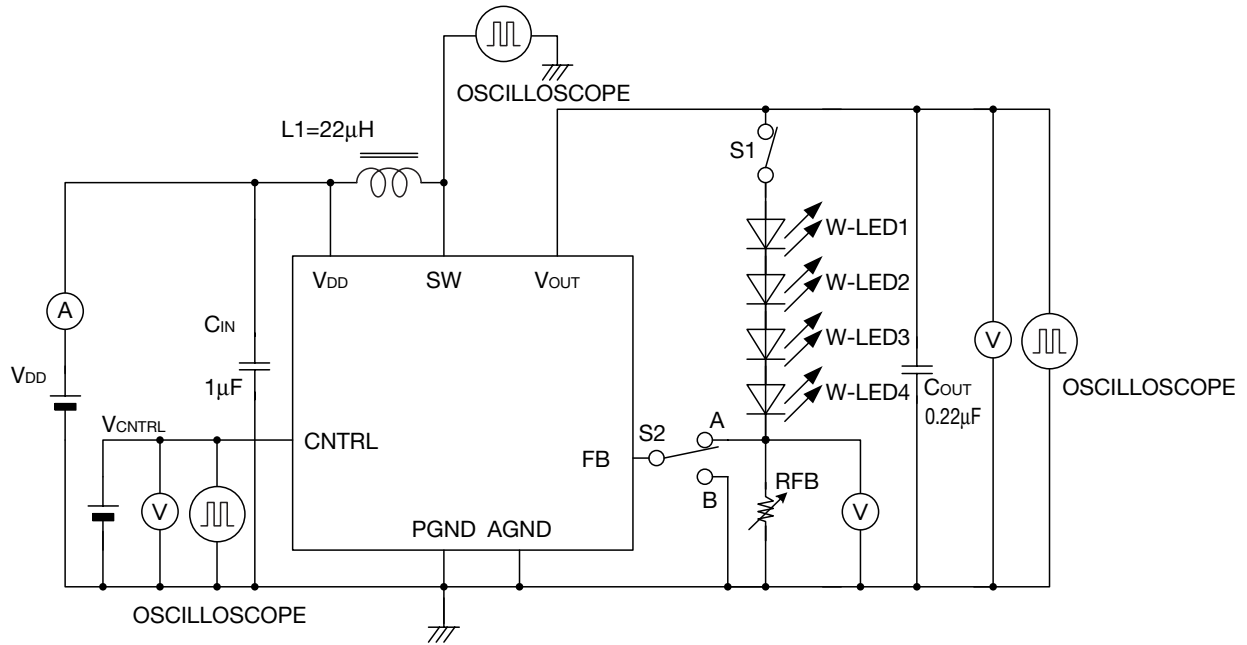

S (n) conditions

	S1	S2	RFB
1-A	on	A	25Ω
1-B	off	A	25Ω
1-C	on	B	25Ω
1-D	on	A	variable

Inductor: C3-Y1.5R (MITSUMI) 22µH, DCR=0.66Ω max.
 Capacitor: Ceramic Capacitor (Panasonic) 0.22µF/X7R
 W-LED: NSCW215 (NICHIA)

Measuring Circuit 2

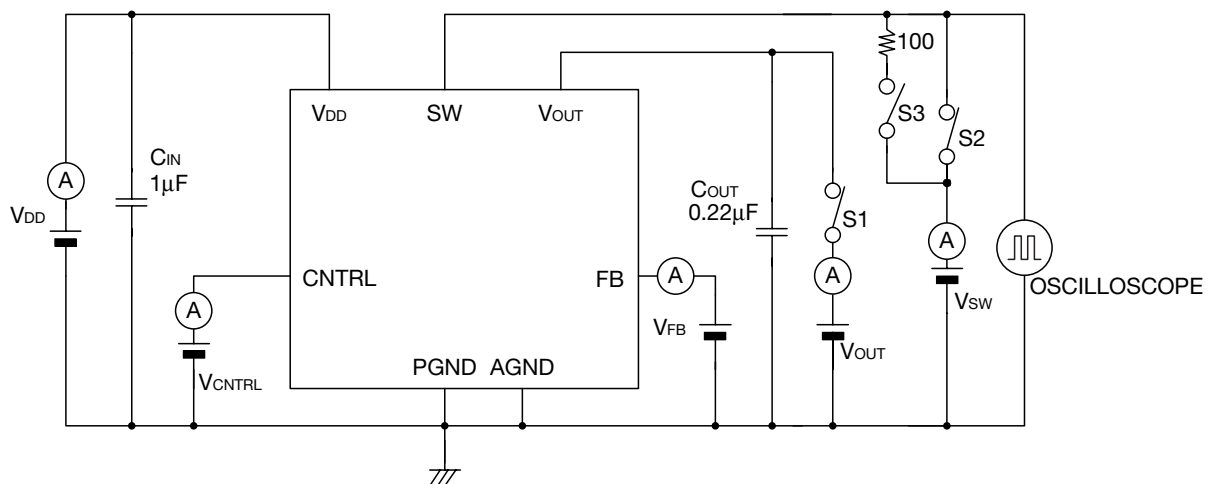

S (n) conditions

	S1	S2	S3
2-A	off	off	off
2-B	off	off	on
2-C	on	on	off

Measuring Circuit 3

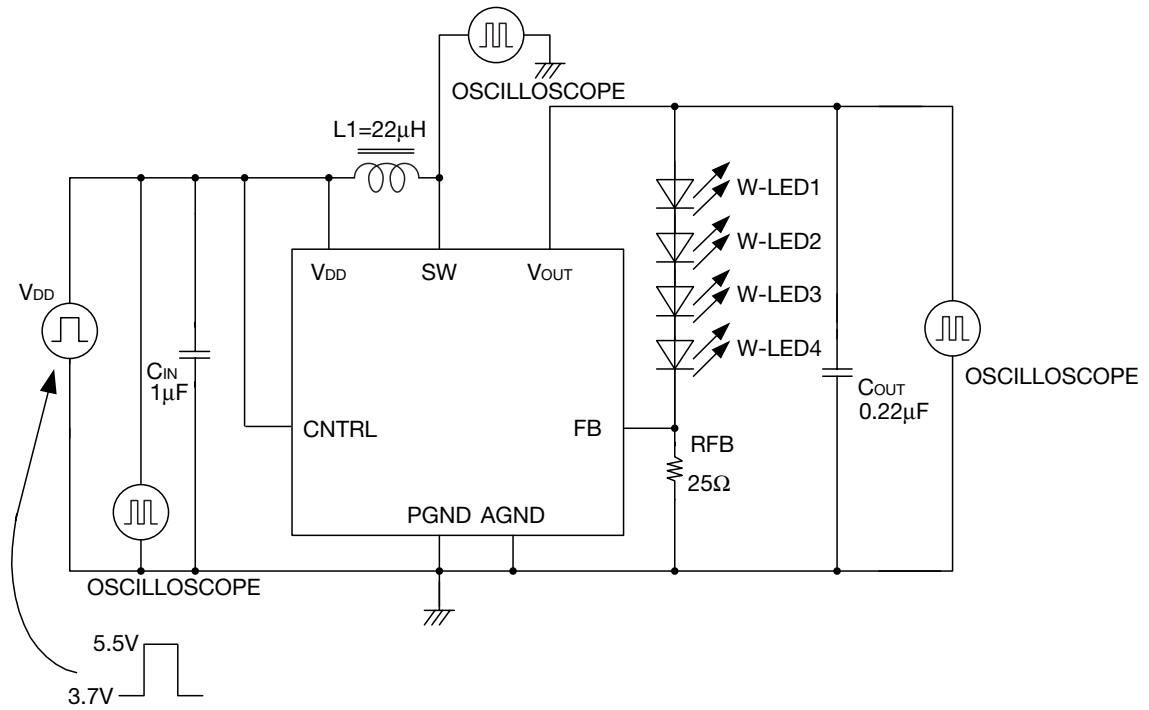

Measuring Circuit 4

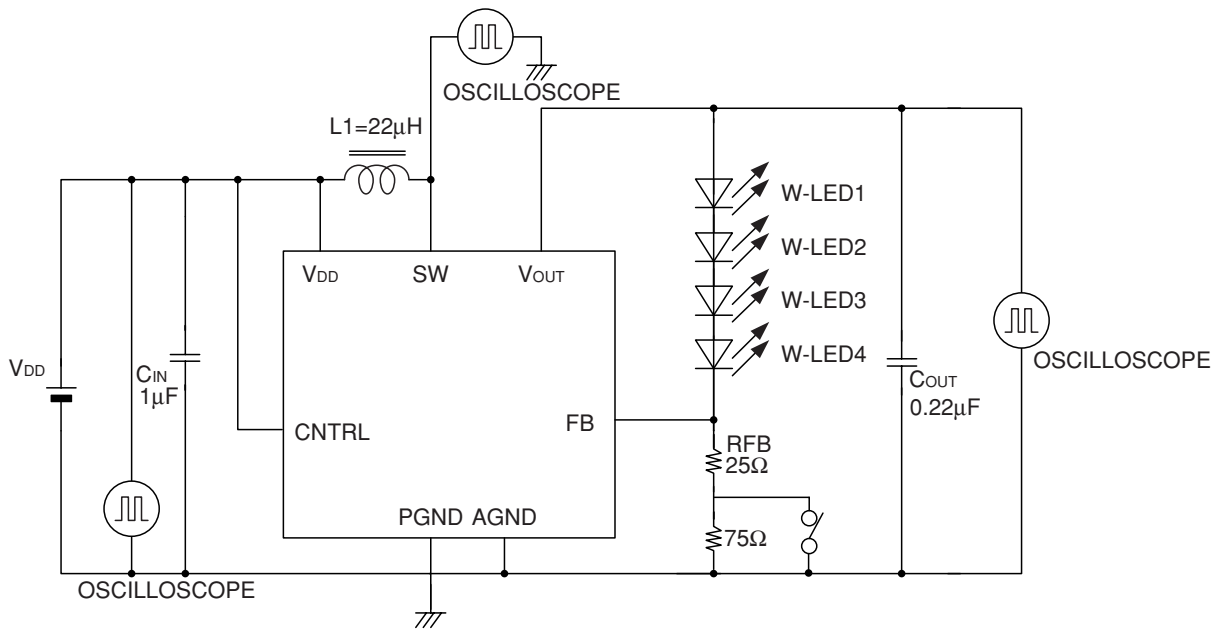

• Any products mentioned in this catalog are subject to any modification in their appearance and others for improvements without prior notification.
 • The details listed here are not a guarantee of the individual products at the time of ordering. When using the products, you will be asked to check their specifications.

Application Circuit

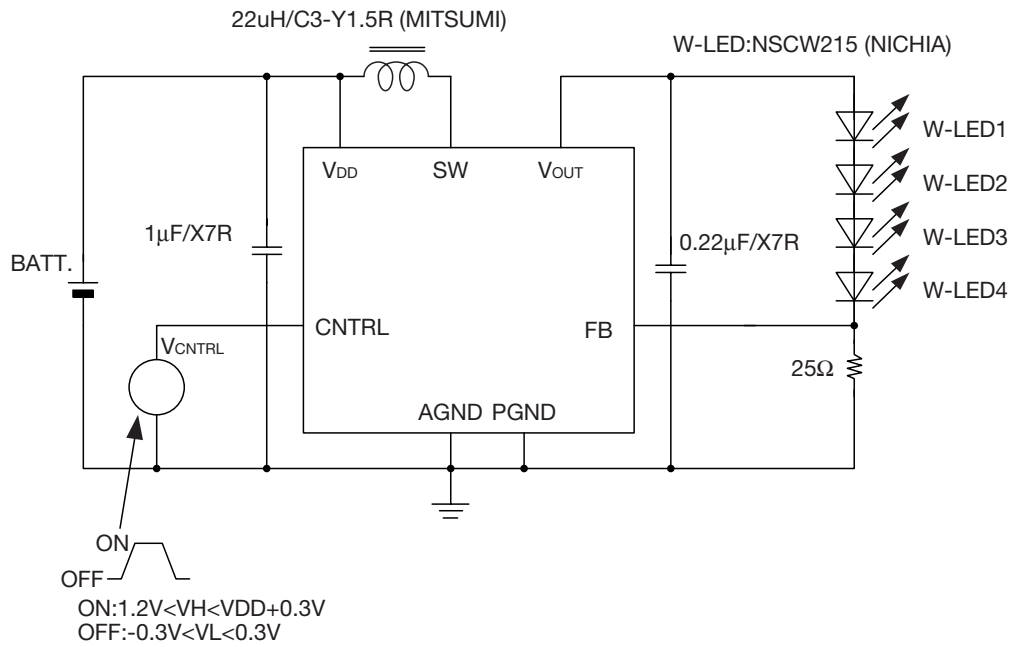

•White LED current in shutdown mode

P-MOSFET is connected in series on the cathode side of the rectifier diode in this IC. This is to prevent a current from going through the white LEDs in shutdown mode. The battery side of the inductor should be connected to the wire common to the VDD pin of the IC in layout to activate this function normally.

See examples below.

Good Example:

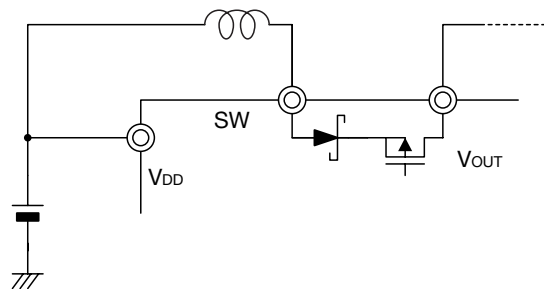

Bad Example:

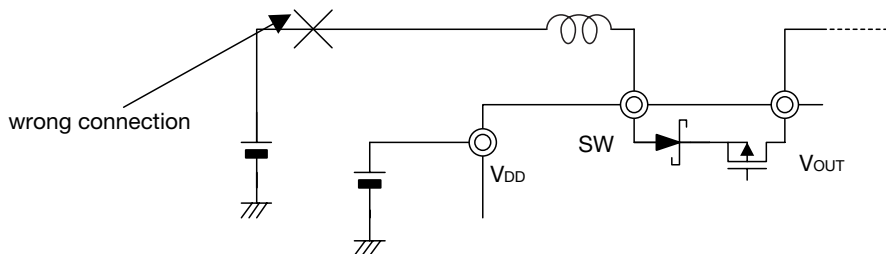

• Any products mentioned in this catalog are subject to any modification in their appearance and others for improvements without prior notification.
 • The details listed here are not a guarantee of the individual products at the time of ordering. When using the products, you will be asked to check their specifications.

Characteristics

Supply current - input voltage (CNTRL="high")

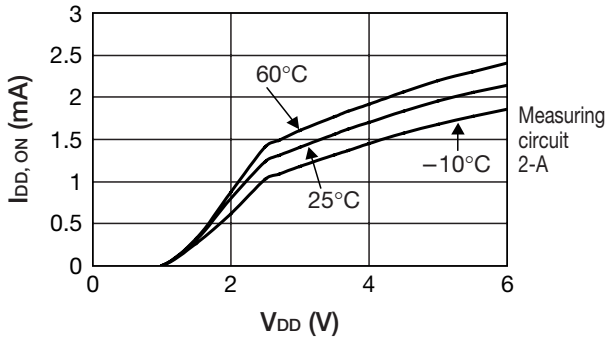

Supply current - input voltage (CNTRL=0V)

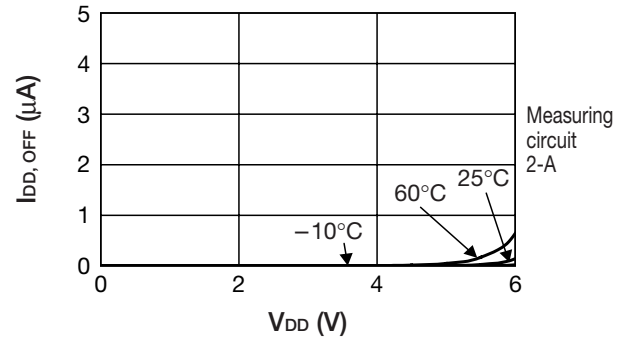

Efficiency - LED current

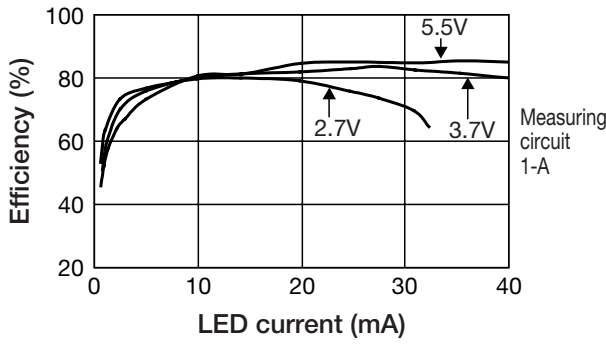

CNTRL bias current - CNTRL voltage

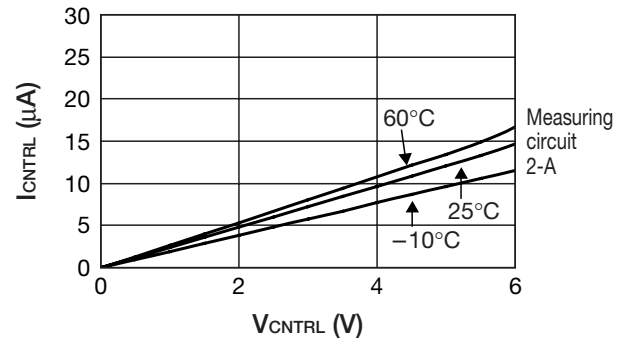

Quiescent LED current - input voltage

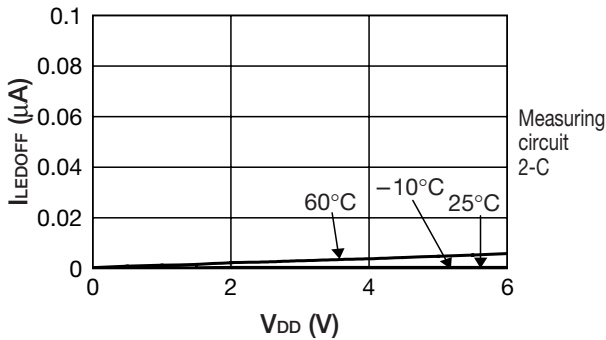

CNTRL threshold voltage - input voltage

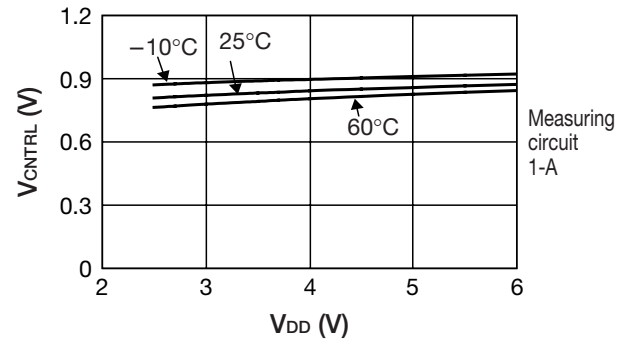

FB bias current - FB voltage

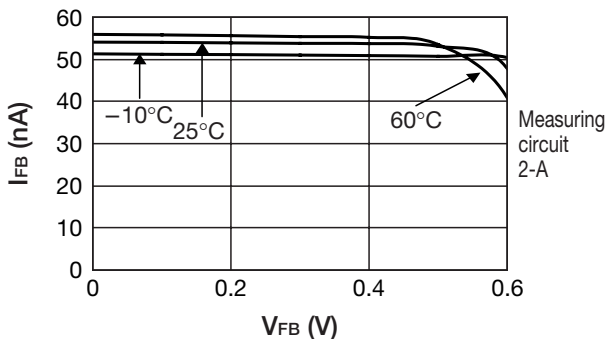

Switching frequency - temperature

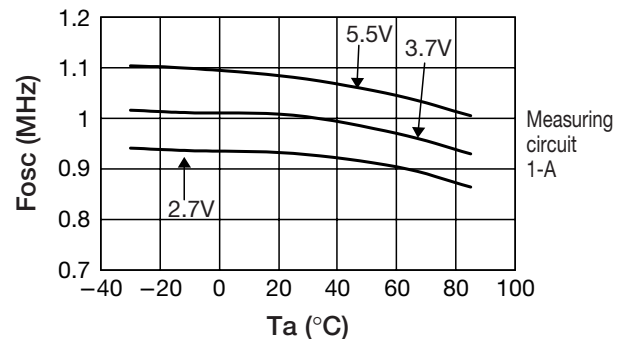

• Any products mentioned in this catalog are subject to any modification in their appearance and others for improvements without prior notification.
 • The details listed here are not a guarantee of the individual products at the time of ordering. When using the products, you will be asked to check their specifications.

■ Efficiency - temperature

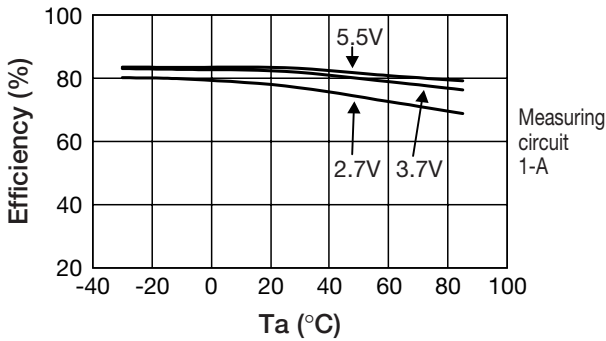

■ Maximum duty cycle - temperature

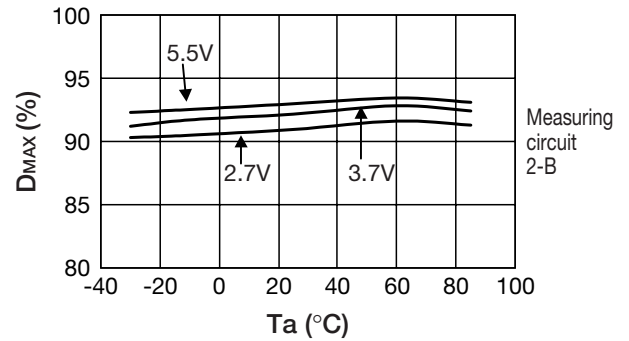

■ Switch Tr leakage current - temperature

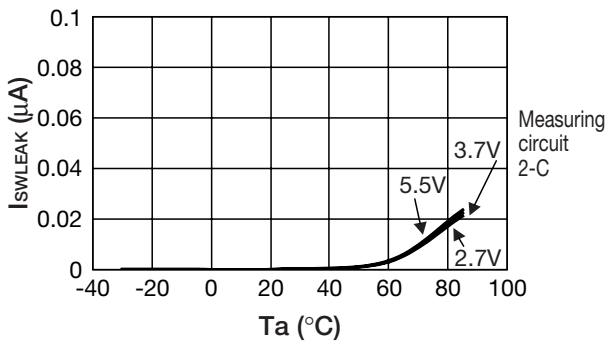

■ Dimming control

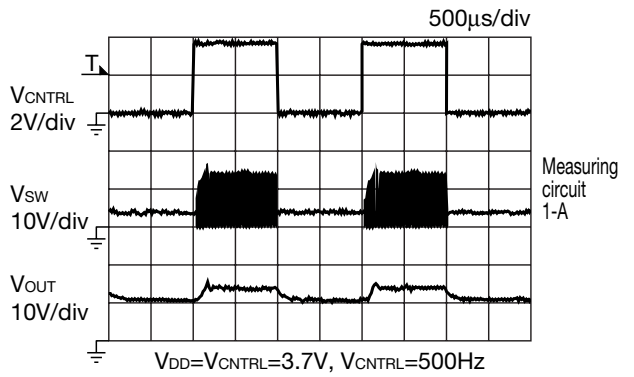

■ Startup waveform with soft-start

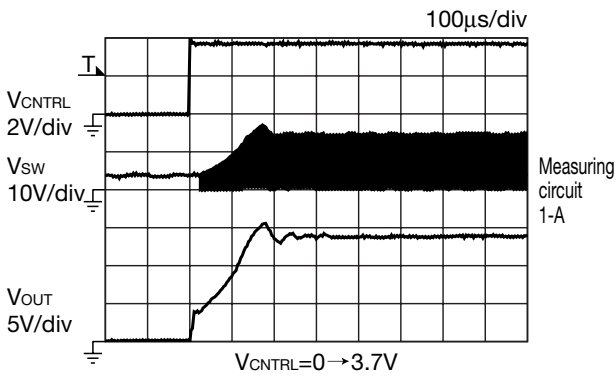

■ Transient response

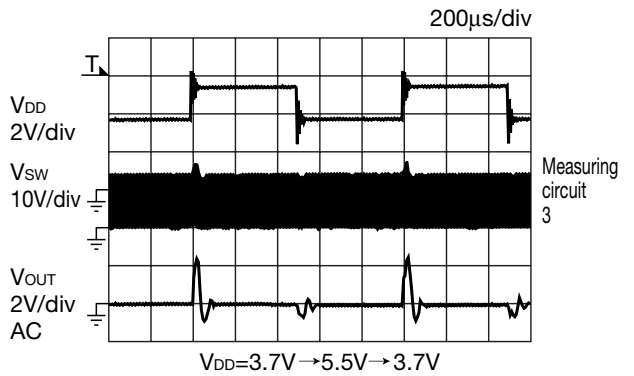

■ Load transient response

