

White LED Driver ICs

Monolithic IC MM3097

Outline

This IC is a white LED driver IC. It is a step-up DC-DC converter IC designed to drive up to 7 LEDs and suitable for backlight drivers. Feedback voltage is as low as 95mV, which can reduce power consumption in a current set resistor. A small 0.22μF capacitor can be used, so that not only space but costs can be reduced.

Features

1. Enables to drive up to 7 white LEDs in a series connection
2. Input voltage range 2.5 to 6V
3. Shutdown current 0.1μA typ.
4. High efficiency 85% typ.
5. Luminance control PWM system
6. Feedback voltage 95mV

Package

SOT-25A

Applications

1. Cell phones
2. Digital video cameras
3. Digital still cameras
4. Portable game devices
5. PDA

Block Diagram

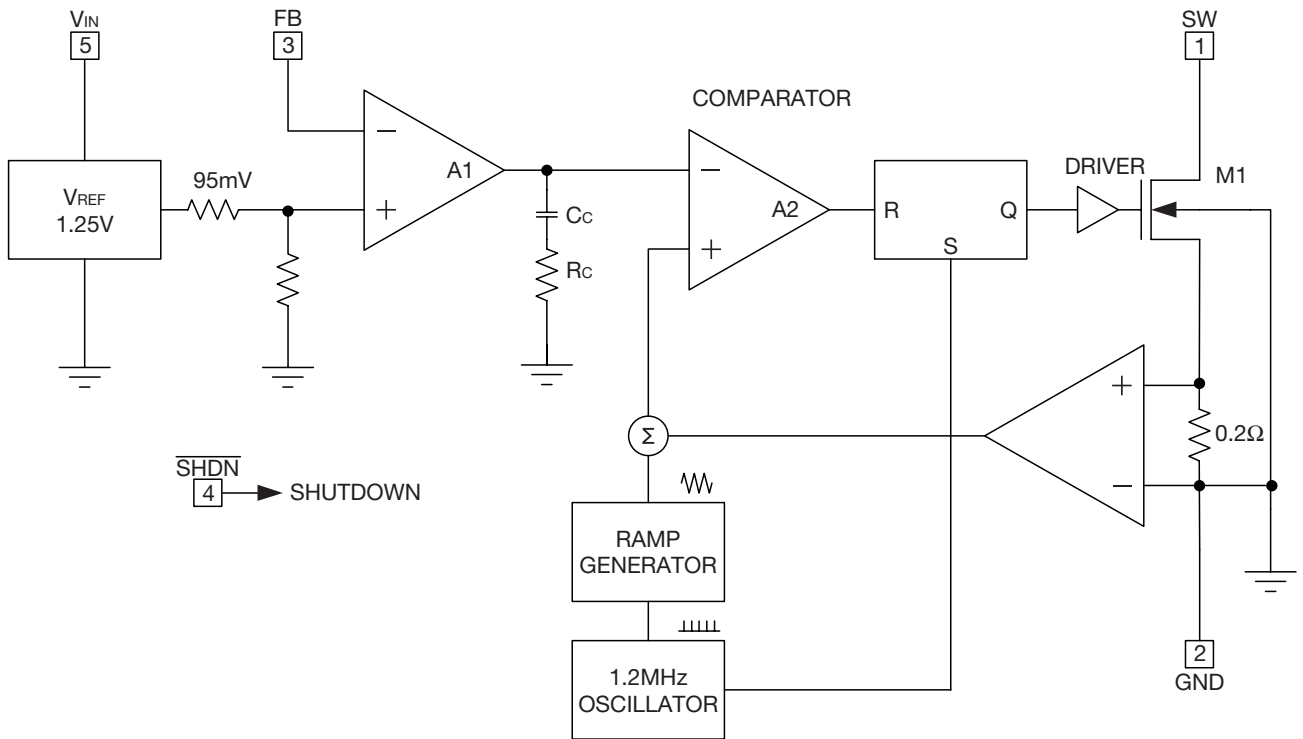

Pin Assignment

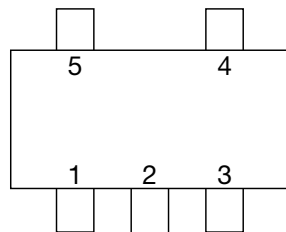

SOT-25A
(TOP VIEW)

1	SW
2	GND
3	FB
4	SHND
5	V _{IN}

Pin Description

Pin No.	Pin name	Functions
1	SW	Switch pin. Connect inductor/diode here. Minimize trace area at this pin to reduce EMI.
2	GND	GND pin.
3	FB	Feedback pin. Reference voltage is 95mV. Connect cathode of lowest LED and resistor.
4	SHDN	Shutdown pin. Tie to 1.5V or higher to enable device; 0.4V or less to disable device.
5	V _{IN}	Input supply pin. Must be locally bypassed.

Absolute Maximum Ratings (Ta=25°C)

Item	Symbol	Ratings	Units
Storage temperature	T _{STG}	-65~+150	°C
Operating temperature	T _{OPR}	-40~+85	°C
Input voltage	V _{INMAX}	8	V
SW voltage	V _{SWMAX}	36	V
FB voltage	V _{FBMAX}	8	V
SHDN voltage	V _{SHDNMAX}	8	V
Allowable loss	P _D	150	mW

Note: Absolute Maximum Ratings are those values beyond which the life of the device may be impaired.

Recommended Operating Conditions

Item	Symbol	Ratings	Units
Operating voltage	V _{OP}	2.5~6	V

Electrical Characteristics 1 (Except where noted otherwise Ta=+25°C, VIN=3V, VSHDN=3V)

Item	Symbol	Measurement conditions	Min.	Typ.	Max.	Units
Feedback voltage	V _{FB}	3LEDs, ILED=15mA	86	95	104	mV
FB pin bias current	I _{FB}		10	45	100	nA
Supply current	I _{SS}			1.0	2.0	mA
		SHDN=0V		0.1	1.0	μA
Switching frequency	f _{sw}		0.8	1.2	1.6	MHz
Maximum duty cycle	MaxDuty		85	90		%
Switch current limit	I _{SWLMT}			320		mA
Switch V _{CESAT}	V _{CESAT}	I _{sw} =250mA		350		mV
Switch leakage current	I _{SWLEAK}	V _{sw} =5V		0.01	5	μA
SHDN voltage high	V _{SHDNH}		1.5			V
SHDN voltage low	V _{SHDNL}				0.4	V
SHDN pin bias current	I _{SHDN}			6		μA

Note: The MM3097 is guaranteed to meet specifications from 0°C to 70°C.

Specifications over the -40°C to 85°C operating temperature range are assured by design, characterization and correlation with statistical process controls.

Electrical Characteristics 2 (Except where noted otherwise Ta=+25°C, VIN=3V, VSHDN=3V)

Item	Symbol	Measurement conditions	Min.	Typ.	Max.	Units
Feedback voltage	V _{FB}	3LEDs, feedback resistor=6.3Ω	86	95	104	mV
FB pin bias current	I _{FB}		10	45	100	nA
Supply current	I _{SS}			1.0	2.0	mA
		SHDN=0V		0.1	1.0	μA
Switching frequency	f _{sw}		0.8	1.2	1.6	MHz
Maximum duty cycle	MaxDuty		85	90		%
Switch current limit	I _{SWLMT}			320		mA
Switch V _{CESAT}	V _{CESAT}	I _{sw} =250mA		350		mV
Switch leakage current	I _{SWLEAK}	V _{sw} =5V		0.01	5	μA
SHDN voltage high	V _{SHDNH}		1.5			V
SHDN voltage low	V _{SHDNL}				0.4	V
SHDN pin bias current	I _{SHDN}			6		μA

Note: The MM3097 is guaranteed to meet specifications from 0°C to 70°C.

Specifications over the -40°C to 85°C operating temperature range are assured by design, characterization and correlation with statistical process controls.

Measuring Circuit

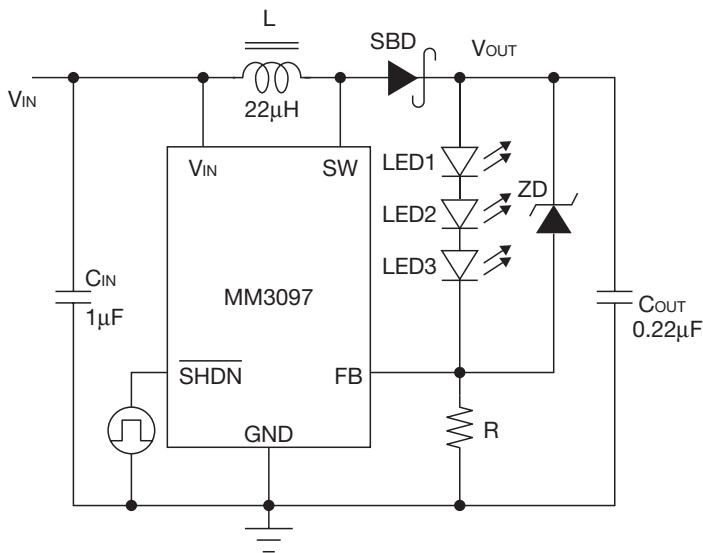

The following is recommended application for MM3097.

Recommend application

L: MITSUMI ELECTRIC C3-Y1.5R (22µH)

SBD: PHILIPS PMEG4005AEA

ZD: ROHM UDZS□B (zener voltage > V_{OUT})

LED: NICHIA NSCW215

Application Circuit

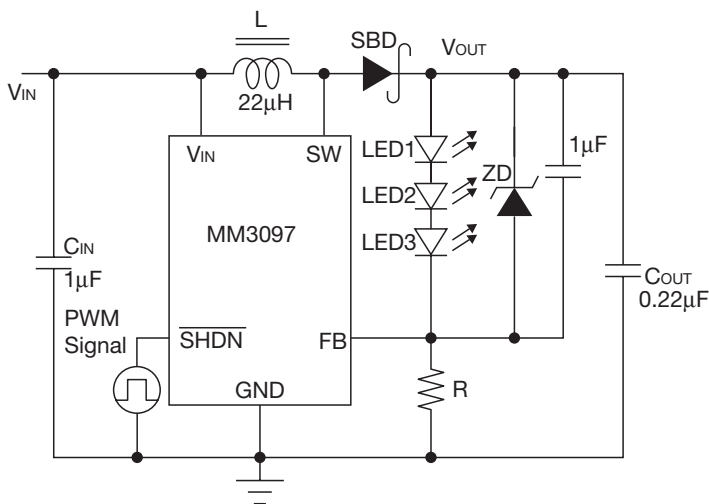

No internal soft-start circuit is included in MM3097.

The capacitor in left figure is recommended for MM3097 if necessary. Dimming control is possible with the PWM signal applied to the SHDN pin.

The magnitude of the PWM signal should be higher than the SHDN voltage high.

Characteristics

■ Quiescent current

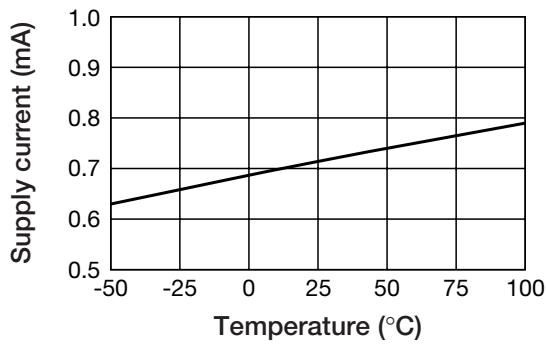

■ Quiescent current

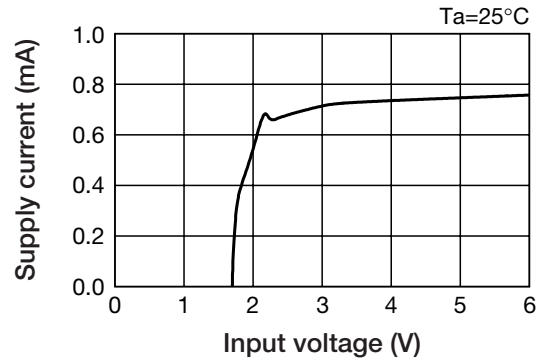

■ Switching frequency

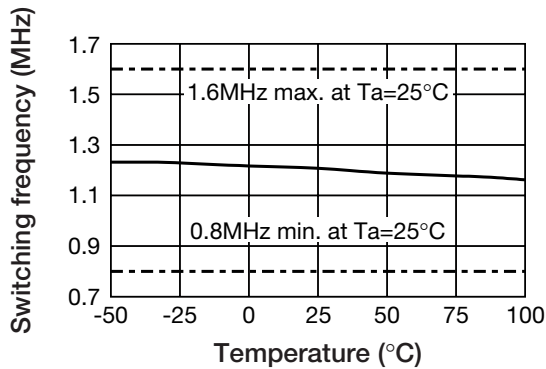

■ Switching frequency

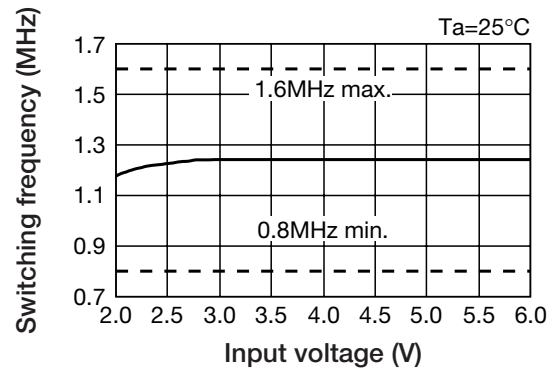

■ Feedback bias current

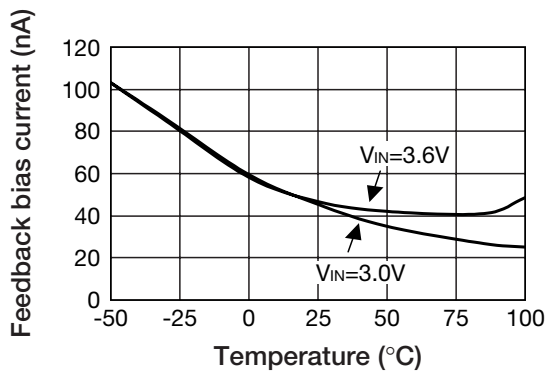

■ FB voltage

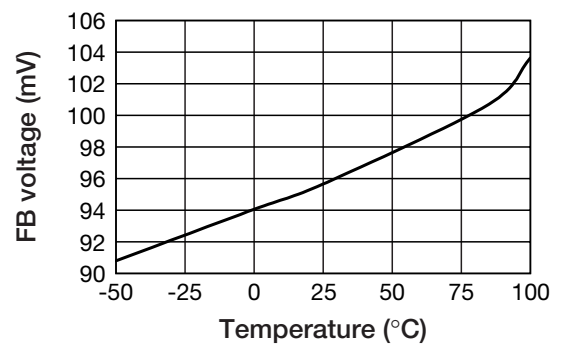

■ SHDN voltage

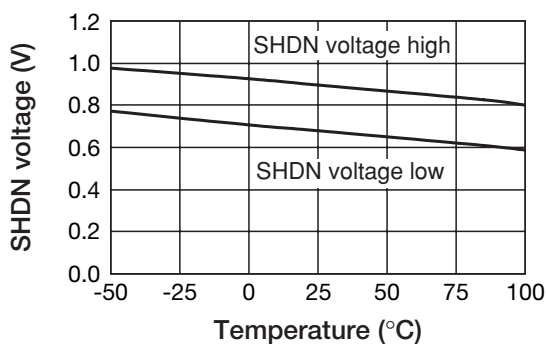

■ SHDN hysteresis voltage

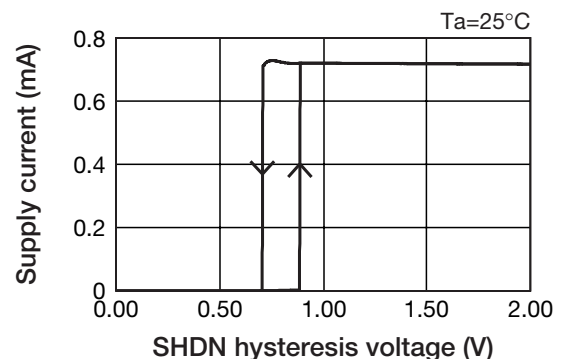

SHDN pin bias current

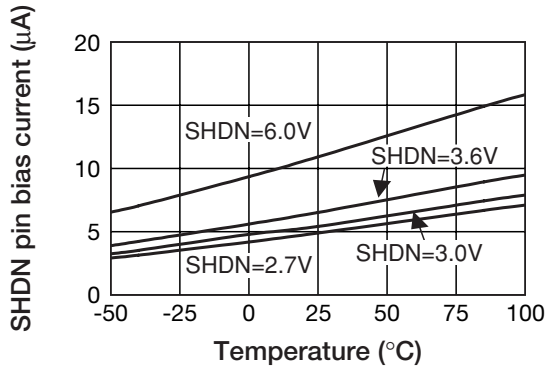

Switching waveform

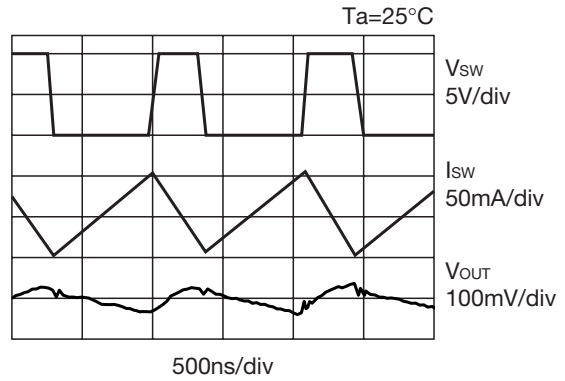

Efficiency (3LEDs)

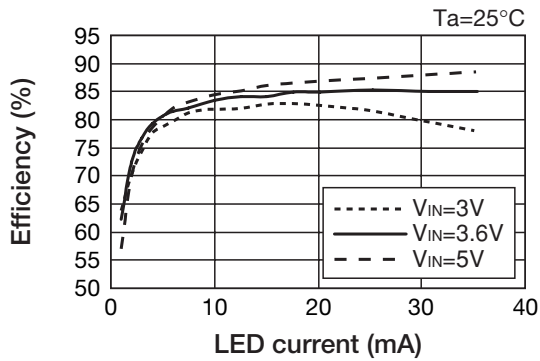

Efficiency (4LEDs)

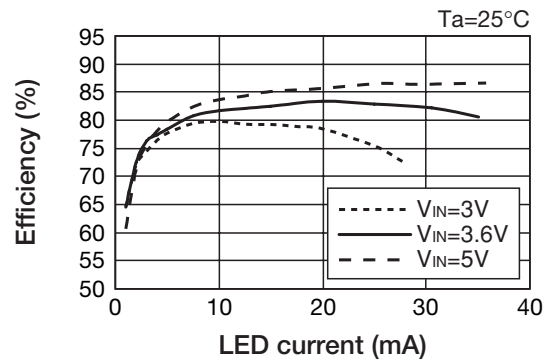

Efficiency (7LEDs)

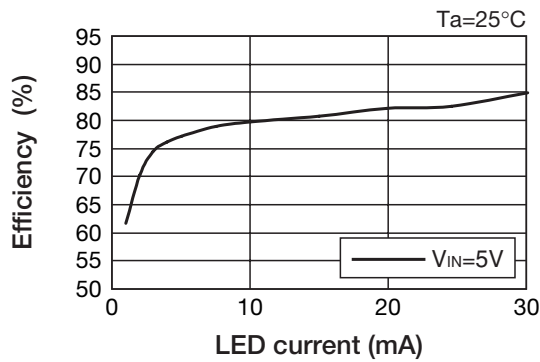

Efficiency

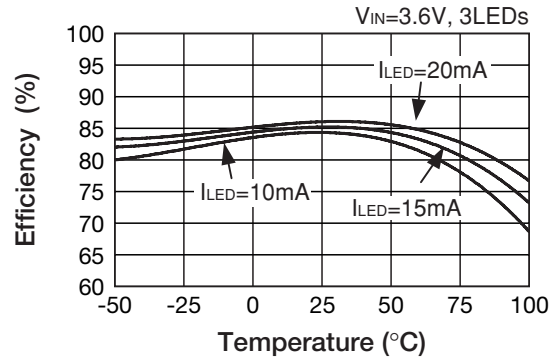

• Any products mentioned in this catalog are subject to any modification in their appearance and others for improvements without prior notification.
 • The details listed here are not a guarantee of the individual products at the time of ordering. When using the products, you will be asked to check their specifications.

LED Current Control

The LED current is controlled by the feedback resistor (R in Measuring Circuit).
 The feedback reference is 95mV, so the LED current is 95mV/R.

$$I_{LED} = 95mV/R$$

The relation between LED current and resistance R is shown in Table.1.

Table.1 Selection of Resistance R

I _{LED} (mA)	R (Ω)
5	19
10	9.5
12	8.0
15	6.3
20	4.5

Applications Information

Inductor Selection

A 22μH inductor is recommended for MM3097 applications.

Small size and high efficiency are the major concerns for most applications.

Inductors with low core losses and small DCR (copper wire resistance) at 1.2MHz are good choices for applications.

Some inductors in this category with small size are listed in Table.2.

The efficiency comparison of different inductors is shown in Figure.1.

Table.2 Recommend Inductors

Part number	DCR (mΩ)	Current rating (mA)	Manufacturer
C3-Y1.5R 22μH	660	550	Kyushu Mitsumi
C3-Y1.5R 10μH	275	900	
C3-Y1.5R 33μH	995	500	
C3-Y1.5R 47μH	1220	430	

Figure.1 Efficiency comparison of different inductors

