

Multifunction PMIC

Monolithic IC MM3264XV

March, 2008

Outline

This IC is a multiple output power supply IC incorporating a 2-channel synchronous step-down DC-DC converter, LED driver circuit.

Both converters in this IC are synchronized to a single oscillator and run with opposite phase, reducing input ripple current, which realizes lower noise.

The MM3264 provides easy solutions as it is optimized for storage devices.

Features

- | | |
|---|-------------------------------------|
| 1. Input Voltage Range | 4.5V~5.5V |
| 2. Output Voltage | $V_{OUT1}=1.2V/1.5V, V_{OUT2}=3.3V$ |
| 3. Output Voltage accuracy | $V_{OUT}\pm 2\%$ |
| 4. Maximum Output Current | 800mA |
| 5. Efficiency | 92% and up |
| 6. Oscillation Frequency | 1MHz (typ.) |
| 7. Soft Start Function | |
| 8. V_{OUT1} Output Voltage Control Function | |
| 9. Built-in Reset Circuit | |
| 10. Reset Detection Voltage V_{IN}/V_{OUT2} | |
| 11. Built-in LED Driver Circuit | |
| 12. Pch Current Switch Circuit | |
| 13. Input Over Voltage Detection | |
| 14. Over Current Detection | |
| 15. UVLO Detection | |
| 16. Thermal Protect Function | |

Package

TSOP-20C

Applications

1. Storage Devices
2. etc.

Block Diagram

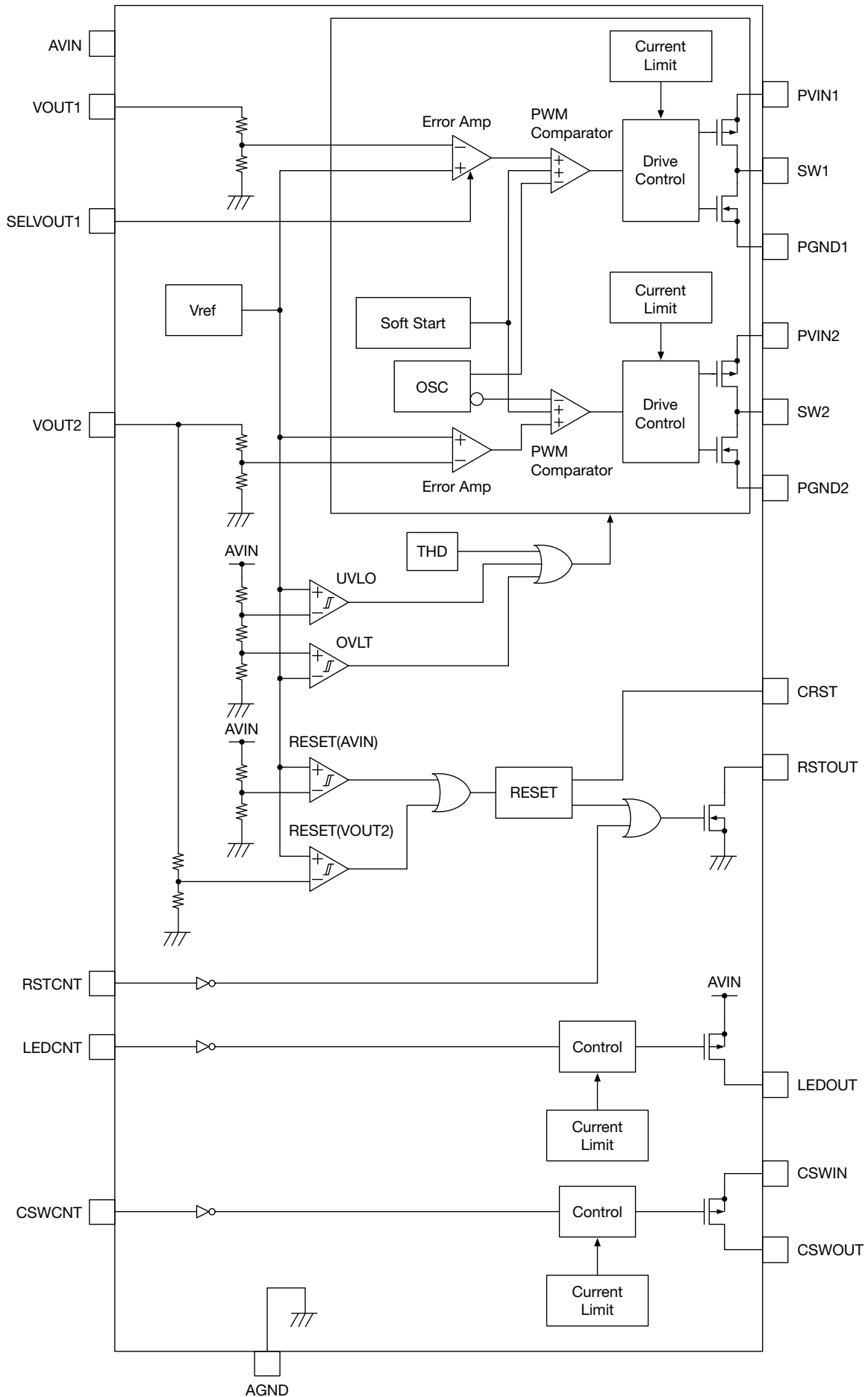

• Any products mentioned in this catalog are subject to any modification in their appearance and others for improvements without prior notification.
 • The details listed here are not a guarantee of the individual products at the time of ordering. When using the products, you will be asked to check their specifications.

Pin Assignment

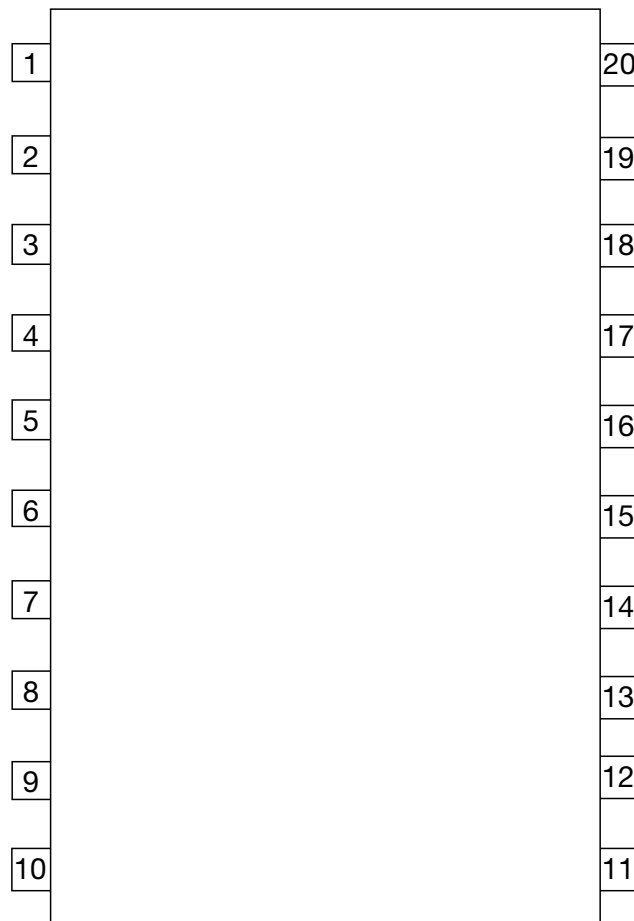

TSOP-20C
(TOP VIEW)

1	SW1	11	RSTOUT
2	CSWCNT	12	VOUT2
3	PVIN1	13	CRST
4	LEDCNT	14	AGND
5	PGND1	15	RSTCNT
6	PGND2	16	VOUT1
7	SELVOUT1	17	LEDOUT
8	PVIN2	18	AVIN
9	NC	19	CSWIN
10	SW2	20	CSWOUT

Pin Description

Pin No.	Pin name	I/O	Pin description	Internal equivalent circuit diagram
1,10	SW1 SW2	Output	Power switched pin	
2,4,7,15	CSWCNT LEDCNT SELVOUT1 RSTCNT	Input	Control signal input pin	
3,8,18,19	PVIN1 PVIN2 AVIN CSWIN	Input	Power voltage supply input pin	
5,6,14	PGND1 PGND2 AGND		Ground pin	
11	RSTOUT	Output	Reset output pin	
12	VOUT2	Input	Output voltage feedback pin for 3.3V output	

• Any products mentioned in this catalog are subject to any modification in their appearance and others for improvements without prior notification.
 • The details listed here are not a guarantee of the individual products at the time of ordering. When using the products, you will be asked to check their specifications.

Pin No.	Pin name	I/O	Pin description	Internal equivalent circuit diagram
13	CRST	Input	Capacitor connect pin with delay	
16	VOUT1	Input	Output voltage feedback pin for 1.2V/1.5V output	
17	LEDOUT	Output	LED driver output pin	
19	CSWIN	Output	Current Switch input pin	
20	CSWOUT	Output	Current Switch output pin	

• Any products mentioned in this catalog are subject to any modification in their appearance and others for improvements without prior notification.
 • The details listed here are not a guarantee of the individual products at the time of ordering. When using the products, you will be asked to check their specifications.

Absolute Maximum Ratings (Except where noted otherwise Ta=25°C)

Item	Symbol	Ratings	Units
Storage Temperature	T _{STG}	-55~+150	°C
Operating Temperature	T _{OPR}	-30~+70	°C
PVIN1 Voltage	VPVIN1	-0.3~7	V
PVIN2 Voltage	VPVIN2	-0.3~7	V
AVIN Voltage	VAVIN	-0.3~7	V
SW1 Voltage	V _{SW1}	-0.3~VAVIN+0.3	V
SW2 Voltage	V _{SW2}	-0.3~VAVIN+0.3	V
VOUT1 Voltage	V _{OUT1}	-0.3~VAVIN+0.3	V
VOUT2 Voltage	V _{OUT2}	-0.3~VAVIN+0.3	V
LEDCNT Voltage	V _{LEDCNT}	-0.3~VAVIN+0.3	V
SELVOUT1 Voltage	V _{SELVOUT1}	-0.3~VAVIN+0.3	V
RSTOUT Voltage	V _{RSTOUT}	-0.3~VAVIN+0.3	V
CRST Voltage	V _{CRST}	-0.3~VAVIN+0.3	V
RSTCNT Voltage	V _{RSTCNT}	-0.3~VAVIN+0.3	V
LEDOUT Voltage	V _{LEDOUT}	-0.3~VAVIN+0.3	V
CSWCNT Voltage	V _{CSWCNT}	-0.3~VAVIN+0.3	V
CSWIN Voltage	V _{CSWIN}	-0.3~VAVIN+0.3	V
CSWOUT Voltage	V _{CSWOUT}	-0.3~VAVIN+0.3	V
SW1 Maximum Current	I _{SW1}	1.0	A
SW2 Maximum Current	I _{SW2}	1.0	A
LEDOUT Maximum Current	I _{LEDOUT}	0.1	A
CSWOUT Maximum Current	I _{CSWOUT}	0.2	A
RSTOUT Maximum Current	I _{RSTOUT}	2.0	mA
Power dissipation	P _d	400 (Alone) (Note1)	mW

Note1 : The values indicate reference values.

Recommended Operating Conditions (Except where noted otherwise Ta=25°C)

Item	Symbol	Ratings	Units
Operating Supply Voltage	V _{OP}	4.5~5.5	V
Operating Temperature	T _{OP}	-30~+70	°C

Electrical Characteristics

(Except where noted otherwise VPVIN1=VPVIN2=VPVIN=5.0V, Ta=25°C)

Item	Symbol	Measurement conditions	Min.	Typ.	Max.	Units	Measuring Circuit No.
PVIN1 Input Voltage Range	VPVIN1	VPVIN1=VPVIN2=VAVIN	4.5	5.0	5.5	V	
PVIN2 Input Voltage Range	VPVIN2	VPVIN1=VPVIN2=VAVIN	4.5	5.0	5.5	V	
AVIN Input Voltage Range	VAVIN	VPVIN1=VPVIN2=VAVIN	4.5	5.0	5.5	V	
Supply Current	I _{SS}	VPVIN1=VPVIN2=VAVIN=5.0V V _{OUT1} =V _{OUT2} =5.0V RSTCNT=LEDCNT=5V CSWCNT=SELV _{OUT1} =0V		1.6	2.4	mA	2
Over Voltage Detection Voltage	V _{OVLO}	VAVIN=5.5V→7V		6.6		V	1
UVLO Detection Voltage	V _{UVLO}	VAVIN=5.5V→0V		3.65		V	1
UVLO Hysteresis Voltage	ΔV _{UVLO}			100		mV	1
DC-DC Converter							
V _{OUT1} Output Voltage 1	V _{OUT1A}	SELV _{OUT1} =L	1.47	1.5	1.53	V	1
V _{OUT1} Output Voltage 2	V _{OUT1B}	SELV _{OUT1} =H	1.176	1.2	1.224	V	1
V _{OUT2} Output Voltage	V _{OUT2}		3.234	3.3	3.366	V	1
Oscillator Frequency	f _{OSC}	VPVIN1=VPVIN2=VAVIN=5.0V	0.8	1	1.2	MHz	1
SW Tr Current Limit (Note2)	I _{lim}	V _{OUT} ×0.9		1.2		A	1
SW1 pin "High" ON Resistance	R _{SW1H}	VPVIN1=VPVIN2=VAVIN=5.0V	0.18	0.3	0.5	Ω	2
SW1 pin "Low" ON Resistance	R _{SW1L}	VPVIN1=VPVIN2=VAVIN=5.0V	0.15	0.25	0.45	Ω	2
SW2 pin "High" ON Resistance	R _{SW2H}	VPVIN1=VPVIN2=VAVIN=5.0V	0.18	0.3	0.5	Ω	2
SW2 pin "Low" ON Resistance	R _{SW2L}	VPVIN1=VPVIN2=VAVIN=5.0V	0.15	0.25	0.45	Ω	2
Soft Start Time	t _{SS}	Time till it reaches to V _{OUT} ×0.9 after power supply is input.	0.5	1.5	2.5	ms	1
SELV _{OUT1} pin "High" Input Voltage	V _{SEL1H}		2			V	1
SELV _{OUT1} pin "Low" Input Voltage	V _{SEL1L}				0.8	V	1
SELV _{OUT1} pin Input Current	I _{SEL1}	V _{SEL1} =5.0V	-2.5		2.5	μA	1
Reset							
Reset Detection Voltage	V _{RSTON1}	Monitor AVIN Voltage	3.60	3.70	3.80	V	3
	V _{RSTON2}	Monitor 3.3V Output Voltage	2.59	2.70	2.81	V	3
Reset Hysteresis Voltage	ΔV _{RST1}	Monitor AVIN Voltage	140	200	260	mV	3
	ΔV _{RST2}	Monitor 3.3V Output Voltage	70	100	130	mV	3
Reset Output Sink Current	I _{RSTSINK}		1.0			mA	3
Reset Output Leakage Current	I _{RSTLK}		-3.0		3.0	μA	3
Reset Delay Time	t _{RST}	Connect 0.1μF to CRST pin	30	50	70	ms	3
RSTCNT pin "High" Input Voltage	V _{RSTCNTH}		1.0	1.4	1.8	V	3
RSTCNT pin "Low" Input Voltage	V _{RSTCNTL}		0.8	1.2	1.6	V	3
RSTCNT pin Hysteresis Voltage	ΔV _{RSTCNT}		70	200	330	mV	3
RSTCNT pin Input Current	I _{RSTCNT}		-2.5		2.5	μA	3

• Any products mentioned in this catalog are subject to any modification in their appearance and others for improvements without prior notification.
 • The details listed here are not a guarantee of the individual products at the time of ordering. When using the products, you will be asked to check their specifications.

Item	Symbol	Measurement conditions	Min.	Typ.	Max.	Units	Measuring Circuit No.
LED Driver							
LED Driver On Resistance	RLEDO	LEDCNT=L		5	10	Ω	3
LEDCNT pin "High" Input Voltage	VLEDH		2.0			V	3
LEDCNT pin "Low" Input Voltage	VLEDL				0.8	V	3
LEDCNT pin Input Current	IvLED		-10		10	μA	3
Current Switch							
Current Switch Driver On Resistance	RCSW	CSWCNT=H		0.6	1.0	Ω	3
CSWCNT pin "High" Input Voltage	VCSWH		2.0			V	3
CSWCNT pin "Low" Input Voltage	VCSWL				0.8	V	3
CSWCNT pin Input Current	IvCSW		-10		10	μA	3

Note2 : Design value

Measuring Circuit 1

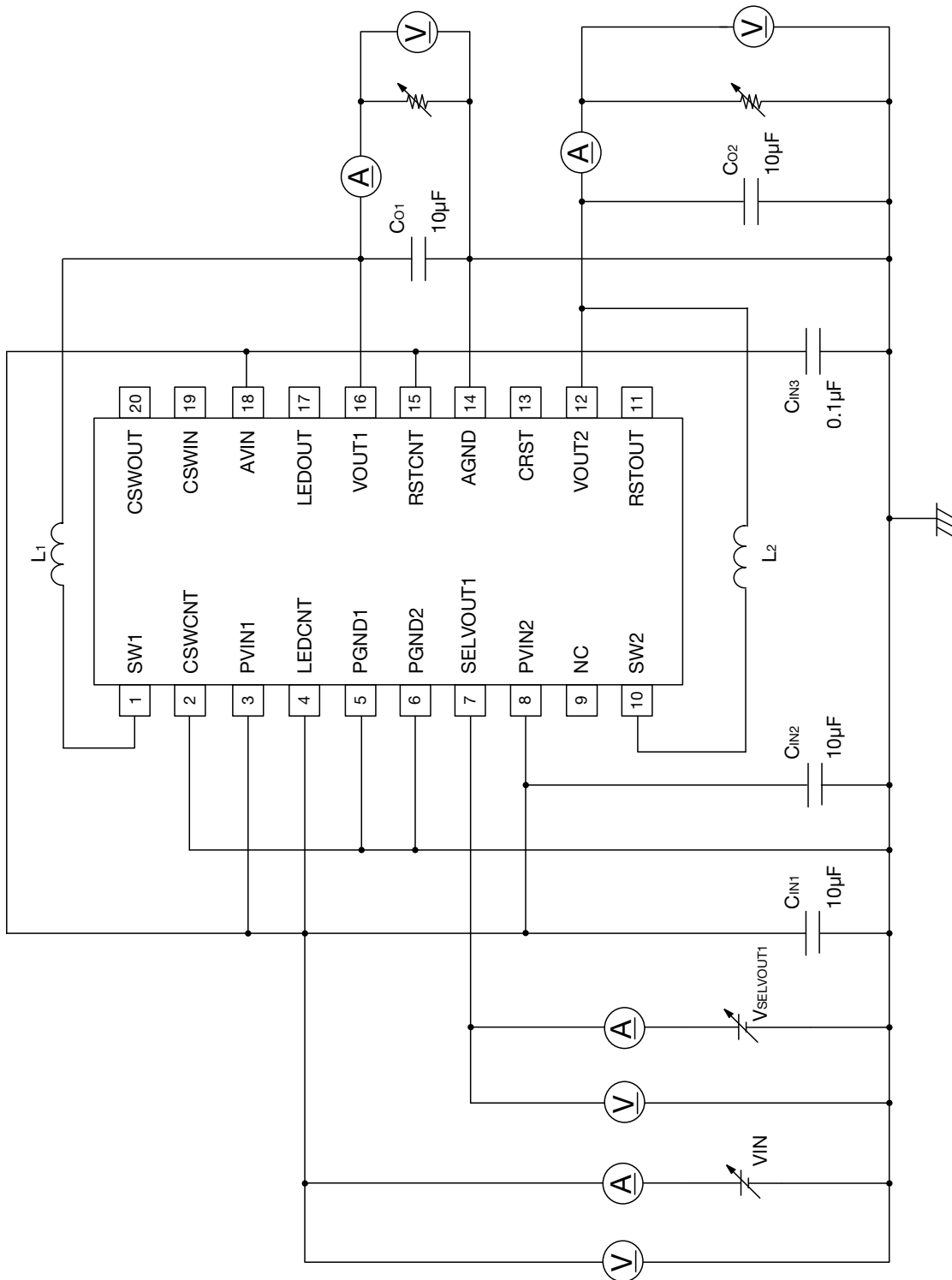

- Any products mentioned in this catalog are subject to any modification in their appearance and others for improvements without prior notification.
- The details listed here are not a guarantee of the individual products at the time of ordering. When using the products, you will be asked to check their specifications.

Measuring Circuit 2

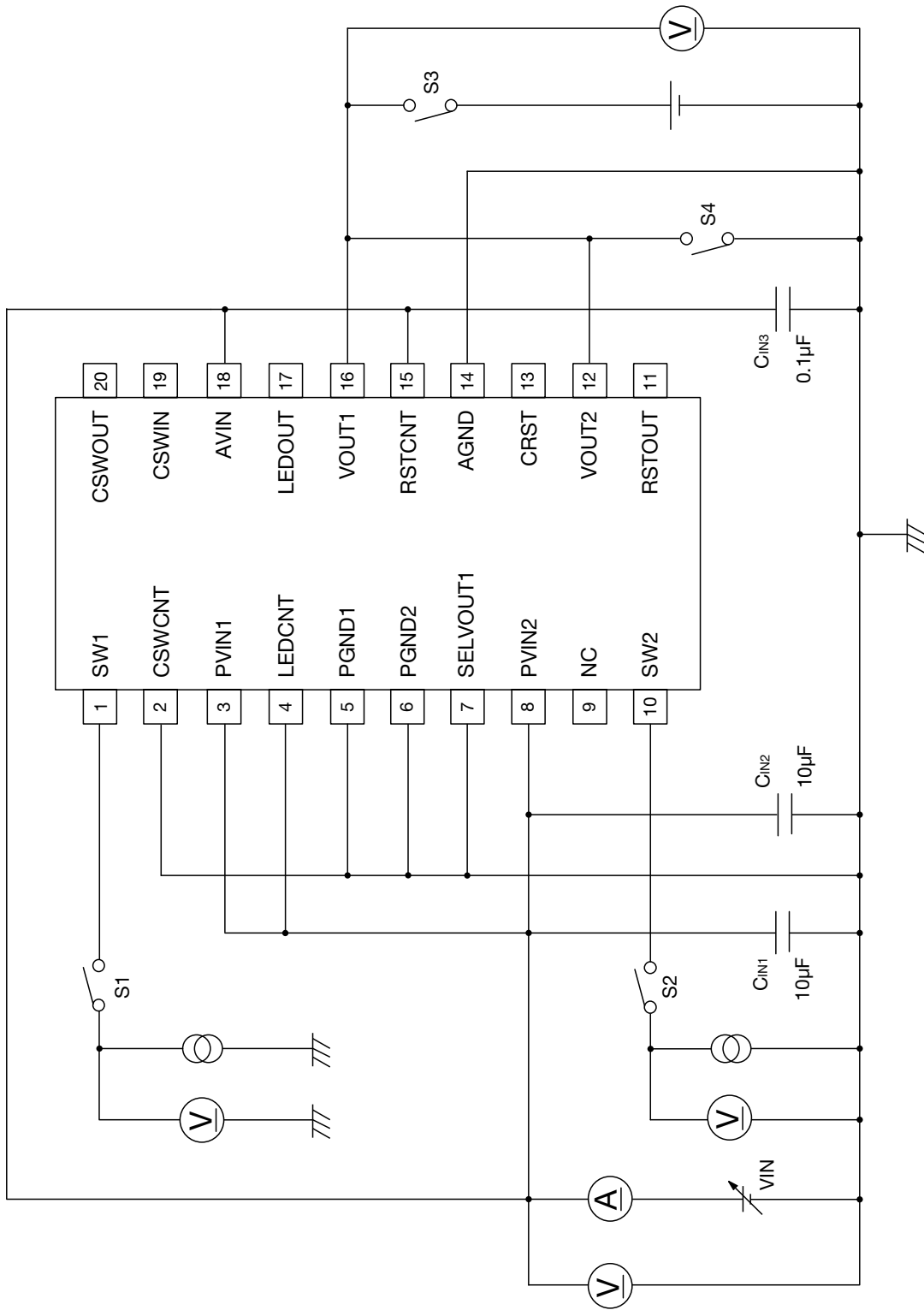

• Any products mentioned in this catalog are subject to any modification in their appearance and others for improvements without prior notification.
 • The details listed here are not a guarantee of the individual products at the time of ordering. When using the products, you will be asked to check their specifications.

Measuring Circuit 3

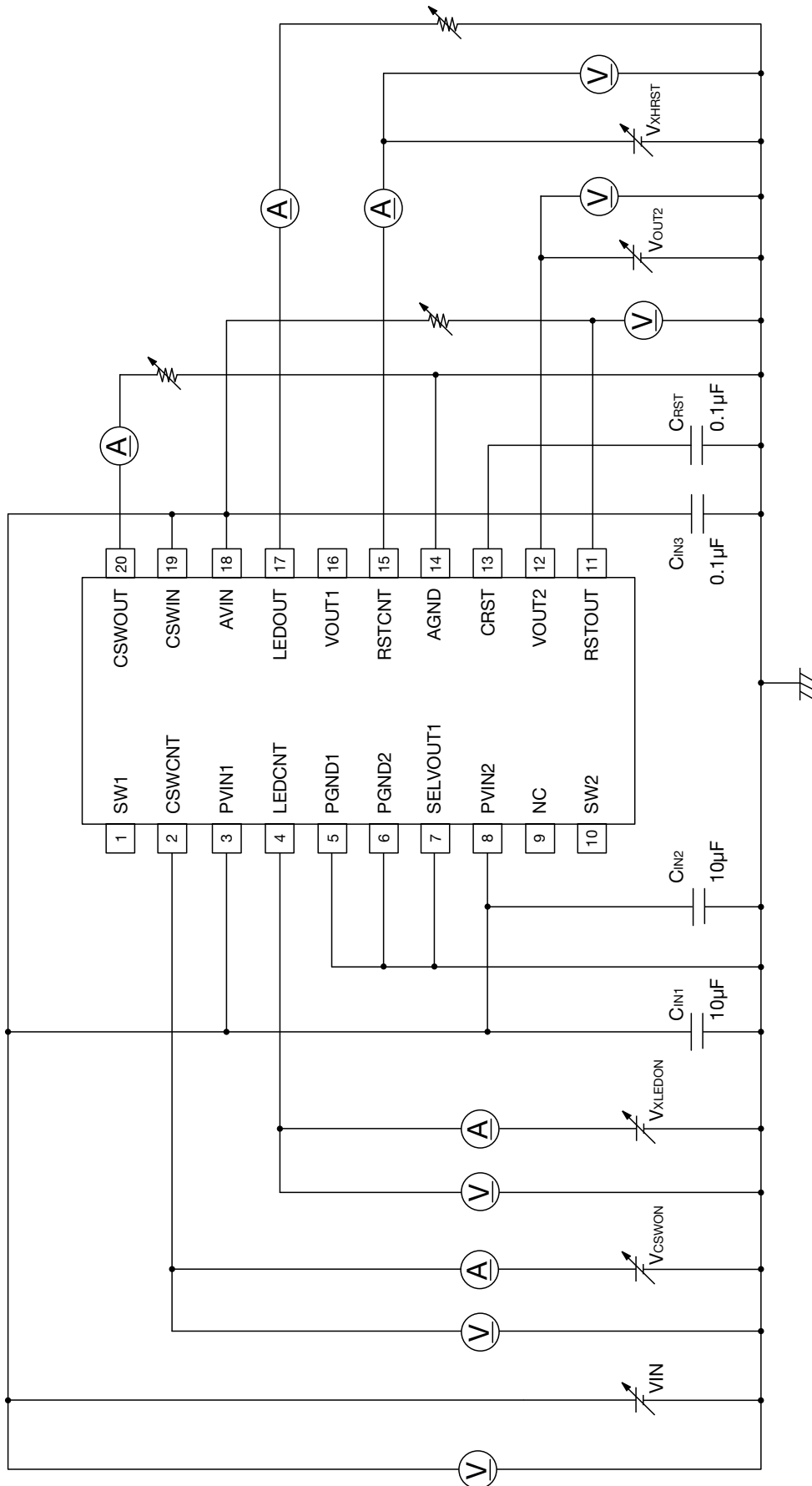

• Any products mentioned in this catalog are subject to any modification in their appearance and others for improvements without prior notification.
 • The details listed here are not a guarantee of the individual products at the time of ordering. When using the products, you will be asked to check their specifications.

Application Circuit

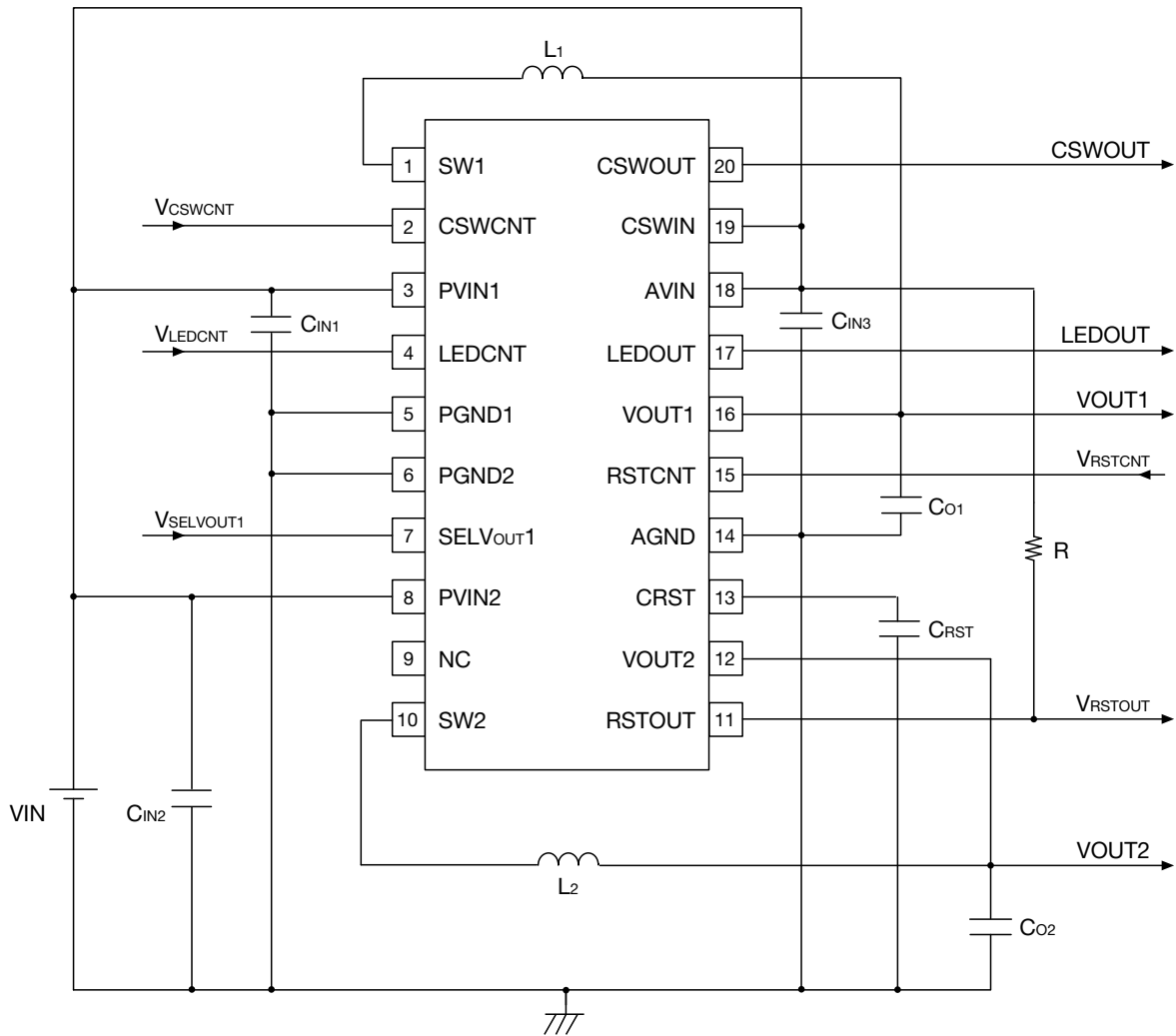

External Part

- Inductor : MITSUMI 10 μ H (C4-K1.8R)
- Output Capacitor : Murata 10 μ F (GRM21B31A106KE18)
- Input Capacitor : Murata 10 μ F (GRM21B31A106KE18)
- CRST Capacitor : Murata 0.1 μ F (GRM188B11C104KA01)

• Any products mentioned in this catalog are subject to any modification in their appearance and others for improvements without prior notification.
 • The details listed here are not a guarantee of the individual products at the time of ordering. When using the products, you will be asked to check their specifications.

Timing Chart

(1) Start Up & Protect operation

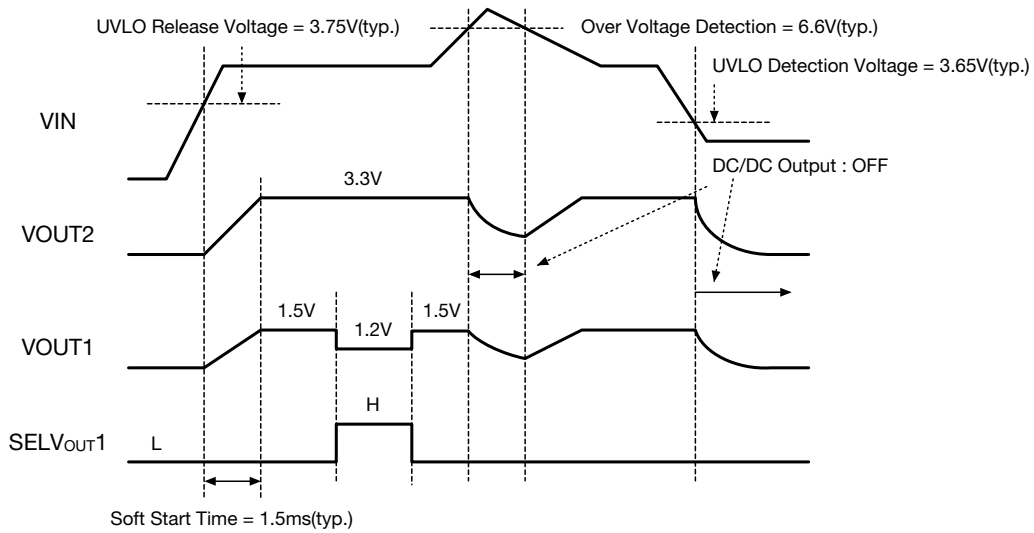

(2) Output Short

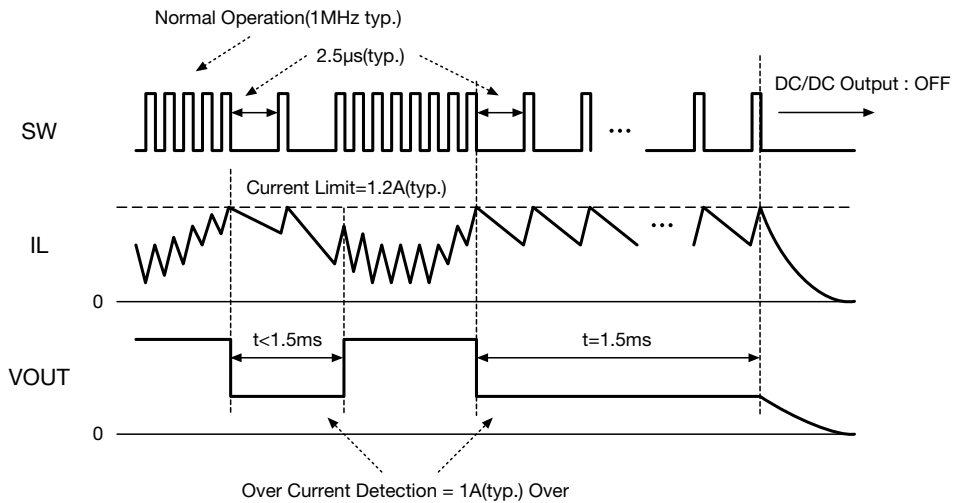

(3) Reset Output

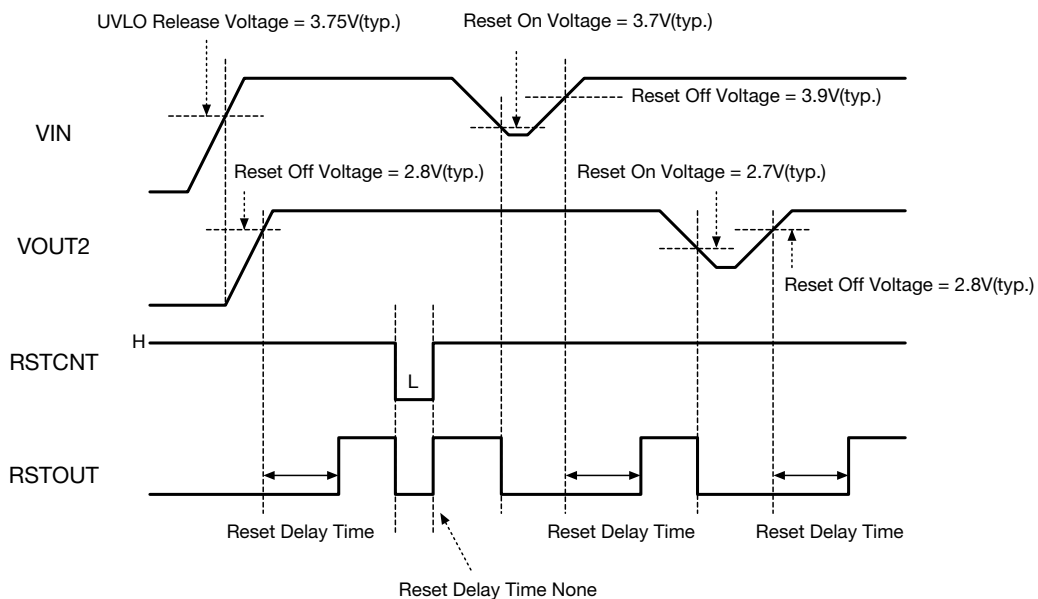

• Any products mentioned in this catalog are subject to any modification in their appearance and others for improvements without prior notification.
 • The details listed here are not a guarantee of the individual products at the time of ordering. When using the products, you will be asked to check their specifications.

Characteristics (Except where noted otherwise $V_{PVIN1}=V_{PVIN2}=V_{PVIN}=5.0V$, $T_a=25^{\circ}C$)

Efficiency - Output current (1)

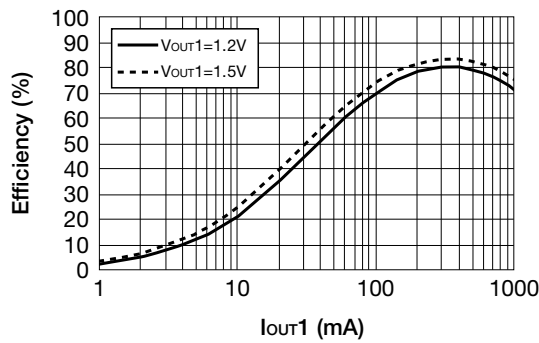

Efficiency - Output current (2)

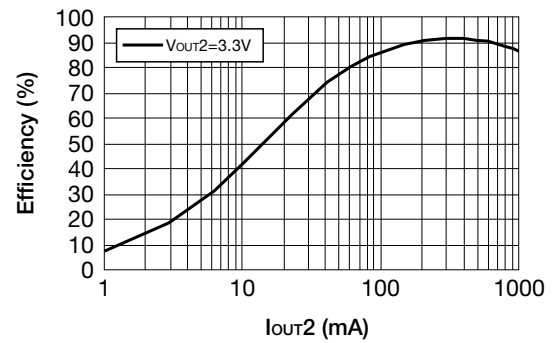

Output voltage - Output current (1)

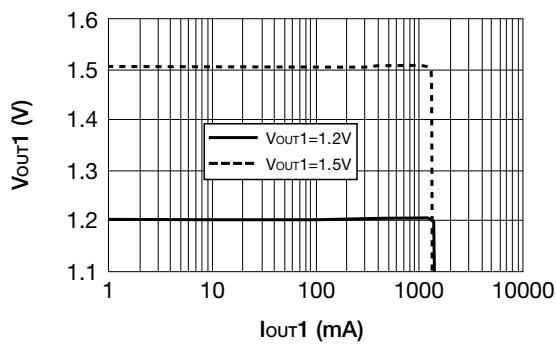

Output voltage - Output current (2)

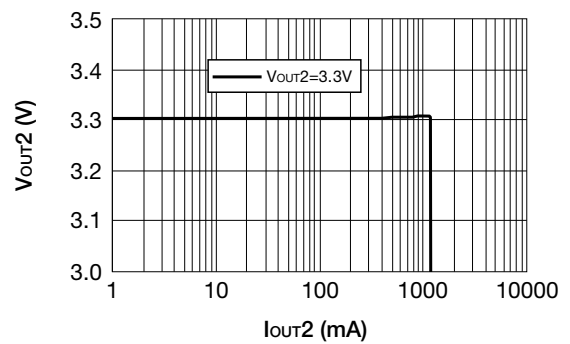

Output voltage - Input voltage (1)

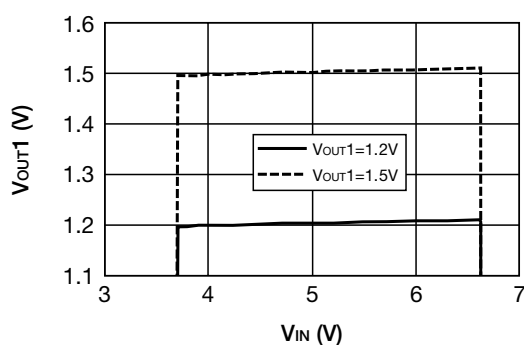

Output voltage - Input voltage (2)

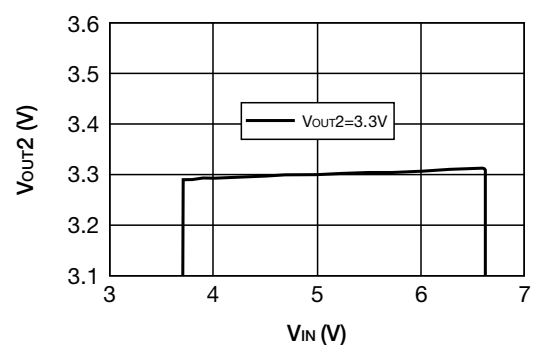

• Any products mentioned in this catalog are subject to any modification in their appearance and others for improvements without prior notification.
 • The details listed here are not a guarantee of the individual products at the time of ordering. When using the products, you will be asked to check their specifications.

Supply current - Input voltage

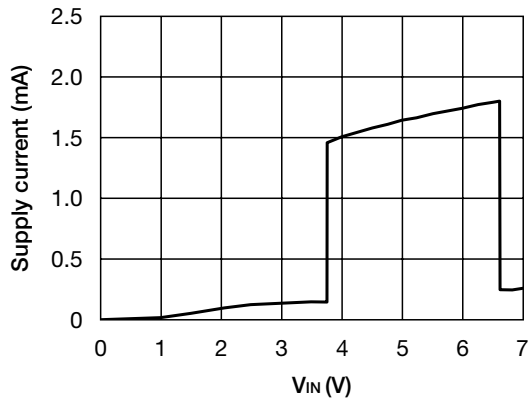

Output Voltage - Temperature (1)

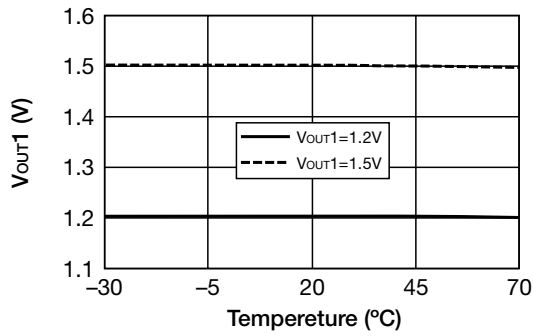

Output Voltage - Temperature (2)

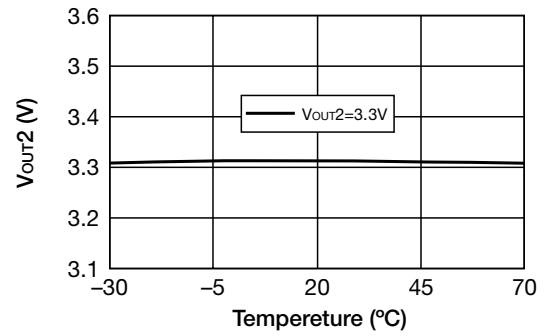

Oscillator Frequency - Temperature

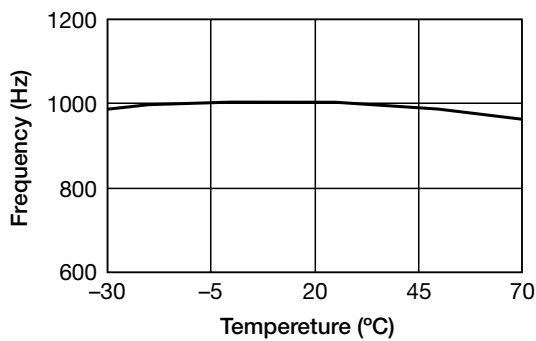

Supply Current - Temperature

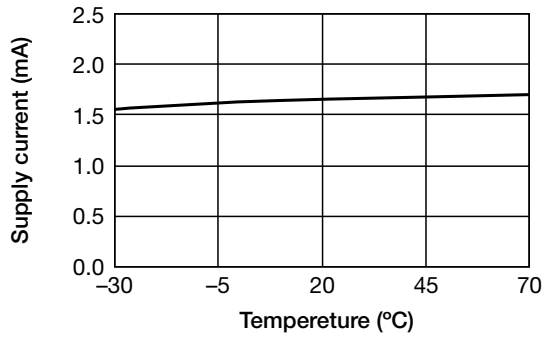

Soft Start

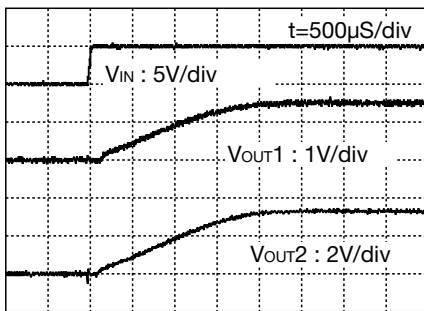

- $V_{IN}=0V \rightarrow 5V$
- $SELV_{OUT1}=0V$

Reset Output
(1) Reset Detection

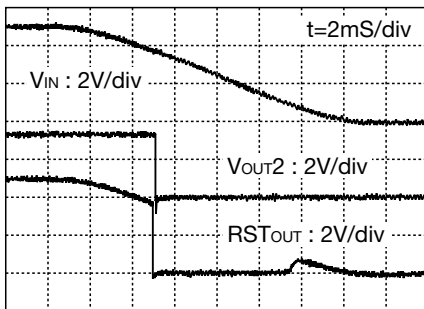

Reset Output
(2) Reset Release

