

500mA Regulator IC Monolithic IC MM3413

Outline

This IC is the series regulator that has been developed to be the best choice for stationary as well as mobile equipment in which power consumption shall be reduced when the power is off or the equipment is in its standby mode. The regulator can output the maximum current of 500mA.

This product has a chip enable function to allow further reduction of consumption current.

Features

- | | |
|-----------------------------|--|
| 1. No load input current : | 45 μ A typ. |
| 2. Input current (OFF) : | 0.1 μ A typ. |
| 3. High ripple rejection : | 70dB / 1kHz |
| 4. Output capacitor : | Compatible with 1 μ F ceramic capacitor |
| 5. Protection circuit : | Current limit circuit and thermal shutdown circuit |
| 6. Current limit circuit | |
| 7. Thermal shutdown circuit | |

Package

SOT89-5A

Applications

1. Portable equipments
2. Electric products for home use

Block Diagram

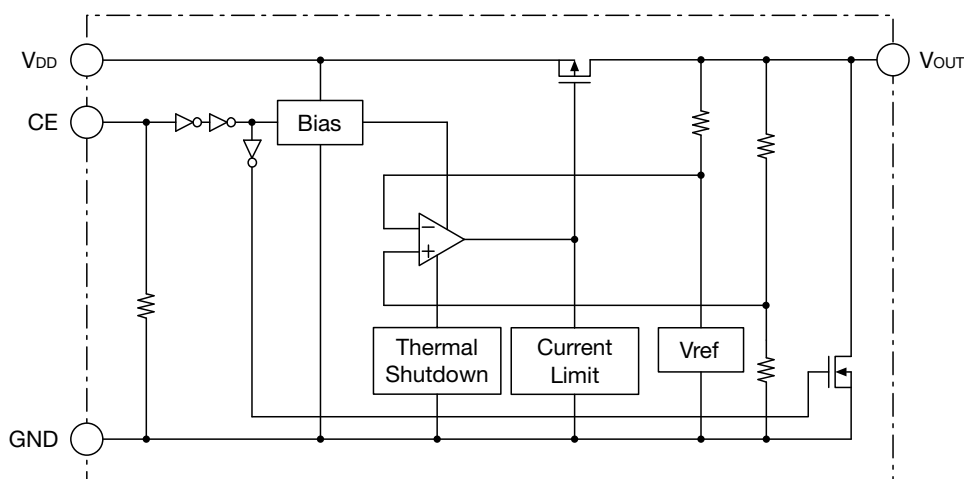

Pin Assignment

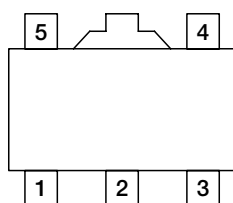

SOT89-5A
(TOP VIEW)

1	CE
2	GND
3	NC
4	V _{OUT}
5	V _{DD}

Pin Description

Pin No.	Pin name	Functions	Internal equivalent circuit						
1	CE	ON/OFF-Control pin <table border="1"> <tr> <td>CE</td> <td>V_{OUT}</td> </tr> <tr> <td>L</td> <td>OFF</td> </tr> <tr> <td>H</td> <td>ON</td> </tr> </table> Connect CE pin with V _{DD} pin, when it is not used.	CE	V _{OUT}	L	OFF	H	ON	Please refer to BLOCK DIAGRAM.
CE	V _{OUT}								
L	OFF								
H	ON								
2	GND	GND pin							
3	NC	No connection							
4	V _{OUT}	Output pin							
5	V _{DD}	Voltage-Supply pin							

• Any products mentioned in this catalog are subject to any modification in their appearance and others for improvements without prior notification.
 • The details listed here are not a guarantee of the individual products at the time of ordering. When using the products, you will be asked to check their specifications.

Absolute Maximum Ratings (Except where noted otherwise Ta=25°C)

Item	Symbol	Ratings	Units
Storage Temperature	T _{stg}	-55~+150	°C
Supply Voltage	V _{DD}	6.5	V
CE Input Voltage	V _{CE}	-0.3~V _{DD} +0.3	V
Output Voltage	V _{OUT}	-0.3~V _{DD} +0.3	V
Output Current	I _{omax}	600	mA
Power Dissipation	P _d	690 (Note1)	mW

Note1 : With the PC Board of glass epoxy. (50 × 50 × 1.6^tmm)

Recommended Operating Conditions (Except where noted otherwise Ta=25°C)

Item	Symbol	Ratings	Units
Operating Ambient Temperature	T _{jop}	-40~+85	°C
Operating Voltage	V _{op}	2~6	V
Output Current	I _o	0~500	mA

Electrical Characteristics 1 (Except where noted otherwise V_{DD}=V_O(typ.)+1V, V_{CE}=V_{DD}, Ta=25°C)

Item	Symbol	Measurement conditions	Min.	Typ.	Max.	Units
Input Current(OFF)	I _{DDoff}	V _{CE} =0V		0.1	1.0	μA
No-Load Input Current	I _{DD}	I _{OUT} =0mA		45	70	μA
Output Voltage	V _{OUT}	I _{OUT} =30mA	×0.99		×1.01	V
Line Regulation	V _{LINE}	V _{DD} =V _O (typ.)+0.5~6V, I _{OUT} =30mA (V _{OUT} ≤1.6V, V _{DD} =2.2~6V)		0.02	0.10	%/V
Load Regulation	V _{LOAD}	1mA≤I _{OUT} ≤500mA		50	140	mV
Dropout Voltage	V _{io}	Please refer to another page				V
Ripple Rejection 1 (Note2)	RR1	f=1kHz, V _{ripple} =0.5V, I _{OUT} =30mA (V _{OUT} ≤1.7V, V _{DD} =V _{OUT} +1.2V)		70		dB
Ripple Rejection 2 (Note2)	RR2	f=10kHz, V _{ripple} =0.5V, I _{OUT} =30mA (V _{OUT} ≤1.7V, V _{DD} =V _{OUT} +1.2V)		50		dB
V _{OUT} Temperature Coefficient (Note2)	ΔV _{OUT} /ΔT	I _{OUT} =30mA -40°C≤T _{OP} ≤+85°C		±100		ppm/°C
Output Noise Voltage (Note2)	V _n	f _{BW} =10~100kHz I _{OUT} =30mA		30		μV _{rms}
Output Short-circuit Current (Note2)	I _{lim}	V _{OUT} =0V		40		mA
CE Pull-down Resistance	R _{pd}		0.7	2	8	MΩ
CE High Threshold Voltage	V _{CEH}		1.5		V _{DD}	V
CE Low Threshold Voltage	V _{CEL}		0		0.3	V
Output NMOS ON resistance	R _{DON}	V _{CE} =0V V _{DD} =4V(V _{OUT} <3V)		30		Ω

Note2 : The parameter is guaranteed by design.

Electrical Characteristics 2 (Except where noted otherwise $V_{DD}=V_{OUT}(typ.)+1V$, $V_{CE}=V_{DD}$, $T_a=25^{\circ}C$)

Output Voltage V_{o1}	Item							
	Output Voltage				Dropout Voltage			
	V_o (V)				V_{io} (V)			
	Measurement Conditions	Min.	Typ.	Max.	Measurement Conditions	Min.	Typ.	Max.
1.5V	$I_{out}=30mA$	1.485	1.5	1.515	(Note3)			
1.6V		1.584	1.6	1.616				
1.7V		1.683	1.7	1.717				
1.8V		1.782	1.8	1.818				
1.9V		1.881	1.9	1.919				
2.0V		$2.0V \leq V_o \leq 2.7V$ $I_o=500mA$	1.980	2.0	2.020		0.40	0.62
2.1V			2.079	2.1	2.121			
2.2V			2.178	2.2	2.222			
2.3V			2.277	2.3	2.323			
2.4V			2.376	2.4	2.424			
2.5V			2.475	2.5	2.525			
2.57V			2.544	2.57	2.596			
2.6V			2.574	2.6	2.626			
2.7V			2.673	2.7	2.727			
2.8V			2.772	2.8	2.828			
2.9V		2.871	2.9	2.929	$2.5V \leq V_o \leq 5.0V$ $I_o=500mA$		0.28	0.46
3.0V		2.970	3.0	3.030				
3.1V		3.069	3.1	3.131				
3.2V		3.168	3.2	3.232				
3.3V		3.267	3.3	3.333				
3.4V	3.366	3.4	3.434					
3.5V	3.465	3.5	3.535					
3.6V	3.564	3.6	3.636					
3.7V	3.663	3.7	3.737					
3.8V	3.762	3.8	3.838					
3.9V	3.861	3.9	3.939					
4.0V	3.960	4.0	4.040					
4.1V	4.059	4.1	4.141					
4.2V	4.158	4.2	4.242					
4.3V	4.257	4.3	4.343					
4.4V	4.356	4.4	4.444					
4.5V	4.455	4.5	4.545					
4.6V	4.554	4.6	4.646					
4.7V	4.653	4.7	4.747					
4.8V	4.752	4.8	4.848					
4.9V	4.851	4.9	4.949					
5.0V	4.950	5.0	5.050					

Note3 : The parameter is not guaranteed in the model less than $V_o=2.0$.

• Any products mentioned in this catalog are subject to any modification in their appearance and others for improvements without prior notification.
 • The details listed here are not a guarantee of the individual products at the time of ordering. When using the products, you will be asked to check their specifications.

Measuring Circuit

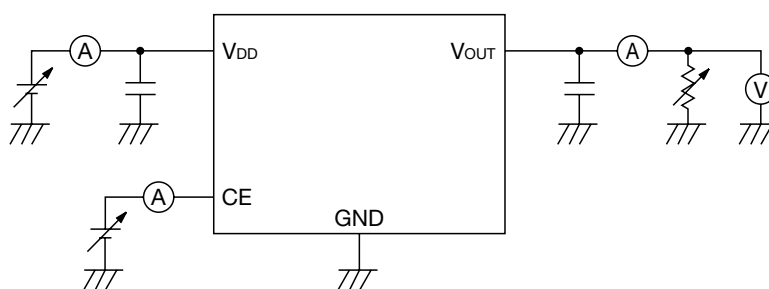

Application Circuit

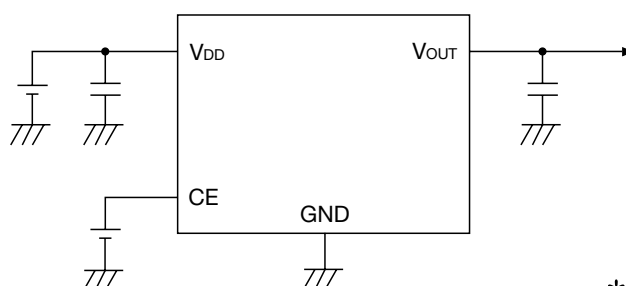

* Temperature Characteristics : B

(Reference example of external parts)

- Output capacitor Ceramic capacitor 1 μ F
- Input capacitor Ceramic capacitor 1 μ F

· Note

1. The output capacitor is required between output and GND to prevent oscillation.
2. The ESR of capacitor must be defined in ESR stability area.
It is possible to use a ceramic capacitor without ESR resistance for output.
The ceramic capacitor must be used more than 1.0 μ F and B temperature characteristics.
3. The wire of Vcc and GND is required to print full ground plane for noise and stability.
4. The input capacitor must be connected a distance of less than 1cm from input pin.
5. In case the output voltage is above the input voltage, the overcurrent flow by internal parastic diode from output to input.

Characteristics (Vo=1.5V) (Except where noted otherwise $V_{DD}=V_{OUT}(typ.)+1V$, $V_{CE}=V_{DD}$, $T_a=25^{\circ}C$)

Output - Input voltage

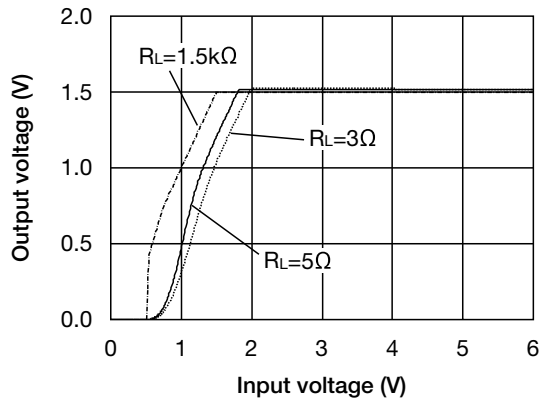

Input current - Input voltage

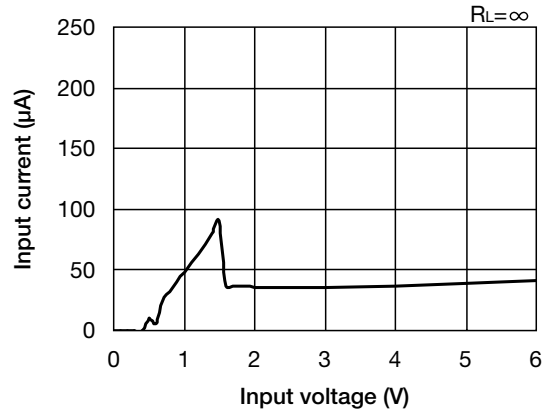

Output voltage - Output current

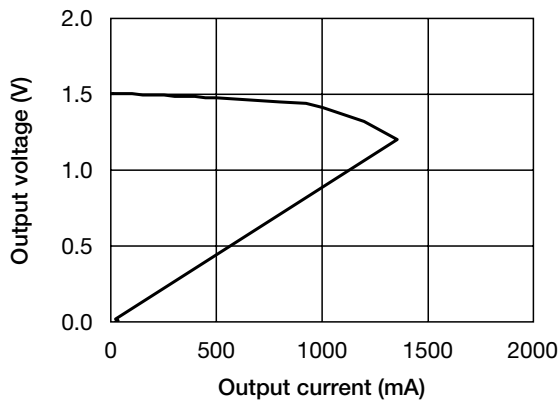

Load regulation

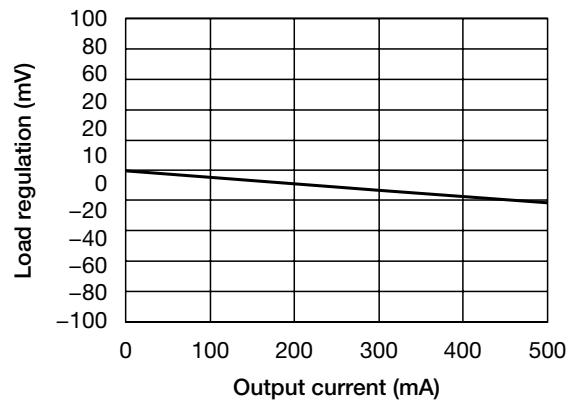

Line regulation

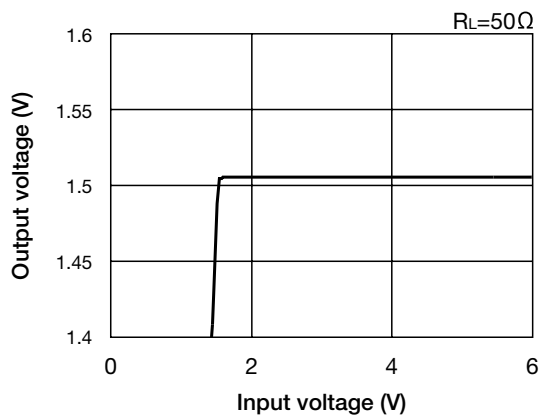

Output voltage - Ambient temperature

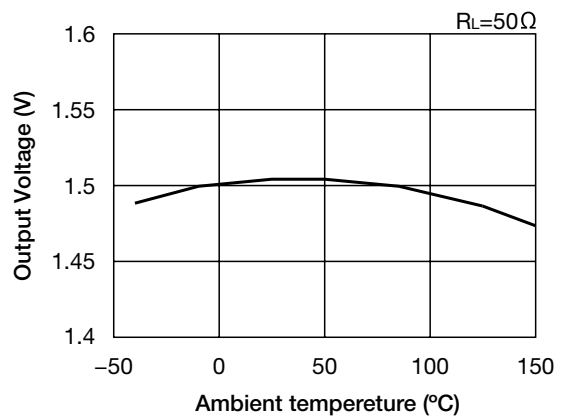

• Any products mentioned in this catalog are subject to any modification in their appearance and others for improvements without prior notification.
 • The details listed here are not a guarantee of the individual products at the time of ordering. When using the products, you will be asked to check their specifications.

Ripple Rejection

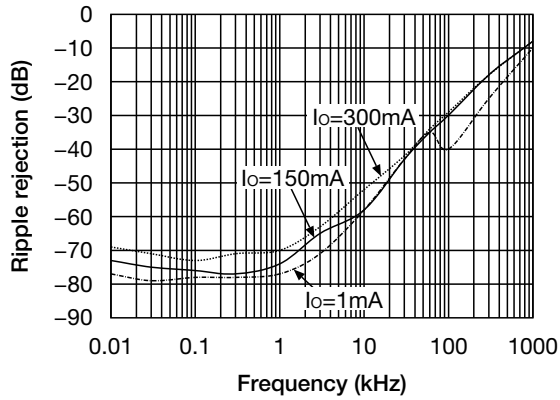

ESR Stable area

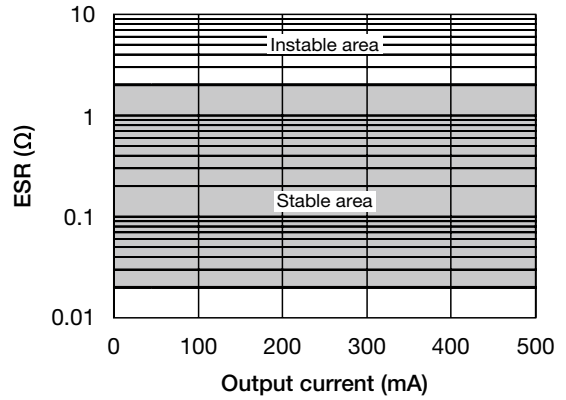

Load transient response ($I_o = 10 \rightarrow 500\text{mA}$)

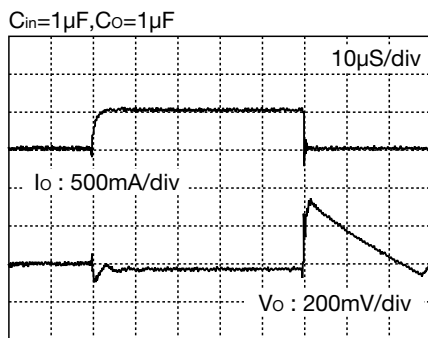

Turn-On transient response

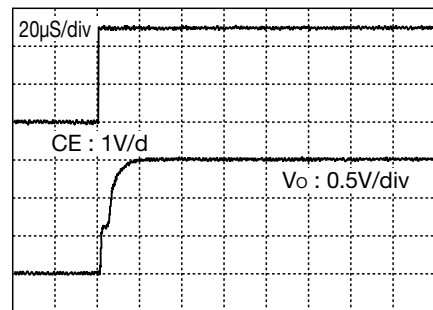

Thermal Shutdown

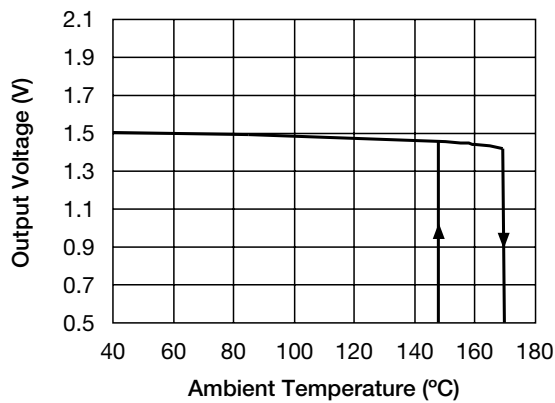

Characteristics (Vo=3.0V) (Except where noted otherwise $V_{DD}=V_{OUT}(typ.)+1V$, $V_{CE}=V_{DD}$, $T_a=25^{\circ}C$)

Output - Input voltage

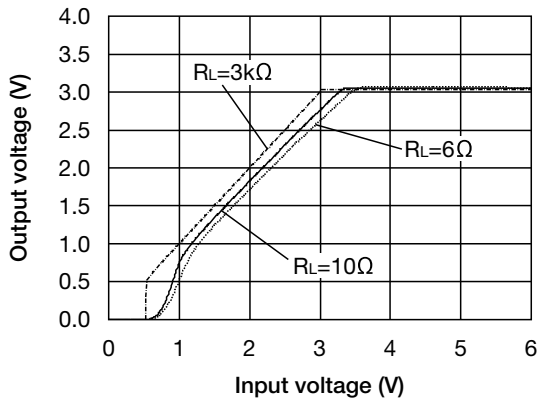

Input current - Input voltage

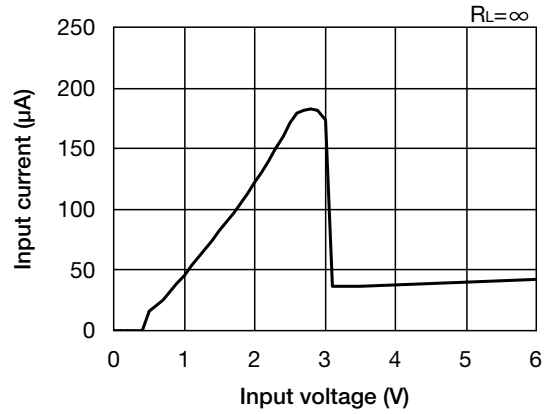

Output voltage - Output current

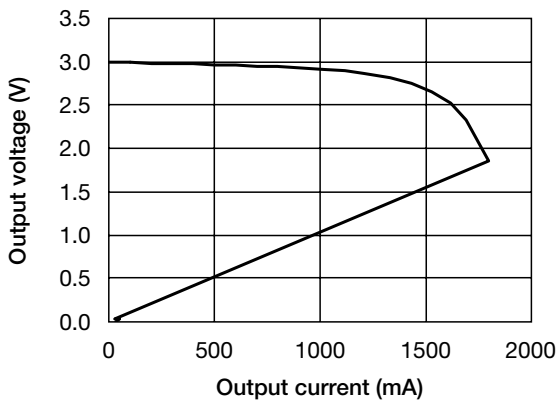

Load regulation

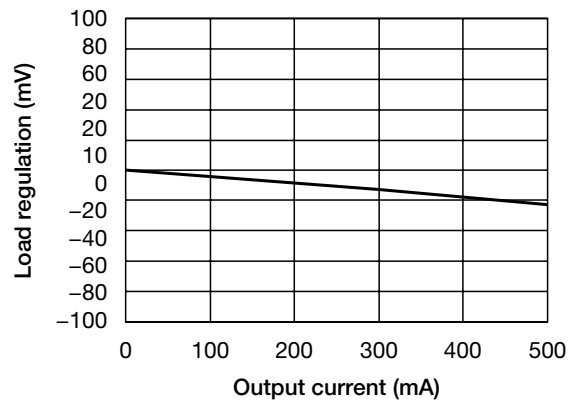

Line regulation

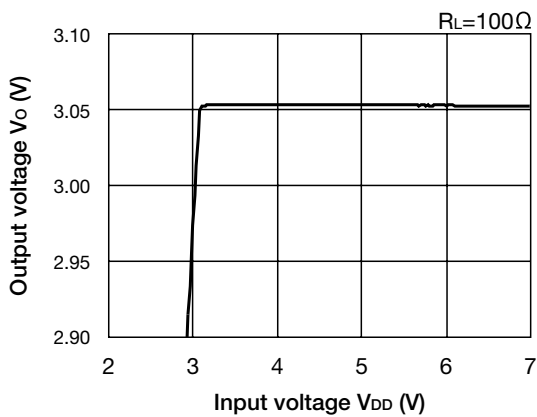

Dropout voltage

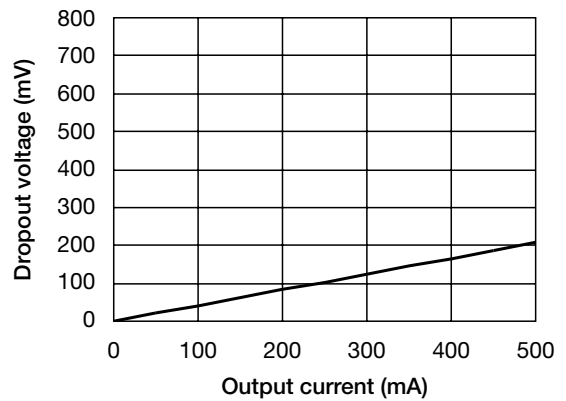

• Any products mentioned in this catalog are subject to any modification in their appearance and others for improvements without prior notification.
 • The details listed here are not a guarantee of the individual products at the time of ordering. When using the products, you will be asked to check their specifications.

Ripple Rejection

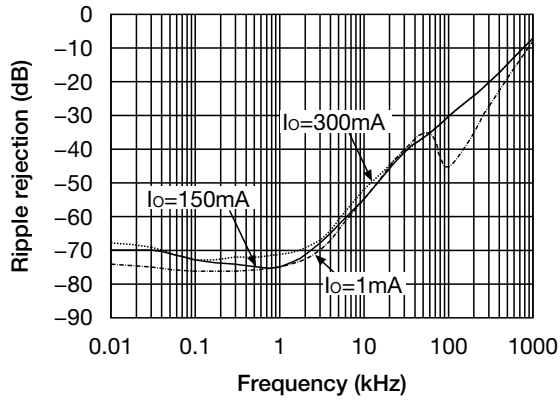

Output voltage - Ambient temperature

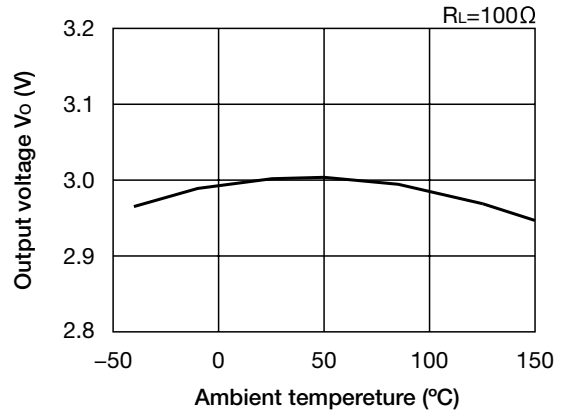

Load transient response ($I_o = 10 \rightarrow 500\text{mA}$)

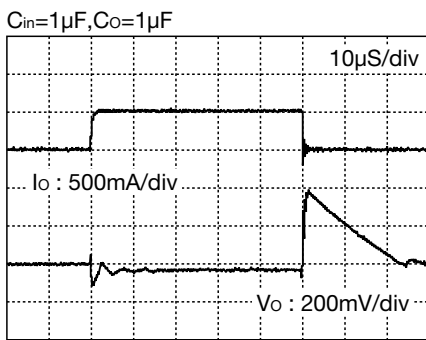

Turn-On transient response

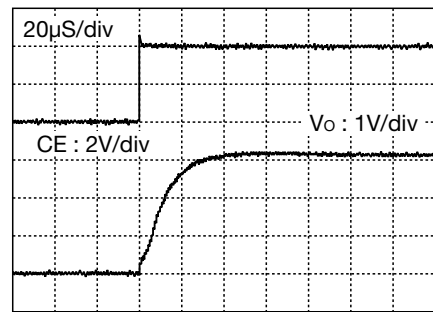

ESR Stable area

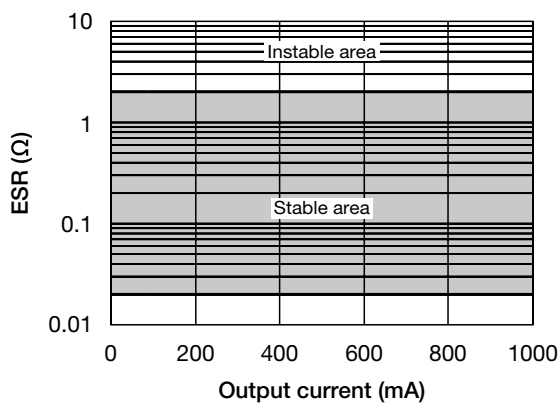

Thermal Shutdown

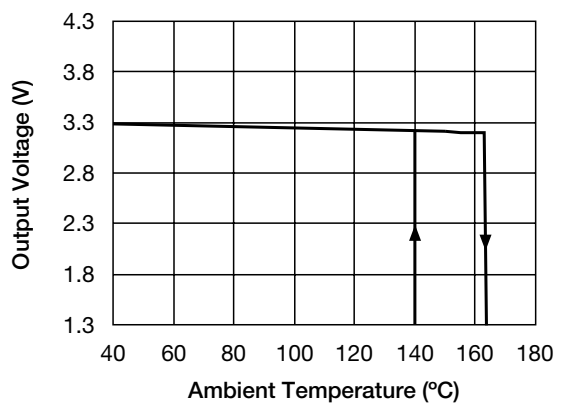

• Any products mentioned in this catalog are subject to any modification in their appearance and others for improvements without prior notification.
 • The details listed here are not a guarantee of the individual products at the time of ordering. When using the products, you will be asked to check their specifications.

Characteristics (Vo=5.0V) (Except where noted otherwise $V_{DD}=V_{OUT}(typ.)+1V$, $V_{CE}=V_{DD}$, $T_a=25^{\circ}C$)

Output - Input voltage

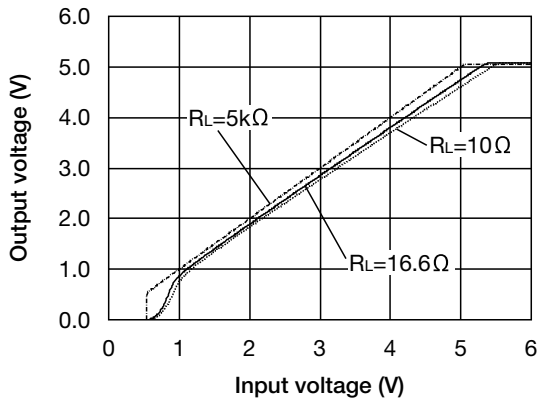

Input current - Input voltage

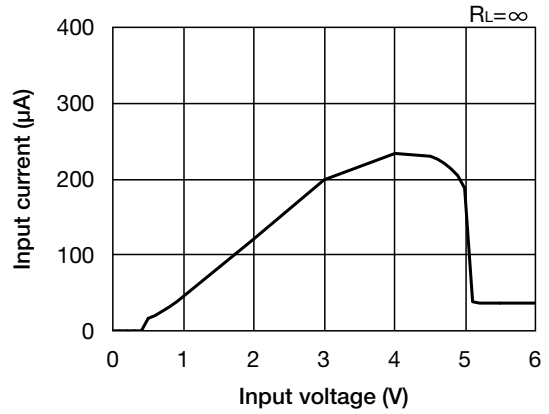

Output voltage - Output current

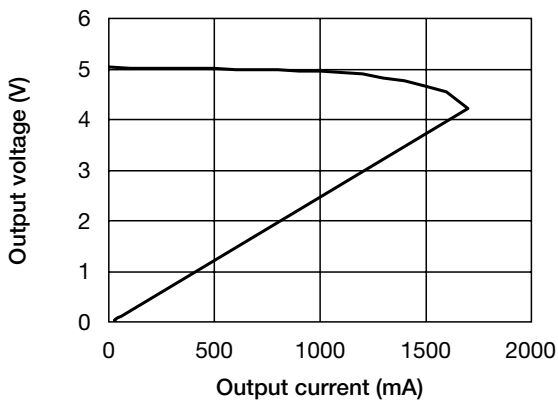

Load regulation

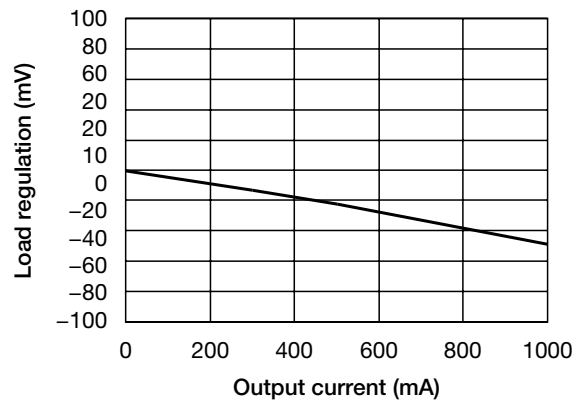

Line regulation

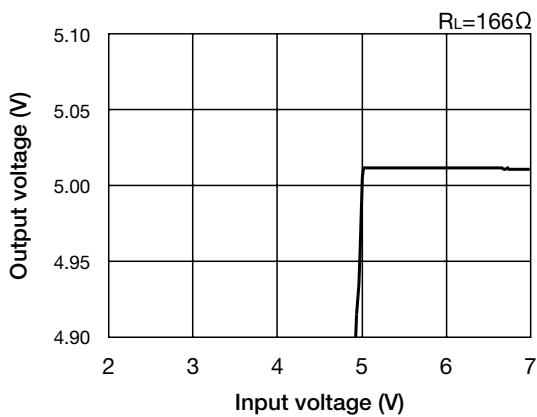

Dropout voltage

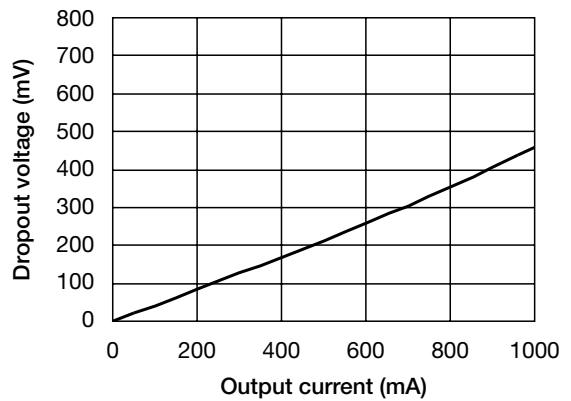

• Any products mentioned in this catalog are subject to any modification in their appearance and others for improvements without prior notification.
 • The details listed here are not a guarantee of the individual products at the time of ordering. When using the products, you will be asked to check their specifications.

Ripple Rejection

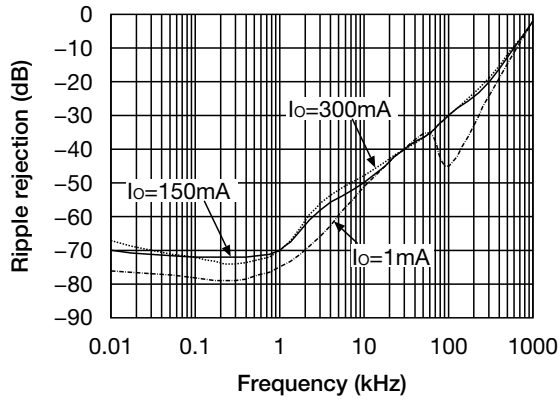

Output voltage - Ambient temperature

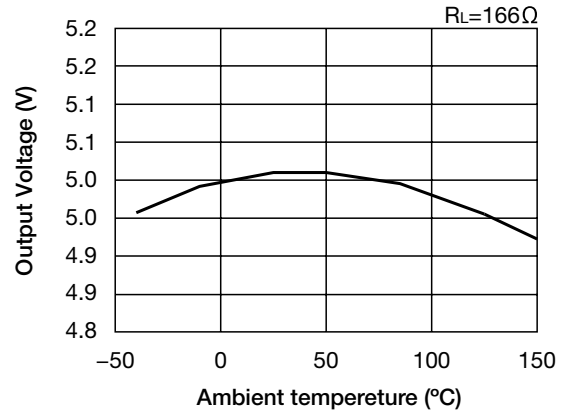

Load transient response ($I_o = 10 \rightarrow 500\text{mA}$)

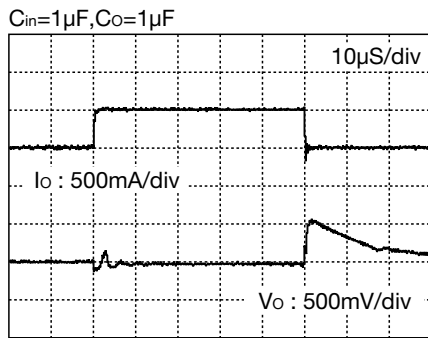

Turn-On transient response

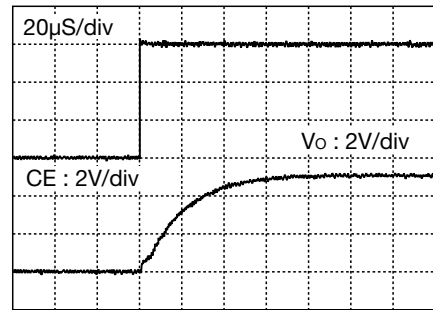

ESR Stable area

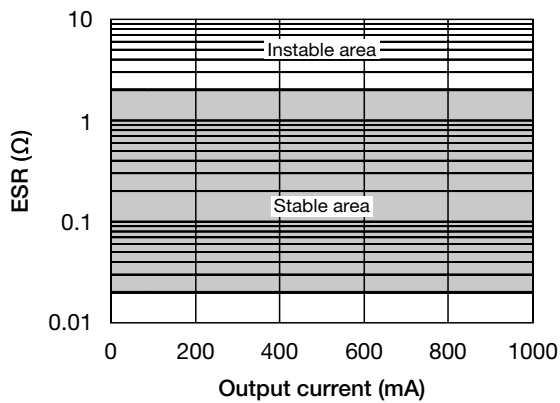

Thermal Shutdown

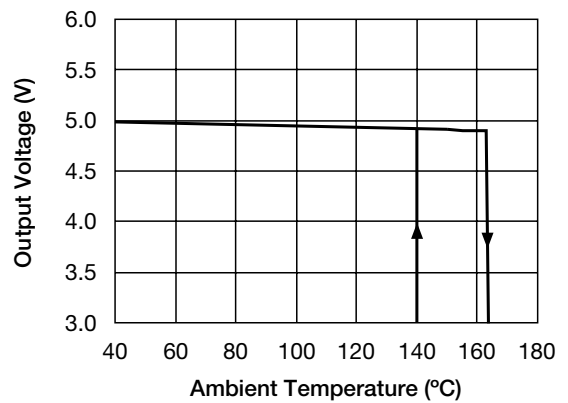

• Any products mentioned in this catalog are subject to any modification in their appearance and others for improvements without prior notification.
 • The details listed here are not a guarantee of the individual products at the time of ordering. When using the products, you will be asked to check their specifications.