

200mA LDO with reverse bias protection Monolithic IC MM1839 Series

Outline

This IC is a 200mA LDO with a reverse bias protection function.

The IC applies to a standard home equipments, for a maximum operating voltage is 14V.

In addition, a protection diode is not necessary because a reverse bias protection function is built in it.

Features

1. Maximum operating voltage	14V
2. Output current	200mA
3. No load input current	85 μ A typ.
4. Input current(OFF)	1 μ A max.
5. Output voltage range	1.5~5.0V
6. Output voltage accuracy	\pm 2%
7. Dropout voltage	300mV typ. (I _o =200mA)
8. Line regulation	0.1%/V max.
9. Load regulation	60mV max. (I _o =1~200mA)
10. Ripple rejection	70dB typ. (f=1kHz)
11. Output Capacitor	1 μ F
12. ON/OFF control	
13. Thermal shutdown	

Package

SOT-25A
SSON-6E

Applications

1. TV
2. BD recorder
3. Printer
4. Game

Block Diagram

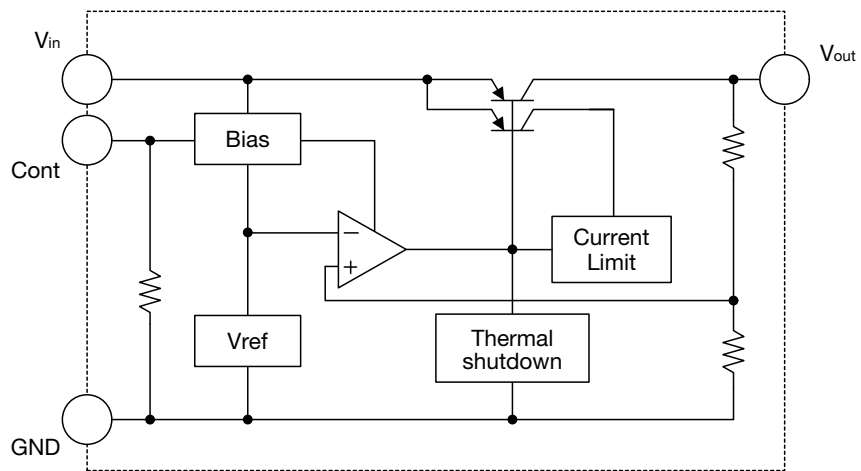

Pin Assignment

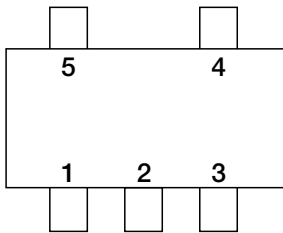

SOT-25A
(TOP VIEW)

1	Cont
2	GND
3	NC
4	Vout
5	Vin

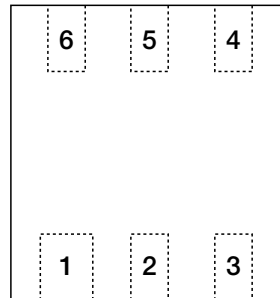

SSON-6E
(TOP VIEW)

1	NC
2	GND
3	Cont
4	Vin
5	NC
6	Vout

Pin Description

SOT-25A

Pin No.	Pin name	Functions	Internal equivalent circuit diagram						
1	Cont	<p>ON/OFF-CONTROL PIN</p> <table border="1"> <tr> <td>CE</td> <td>OUTPUT</td> </tr> <tr> <td>L</td> <td>OFF</td> </tr> <tr> <td>H</td> <td>ON</td> </tr> </table> <p>Connect Cont pin with V_{DD} pin, when it is not used.</p>	CE	OUTPUT	L	OFF	H	ON	
CE	OUTPUT								
L	OFF								
H	ON								
2	GND	GND PIN							
3	NC	NO CONNECTION							
4	Vout	<p>OUTPUT PIN</p> <p>The output capacitor is recommended 1μF. The IC incorporates an overcurrent protection circuit for reverse voltage between input and output.</p>							
5	Vin	VOLTAGE-SUPPLY PIN							

SSON-6E

Pin No.	Pin name	Functions	Internal equivalent circuit diagram						
1, 5	NC	NO CONNECTION							
2	GND	GND PIN							
3	Cont	<p>ON/OFF-CONTROL PIN</p> <table border="1"> <tr> <td>CE</td> <td>OUTPUT</td> </tr> <tr> <td>L</td> <td>OFF</td> </tr> <tr> <td>H</td> <td>ON</td> </tr> </table> <p>Connect Cont pin with V_{DD} pin, when it is not used.</p>	CE	OUTPUT	L	OFF	H	ON	
CE	OUTPUT								
L	OFF								
H	ON								
4	Vin	VOLTAGE-SUPPLY PIN							
6	Vout	<p>OUTPUT PIN</p> <p>The output capacitor is recommended 1μF. The IC incorporates an overcurrent protection circuit for reverse voltage between input and output.</p>							

• Any products mentioned in this catalog are subject to any modification in their appearance and others for improvements without prior notification.
• The details listed here are not a guarantee of the individual products at the time of ordering. When using the products, you will be asked to check their specifications.

Absolute Maximum Ratings (Except where noted otherwise Ta=25°C)

Item	Symbol	Ratings		Units
Storage Temperature	T _{stg}	-55~150		°C
Junction Temperature	T _{jMAX}	150		°C
Supply Voltage	V _{DD}	-0.3~16.0	SOT-25A	V
		-0.3~15.0	SSON-6E	
CE input Voltage	V _{CE}	-0.3~16.0	SOT-25A	V
		-0.3~15.0	SSON-6E	
Input - Output Reverse Voltage	V _{rio}	10.0	SOT-25A	V
		6.0	SSON-6E	
Output Current	I _{omax}	0~300		mA
Power Dissipation1	Pd1	350(Note1)	SOT-25A	mW
		170(Note3)	SSON-6E	
Power Dissipation2	Pd2	700(Note2)	SOT-25A	mW
		900(Note4)	SSON-6E	

Note1 : With the PC Board of glass epoxy. (60 × 40 × 1.6mm)

Note2 : JEDEC51-7 standard (114.3 × 76.2 × 1.6mm)

Note3 : Alone

Note4 : With the PC Board of glass epoxy. (25 × 25 × 1.6mm)

Recommended Operating Conditions (Except where noted otherwise Ta=25°C)

Item	Symbol	Ratings	Units
Operating Ambient Temperature	T _{opr}	-40~85	°C
Operating Voltage	V _{op}	1.8~14	V
Output Current	I _{op}	0~200	mA

Electrical Characteristics 1 (Except where noted otherwise VDD=VOUT(TYP.)+1V, VCE=VDD, Ta=25°C)

Item	Symbol	Measurement conditions	Min.	Typ.	Max.	Units
Input Current(OFF)	I _{DDoff}	V _{CE} =0V		0.00	1.0	μA
No-Load Input Current	I _{DD}	I _{OUT} =0mA		85	140	μA
Output Voltage (Note2)	V _{OUT}	I _{OUT} =1mA	×0.98		×1.02	V
Dropout Voltage (Note3)	V _{io}	V _{in} =V _o -0.2V, I _o =200mA		0.3	0.5	V
Line Regulation	ΔV1	V _{in} =V _o +1~14V, I _o =1mA			0.1	%/V
Load Regulation	ΔV2	I _o =1~200mA		15	60	mV
Vout Temperature Coefficient (Note1)	ΔVout/ΔT	-40≤T _{OP} ≤85°C	SOT-25A	100		ppm/°C
		V _{OUT} (TYP.)+0.5≤V _{DD} ≤6.5V -40≤T _{OP} ≤85°C	SSON-6E			
Ripple Rejection (Note1)	RR	f=1kHz V _{ripple} =0.2V _{p-p} , I _{OUT} =10mA	SOT-25A	70		dB
		f=1kHz V _{ripple} =1V _{p-p} , I _{OUT} =10mA	SSON-6E			
Cont Pin Input Current	I _{cont}	V _{cont} =1.6V		3	12	μA
Cont Pin High Threshold Level	V _{contH}		1.6			V
Cont Pin Low Threshold Level	V _{contL}				0.3	V

Note1 : The parameter is guaranteed by design.

Note2 : Please refer to another page.

Note3 : The parameter is not guaranteed in the model less than VOUT=2V.

Electrical Characteristics 2 (Except where noted otherwise VDD=VOUT(TYP.)+1V, VCE=VDD, Ta=25°C)

Model No.	Item			
	Output Voltage			
	V _{OUT} (V)			
	Measurement Conditions	Min.	Typ.	Max.
MM1839A15	I _{OUT} =1mA	1.470	1.500	1.530
MM1839A16		1.568	1.600	1.632
MM1839A17		1.666	1.700	1.734
MM1839A18		1.764	1.800	1.836
MM1839A19		1.862	1.900	1.938
MM1839A20		1.960	2.000	2.040
MM1839A21		2.058	2.100	2.142
MM1839A22		2.156	2.200	2.244
MM1839A23		2.254	2.300	2.346
MM1839A24		2.352	2.400	2.448
MM1839A25		2.450	2.500	2.550
MM1839A26		2.548	2.600	2.652
MM1839A27		2.646	2.700	2.754
MM1839A28		2.744	2.800	2.856
MM1839A29		2.842	2.900	2.958
MM1839A30		2.940	3.000	3.060
MM1839A31		3.038	3.100	3.162
MM1839A32		3.136	3.200	3.264
MM1839A33		3.234	3.300	3.366
MM1839A34		3.332	3.400	3.468
MM1839A35		3.430	3.500	3.570
MM1839A36		3.528	3.600	3.672
MM1839A37		3.626	3.700	3.774
MM1839A38		3.724	3.800	3.876
MM1839A39		3.822	3.900	3.978
MM1839A40		3.920	4.000	4.080
MM1839A41		4.018	4.100	4.182
MM1839A42		4.116	4.200	4.284
MM1839A43		4.214	4.300	4.386
MM1839A44		4.312	4.400	4.488
MM1839A45		4.410	4.500	4.590
MM1839A46		4.508	4.600	4.692
MM1839A47		4.606	4.700	4.794
MM1839A48		4.704	4.800	4.896
MM1839A49		4.802	4.900	4.998
MM1839A50	4.900	5.000	5.100	

• Any products mentioned in this catalog are subject to any modification in their appearance and others for improvements without prior notification.
 • The details listed here are not a guarantee of the individual products at the time of ordering. When using the products, you will be asked to check their specifications.

Measuring Circuit

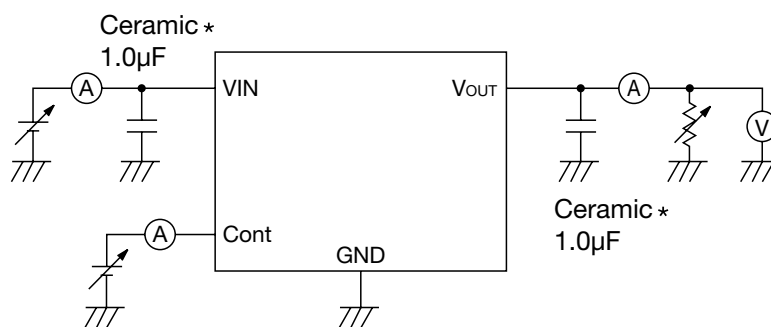

Application Circuit

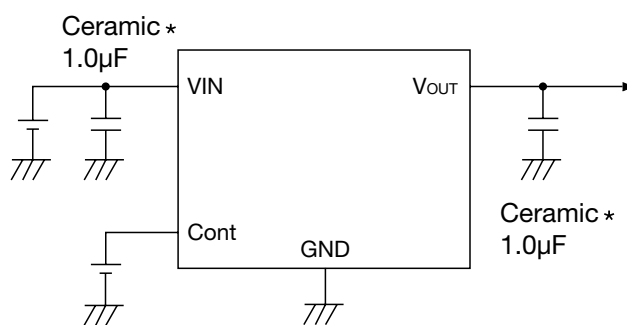

* Temperature Characteristics : B

(Reference example of external parts)

- Output capacitor Ceramic capacitor 1µF
- Input capacitor Ceramic capacitor 1µF

· In the event a problem which may affect industrial property or any other rights of us or a third party is encountered during the use of information described in these circuit, we shall not be liable for any such problem, nor grant a license therefore.

· Note

1. There is a possibility with deterioration and destruction of IC when using it exceeding the absolute maximum rating. The absolute maximum rating, Never exceed it. The functional operation is not assured.
2. There is a possibility that it becomes impossible to maintain this performance and reliability IC original when using it exceeding recommended operation voltage.
Please use it in recommended operation voltage.
3. Due to restrictions on the package power dissipation, the output current value may not be satisfied. Attention should be paid to the power dissipation of the package when the output current is large or the voltage between Iinput and Output is high.
4. The output capacitor is required between output and GND to prevent oscillation.
5. The ESR of capacitor must be defined in ESR stability area. It is possible to use a ceramic capacitor without ESR resistance for output. The ceramic capacitor must be used more than 1.0 μ F and B temperature characteristics.
6. The wire of VDD and GND is required to print full ground plane for noise and stability.
7. The input capacitor must be connected a distance of less than 1cm from input pin.
8. It is able to an unstable operation when you use the capacitor with intense capacitance change
The capacitor has the dependency at the power-supply voltage and the temperature.
The capacity value changes by the environment used. Please evaluate IC in the set.
9. The overcurrent protection circuit of the vertical type is built into this IC.
10. There is a possibility that IC generates heat when the output terminal is short-circuited.
However, the thermal shutdown circuit operates, and it will do operation that protects IC.
The thermal shutdown circuit is designed only to shut the IC off to prevent thermal runaway.
Do not continue to use the IC in an environment where the operation of this circuit is assumed.
The characteristic changes depending on the substrate condition. Please evaluate IC in the set.
11. A reverse bias protection function is built in this IC. When reverse bias occurs, You can use it without protection Diode. The ABSOLUTE MAXIMUM RATINGS of the reverse bias is (MM1839AxxN 10V), (MM1839AxxR 6V).

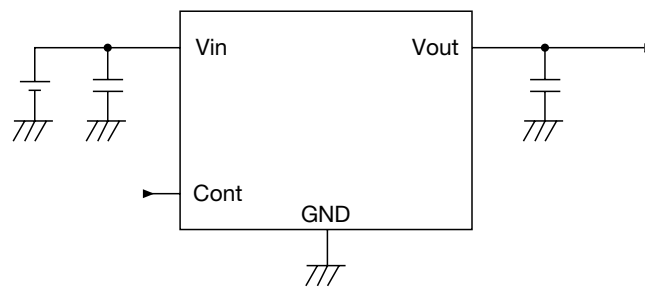

12. It returns automatically in temperature returned after it shuts down by self-generation of heat.
After it returns, it shuts down again by self-generation of heat. It is necessary to change the environment used (IC consumption, temperature) if it operates in upper cycle.
13. Reverse bias protection function
Reverse bias protection is a function that when the reverse bias occurred, the IC does not destroy.
It is not a function that makes the reverse current to be blocked completely.

About Power Dissipation

The Power dissipation change if board to mount IC change because radiative heat fix at board. It is reference data below, Evaluate IC in the set.

MM1839AxxN

1. PC Board of glass epoxy

Board size 60mm×40mm t=1.6mm Copper foil area 60%
 Power dissipation 350mW Ta=25°C

2. JEDEC51-7 standard

Board size 114.3mm×76.2mm t=1.6mm Copper foil area 80%
 Power dissipation 700mW Ta=25°C (It is reference value measured by JEDEC51-7 standard.)

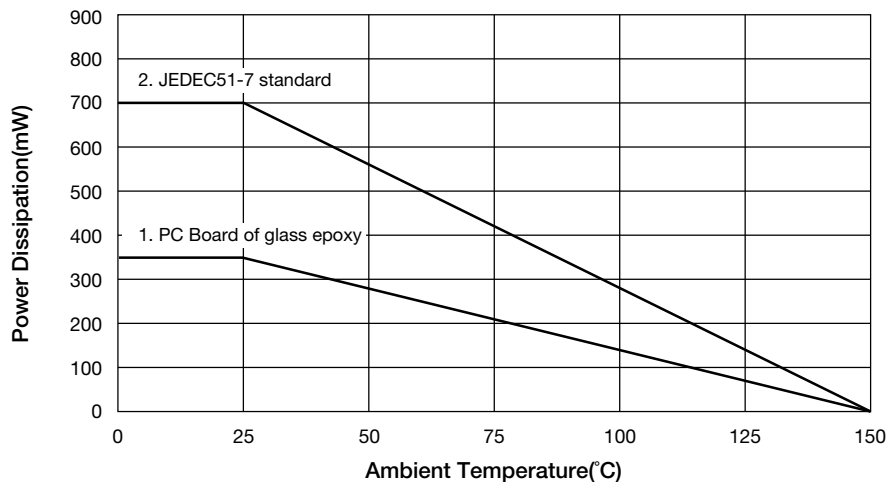

MM1839AxxR

1. Alone

Power dissipation 170mW Ta=25°C

2. PC Board of glass epoxy

Board size 25mm×25mm t=1.6mm Copper foil area 80%
 Power dissipation 900mW Ta=25°C

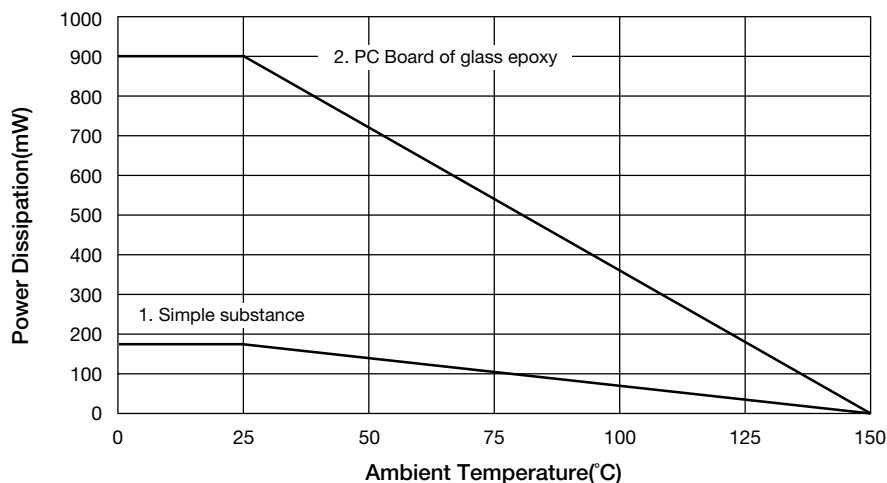

It is recommended to layout the VIA for heat radiation in the GND pattern of reverse (of IC) when there is the GND pattern in the inner layer (in using multi-layer substrate).

By increasing these copper foil pattern area of PCB, Power dissipation improves.

• Any products mentioned in this catalog are subject to any modification in their appearance and others for improvements without prior notification.
 • The details listed here are not a guarantee of the individual products at the time of ordering. When using the products, you will be asked to check their specifications.

Characteristics (Vo=1.5V) (Except where noted otherwise Vin=Vcont=Vo(typ.)+1V, Iout=1mA, Cin=Co=1μF, Ta=25°C)

Input Voltage - Input Current

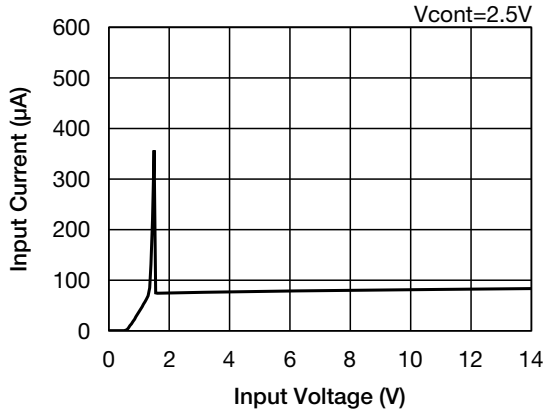

Input Voltage - Input Current

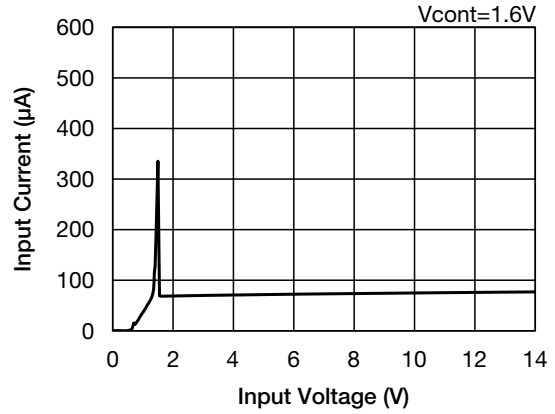

Cont Voltage - Input Current

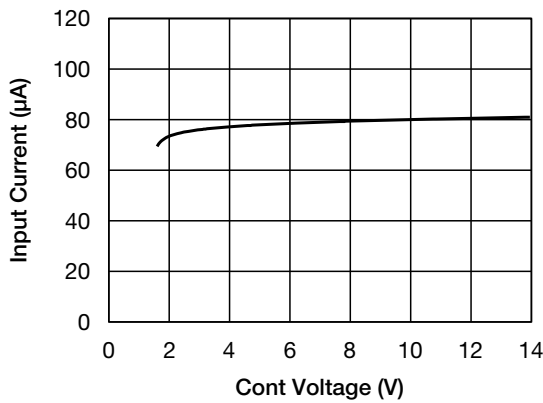

Input Voltage - Output Voltage

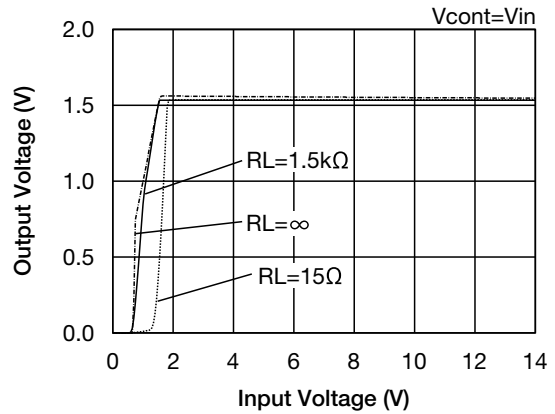

Input Voltage - Output Voltage

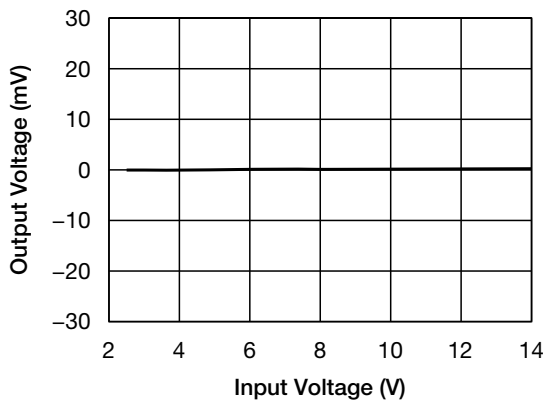

Load Regulation

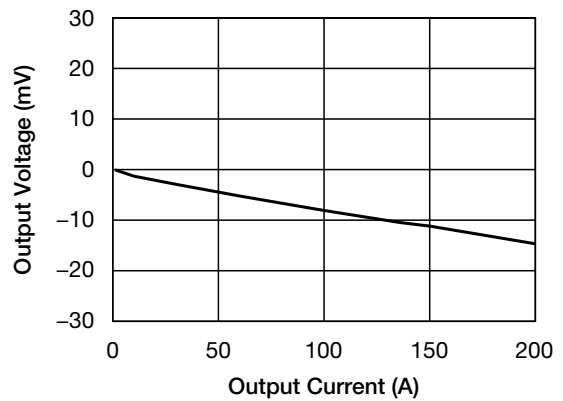

• Any products mentioned in this catalog are subject to any modification in their appearance and others for improvements without prior notification.
 • The details listed here are not a guarantee of the individual products at the time of ordering. When using the products, you will be asked to check their specifications.

■ Cont Voltage - Cont pin Current

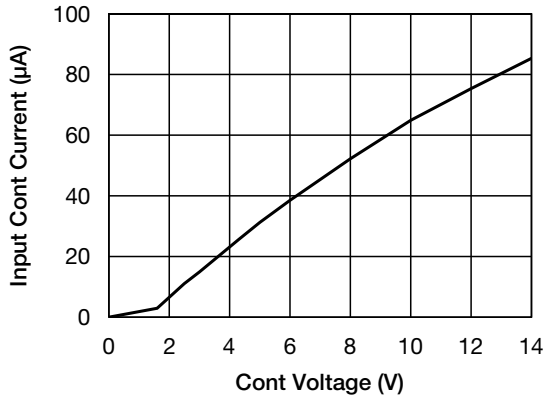

■ Current Limit

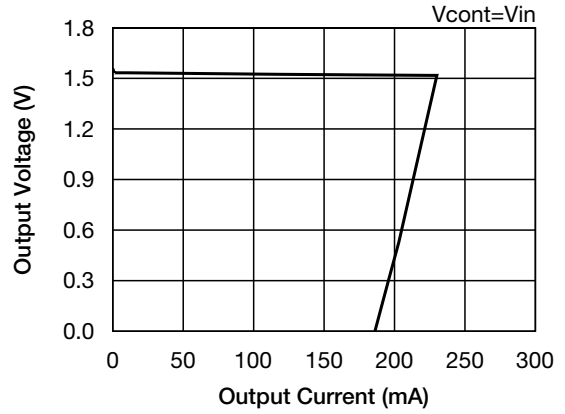

■ Ambient Temperature - Output Voltage

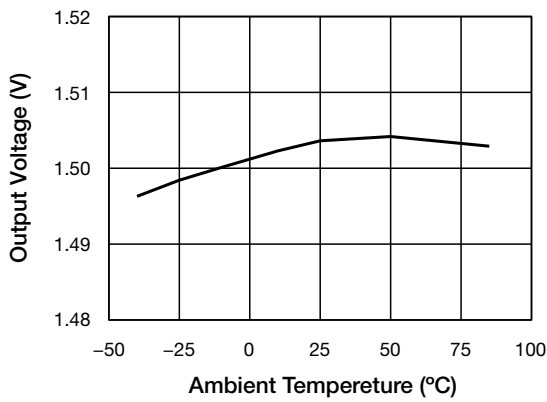

■ Thermal shut down

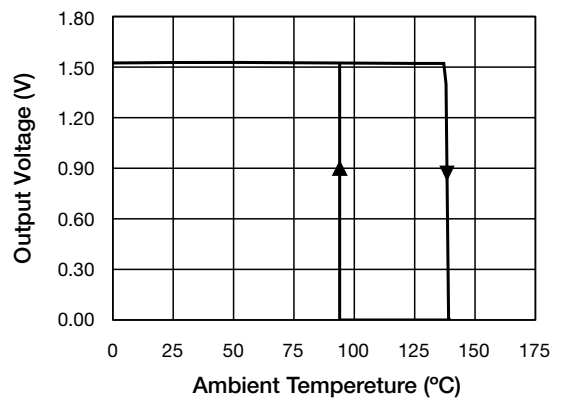

■ Ripple Rejection

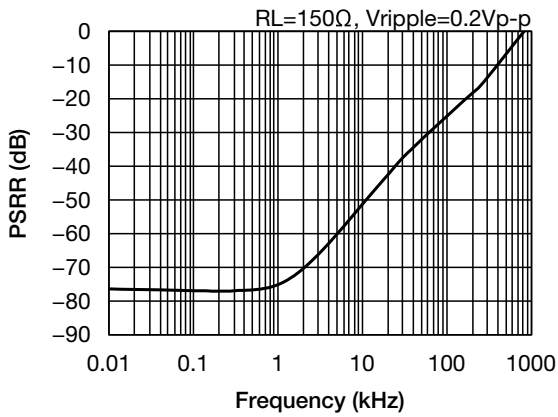

■ ESR stable area

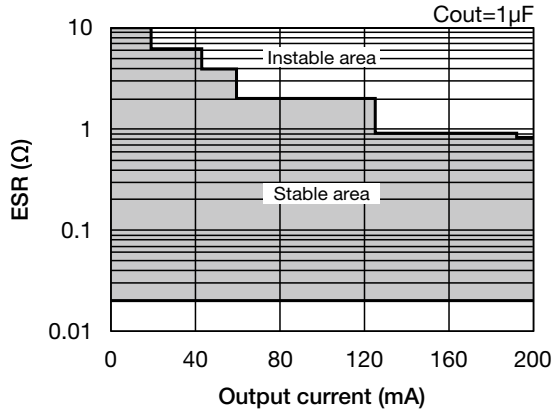

■ ESR stable area

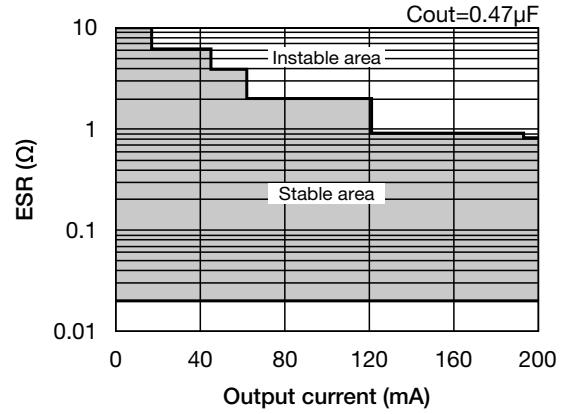

■ Turn-On Transient response

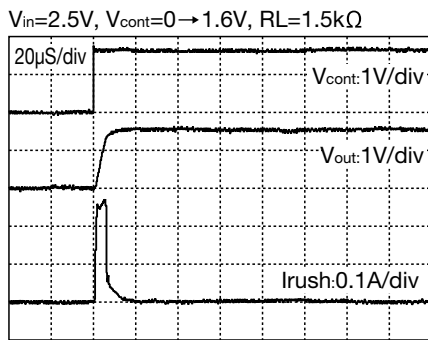

■ Turn-On Transient response

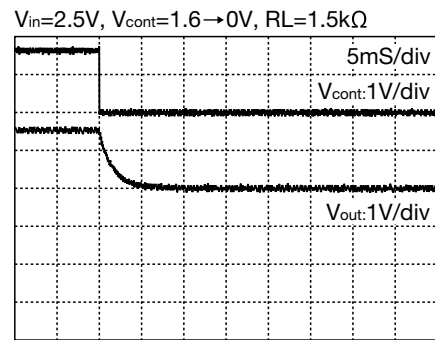

■ Reverse voltage - Reverse current

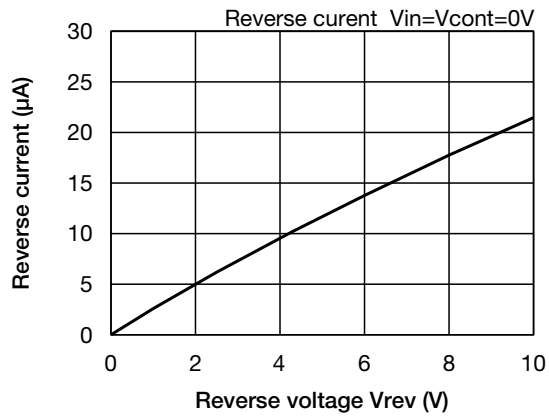

■ Load Transient response

$V_{in}=V_{cout}=2.5V, I_o=1mA \leftrightarrow 50mA, C_{out}=1\mu F$

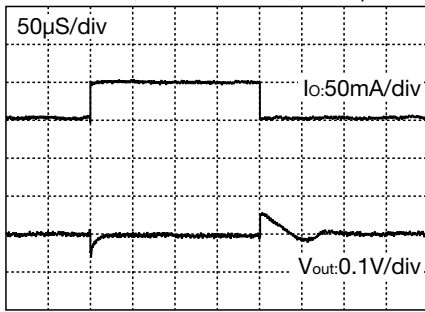

$V_{in}=V_{cout}=2.5V, I_o=1mA \leftrightarrow 50mA, C_{out}=2.2\mu F$

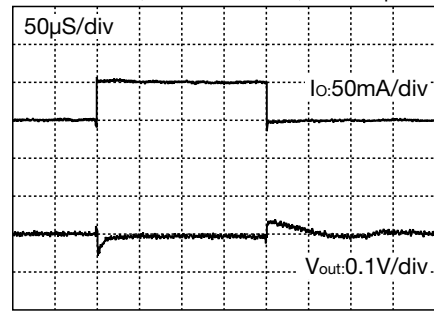

$V_{in}=V_{cout}=2.5V, I_o=1mA \leftrightarrow 100mA, C_{out}=1\mu F$

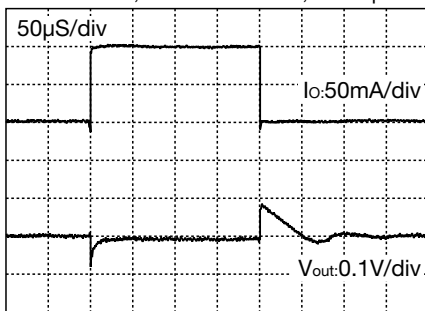

$V_{in}=V_{cout}=2.5V, I_o=1mA \leftrightarrow 100mA, C_{out}=2.2\mu F$

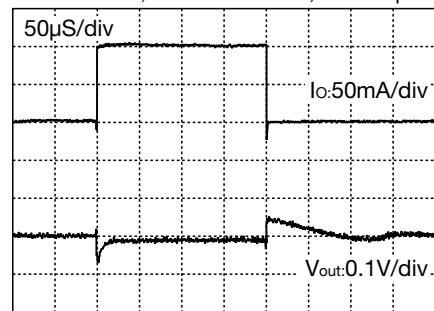

$V_{in}=V_{cout}=2.5V, I_o=1mA \leftrightarrow 200mA, C_{out}=1\mu F$

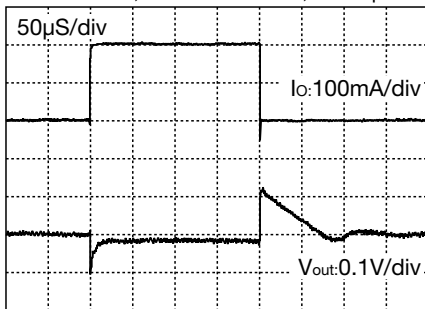

$V_{in}=V_{cout}=2.5V, I_o=1mA \leftrightarrow 200mA, C_{out}=2.2\mu F$

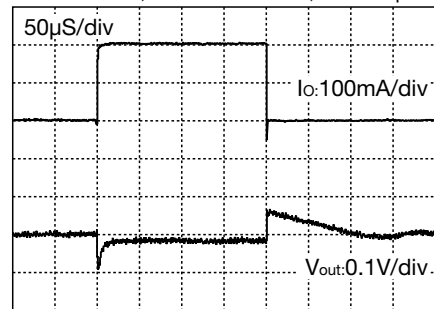

Characteristics (Vo=3.3V) (Except where noted otherwise Vin=Vcont=Vo(typ.)+1V, Iout=1mA, Cin=Co=1μF, Ta=25°C)

Input Voltage - Input Current

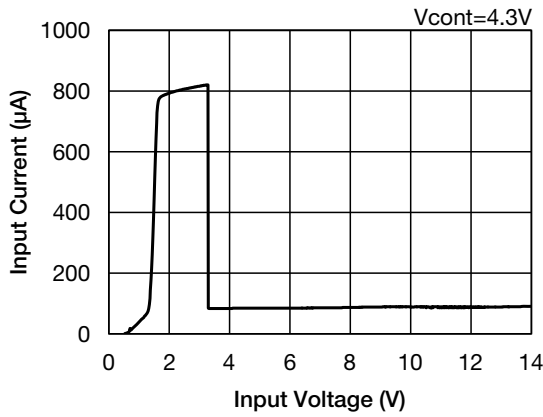

Input Voltage - Input Current

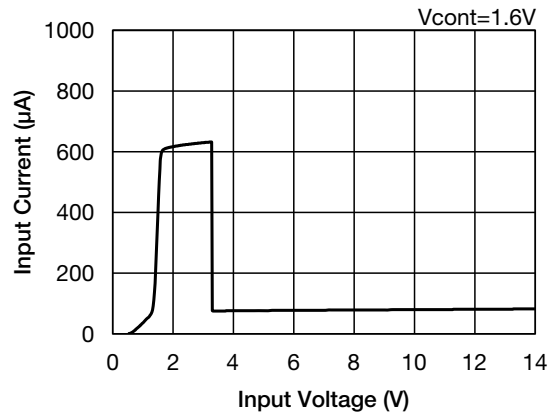

Cont Voltage - Input Current

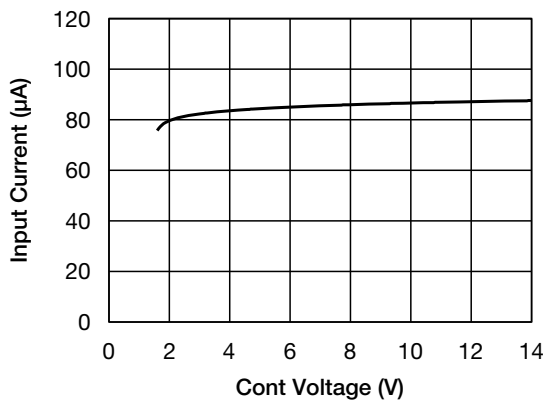

Input Voltage - Output Voltage

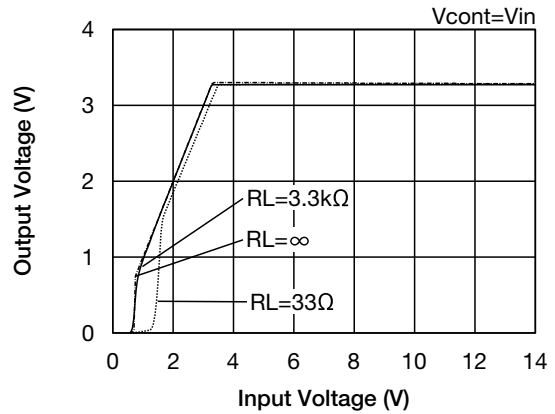

Input Voltage - Output Voltage

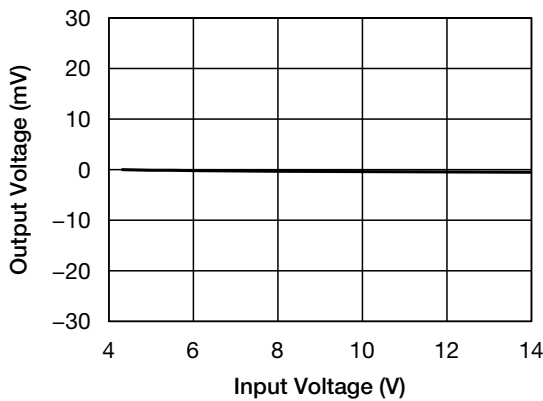

Load Regulation

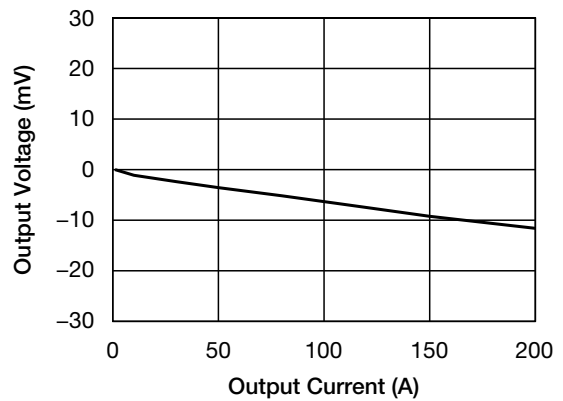

• Any products mentioned in this catalog are subject to any modification in their appearance and others for improvements without prior notification.
• The details listed here are not a guarantee of the individual products at the time of ordering. When using the products, you will be asked to check their specifications.

■ Cont Voltage - Cont pin Current

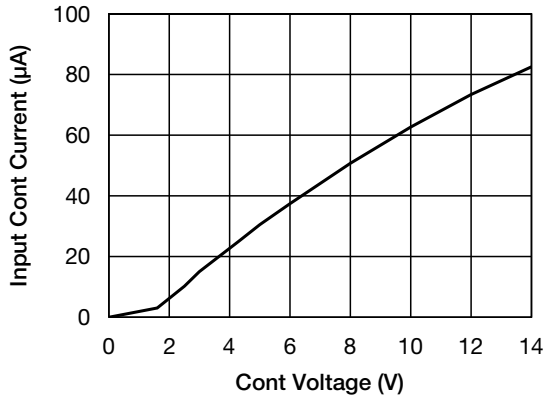

■ Current Limit

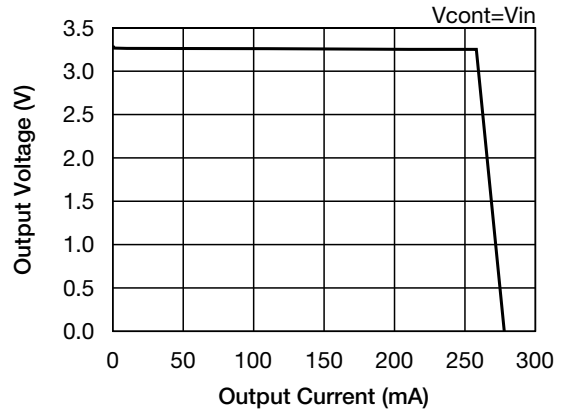

■ Ambient Temperature - Output Voltage

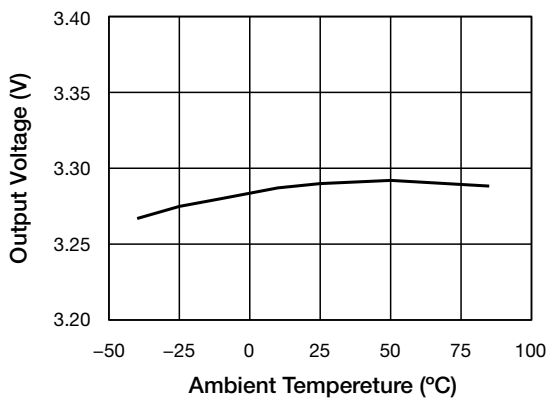

■ Thermal shut down

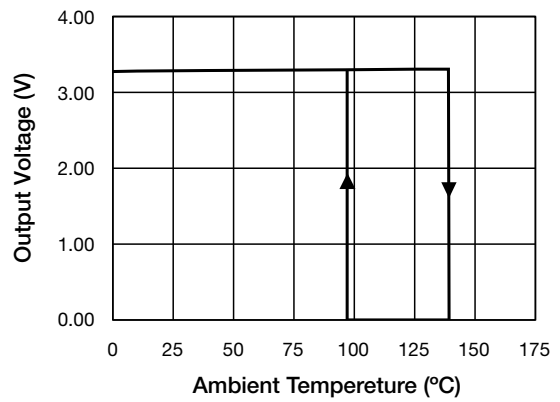

■ Dropout Voltage

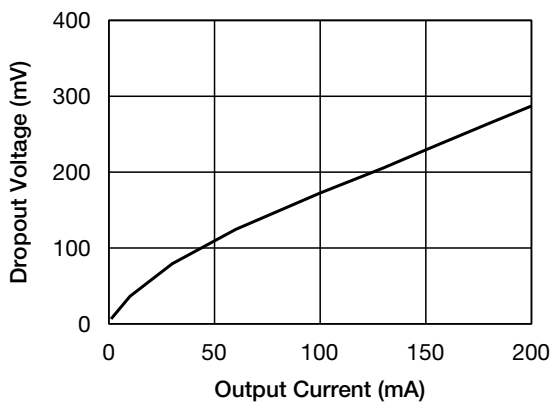

■ Ripple Rejection

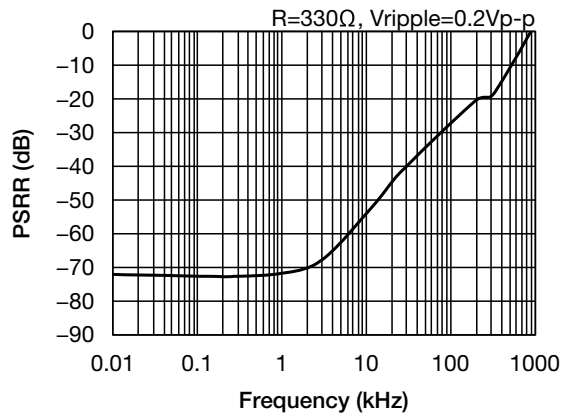

■ ESR stable area

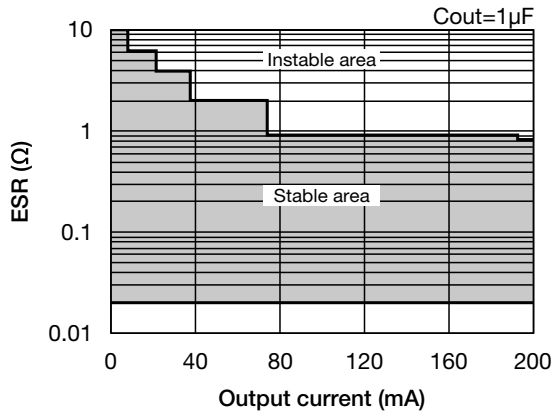

■ ESR stable area

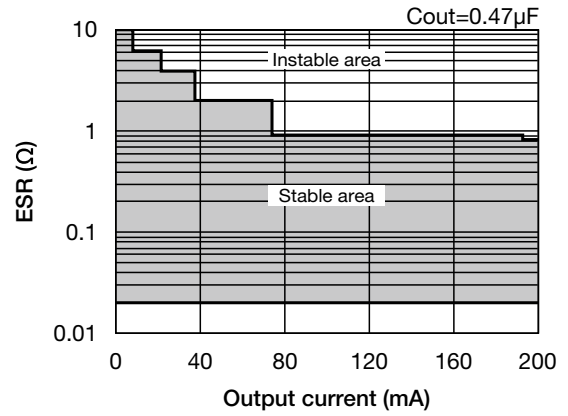

■ Turn-On Transient response

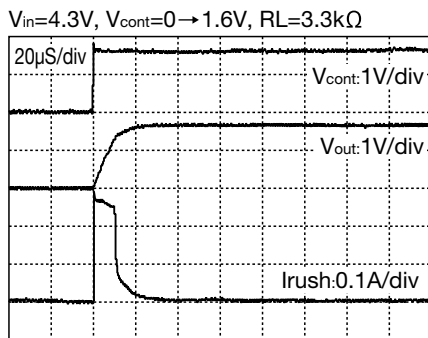

■ Turn-On Transient response

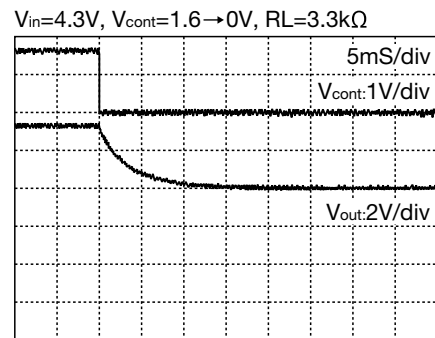

■ Reverse voltage - Reverse current

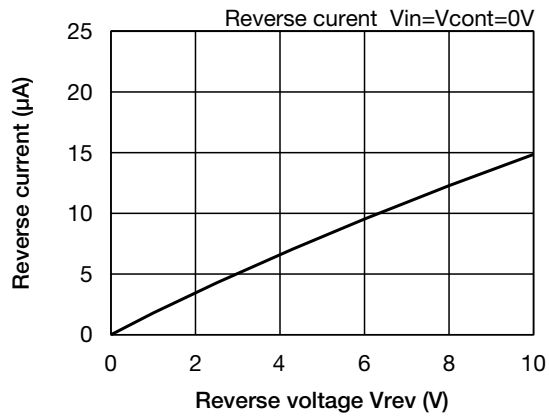

■ Load Transient response

$V_{in}=V_{cout}=4.3V$, $I_o=1mA \leftrightarrow 50mA$, $C_{out}=1\mu F$

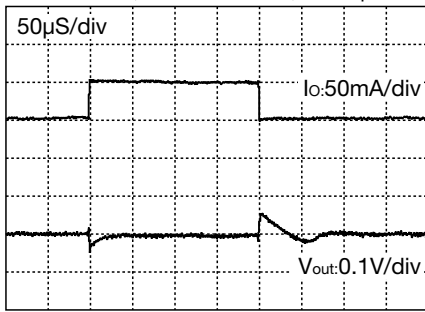

$V_{in}=V_{cout}=4.3V$, $I_o=1mA \leftrightarrow 50mA$, $C_{out}=2.2\mu F$

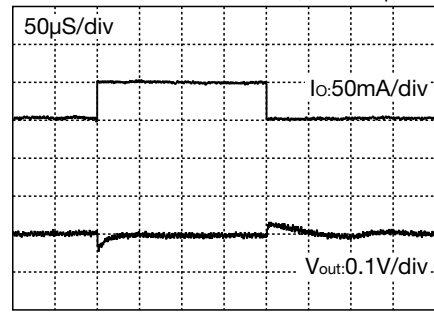

$V_{in}=V_{cout}=4.3V$, $I_o=1mA \leftrightarrow 100mA$, $C_{out}=1\mu F$

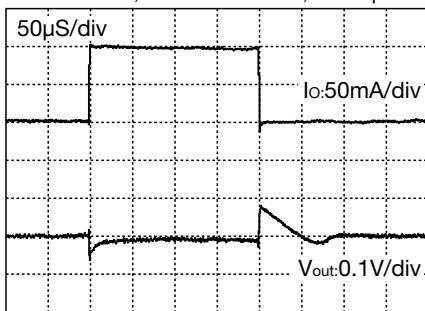

$V_{in}=V_{cout}=4.3V$, $I_o=1mA \leftrightarrow 100mA$, $C_{out}=2.2\mu F$

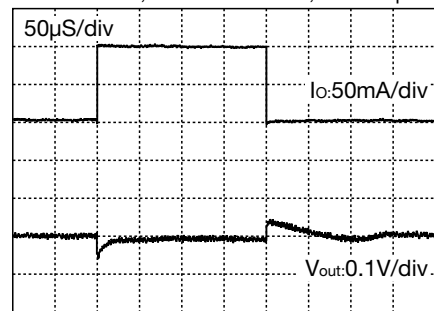

$V_{in}=V_{cout}=4.3V$, $I_o=1mA \leftrightarrow 200mA$, $C_{out}=1\mu F$

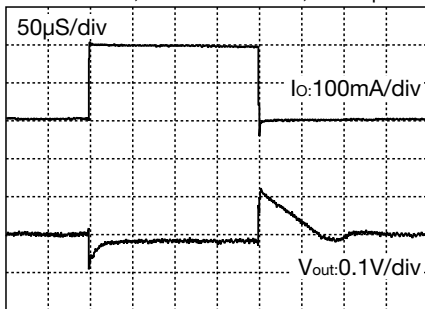

$V_{in}=V_{cout}=4.3V$, $I_o=1mA \leftrightarrow 200mA$, $C_{out}=2.2\mu F$

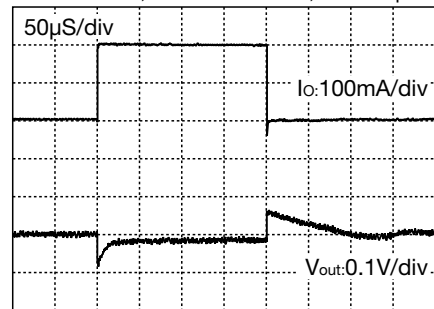

Characteristics (Vo=5.0V) (Except where noted otherwise Vin=Vcont=Vo(typ.)+1V, Iout=1mA, Cin=Co=1μF, Ta=25°C)

Input Voltage - Input Current

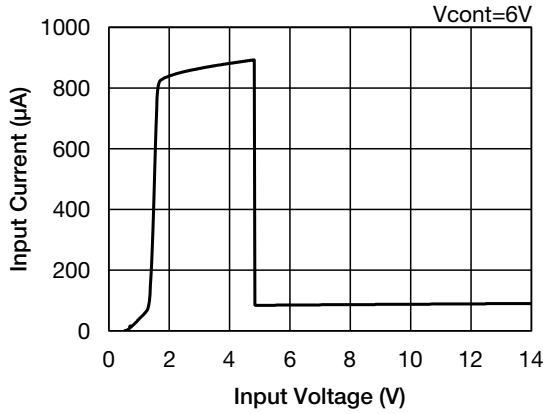

Input Voltage - Input Current

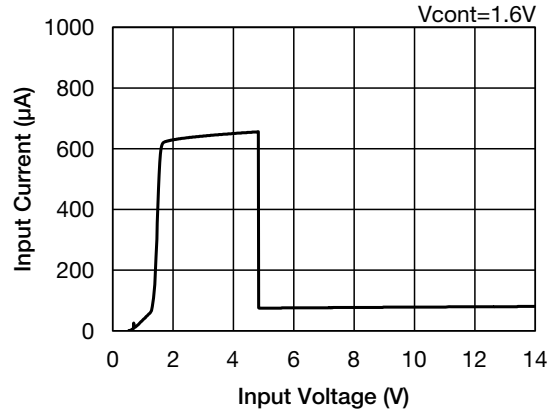

Cont Voltage - Input Current

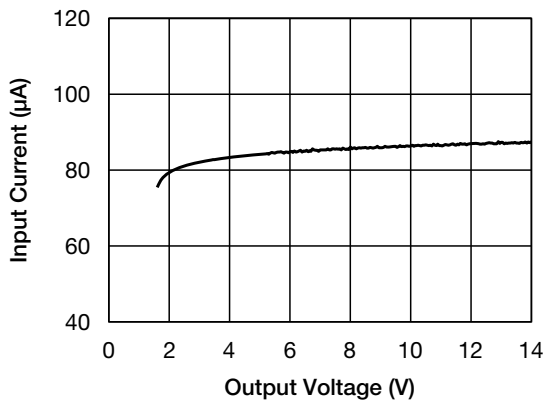

Input Voltage - Output Voltage

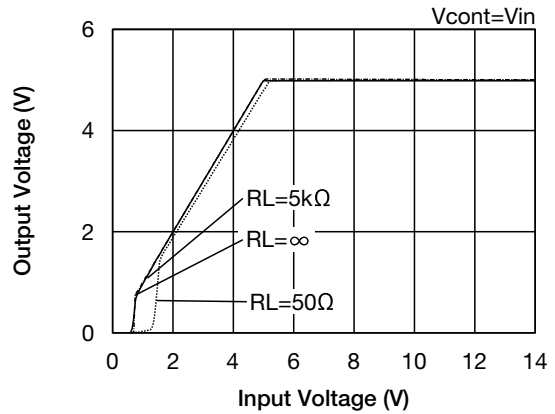

Input Voltage - Output Voltage

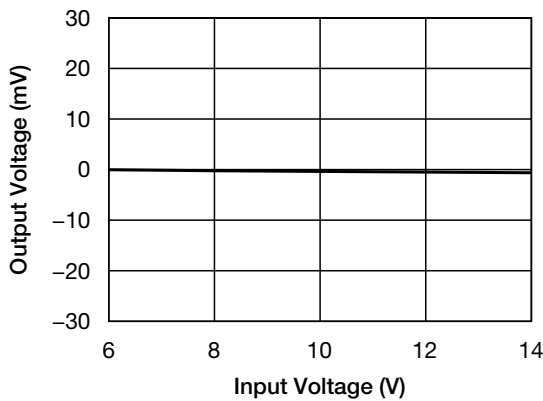

Load Regulation

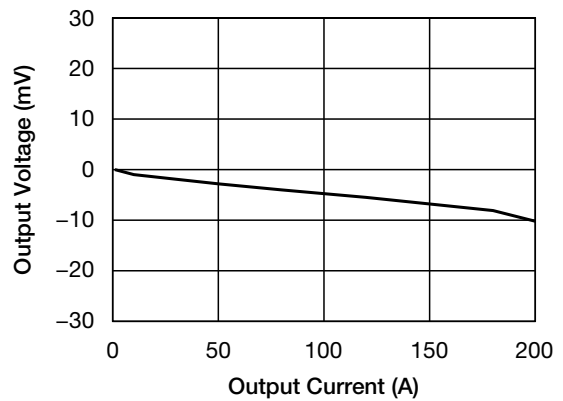

• Any products mentioned in this catalog are subject to any modification in their appearance and others for improvements without prior notification.
 • The details listed here are not a guarantee of the individual products at the time of ordering. When using the products, you will be asked to check their specifications.

■ Cont Voltage - Cont pin Current

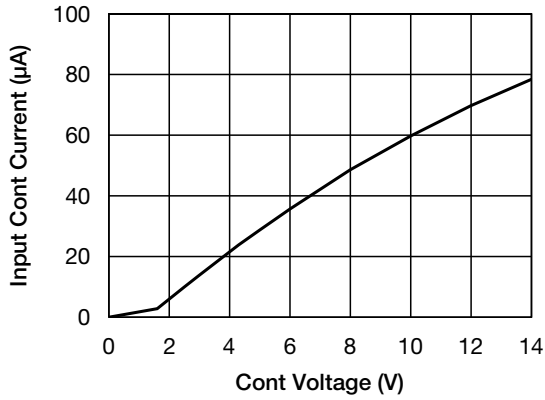

■ Current Limit

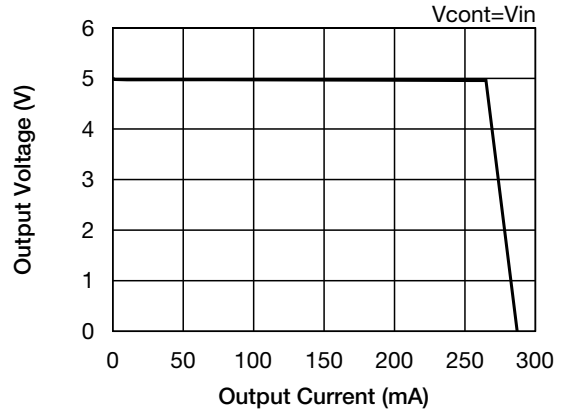

■ Ambient Temperature - Output Voltage

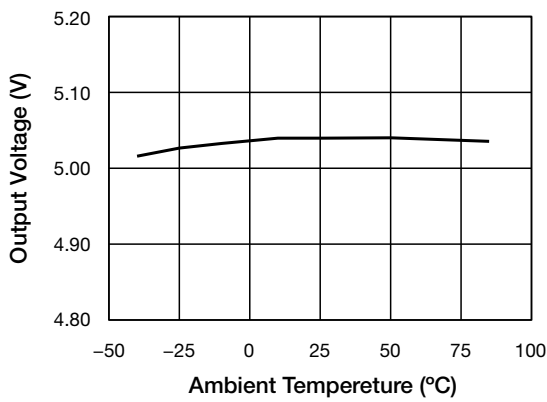

■ Thermal shut down

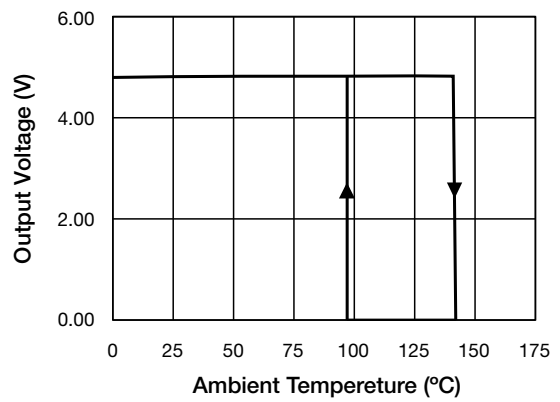

■ Dropout Voltage

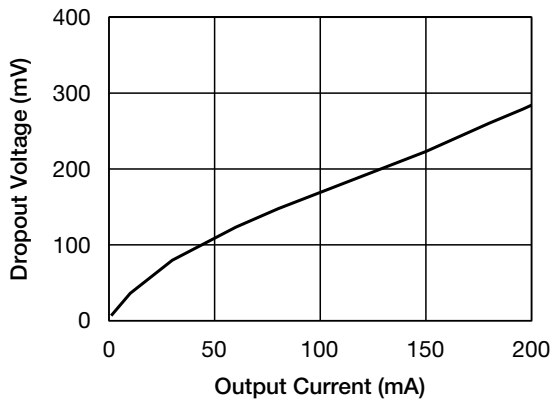

■ Ripple Rejection

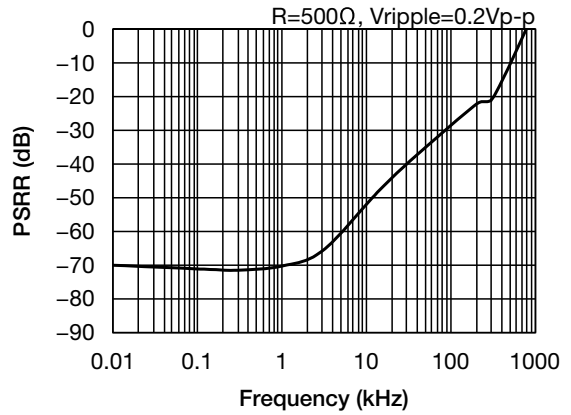

■ ESR stable area

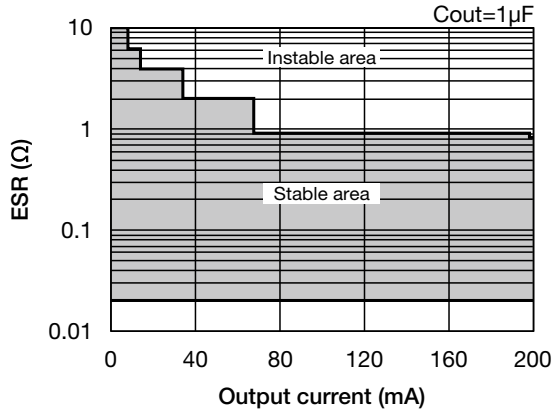

■ ESR stable area

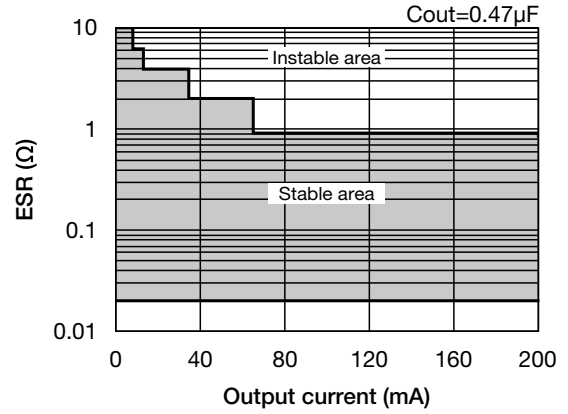

■ Turn-On Transient response

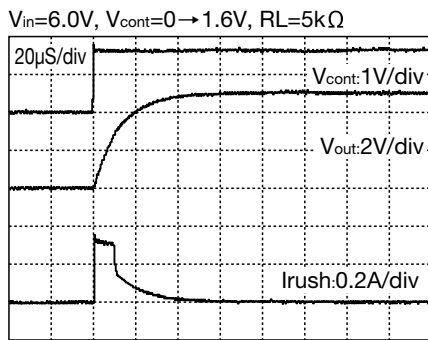

■ Turn-On Transient response

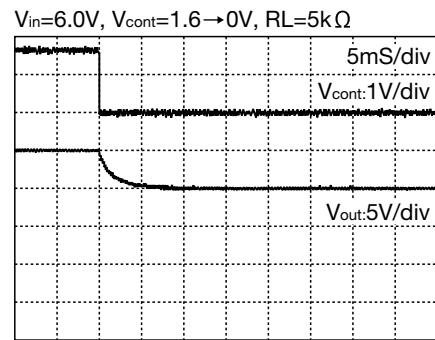

■ Reverse voltage - Reverse current

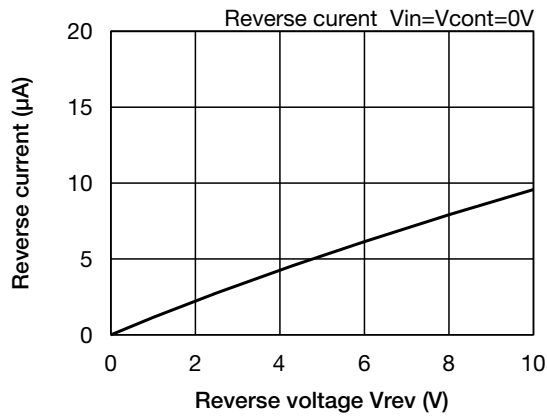

■ Load Transient response

$V_{in}=V_{cout}=6.0V, I_o=1mA \leftrightarrow 50mA, C_{out}=1\mu F$

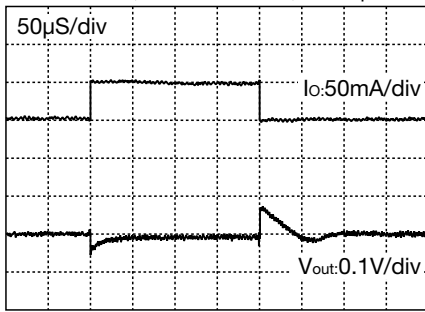

$V_{in}=V_{cout}=6.0V, I_o=1mA \leftrightarrow 50mA, C_{out}=2.2\mu F$

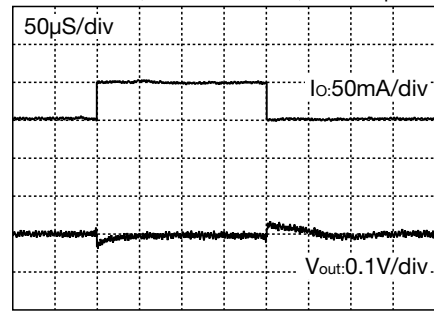

$V_{in}=V_{cout}=6.0V, I_o=1mA \leftrightarrow 100mA, C_{out}=1\mu F$

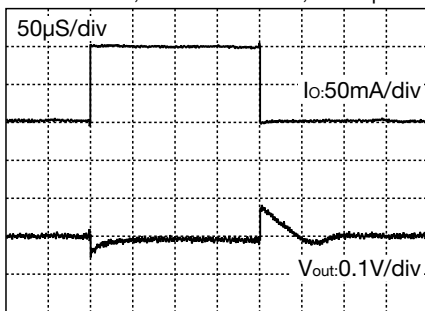

$V_{in}=V_{cout}=6.0V, I_o=1mA \leftrightarrow 100mA, C_{out}=2.2\mu F$

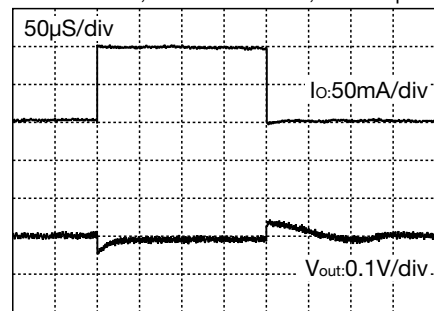

$V_{in}=V_{cout}=6.0V, I_o=1mA \leftrightarrow 200mA, C_{out}=1\mu F$

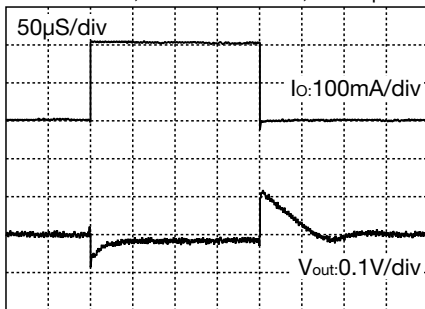

$V_{in}=V_{cout}=6.0V, I_o=1mA \leftrightarrow 200mA, C_{out}=2.2\mu F$

