

200mA LDO

Monolithic IC MM1836 Series

Outline

This IC is a 200mA Low dropout regulator IC with ON/OFF control.
 The IC applies to a standard home equipments, for a maximum operating voltage is 14V.
 Package is a small SOT-25.

Features

- | | |
|------------------------------|-------------------------------------|
| 1. Maximum operating voltage | 14V |
| 2. Output current | 200mA |
| 3. No load input current | 75 μ A typ. |
| 4. Input current(OFF) | 1 μ A max. |
| 5. Output voltage range | 1.5~5.0V |
| 6. Output voltage accuracy | \pm 2% |
| 7. Dropout voltage | 300mV typ. (I _o =200mA) |
| 8. Line regulation | 0.1%/V max. |
| 9. Load regulation | 60mV max. (I _o =1~200mA) |
| 10. Ripple rejection | 70dB typ. (f=1kHz) |
| 11. Output Capacitor | 1 μ F |
| 12. ON/OFF control | |
| 13. Thermal shutdown | |

Package

SOT-25A

Applications

1. TV
2. BD recorder
3. Printer
4. Game

Block Diagram

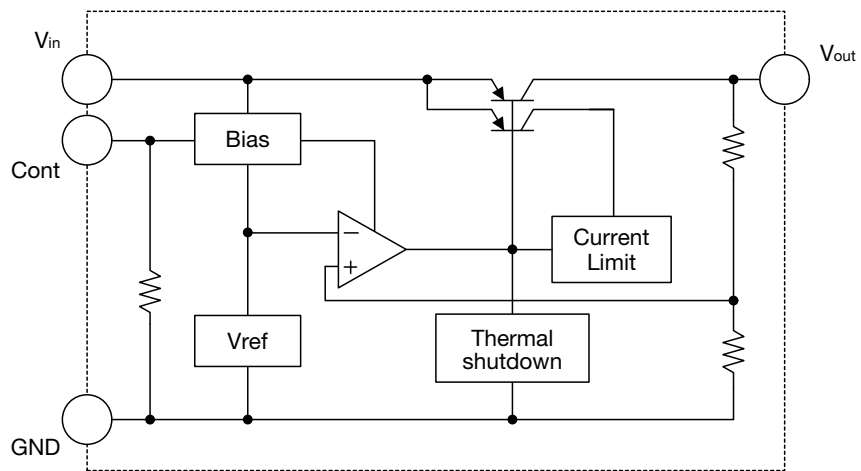

Pin Assignment

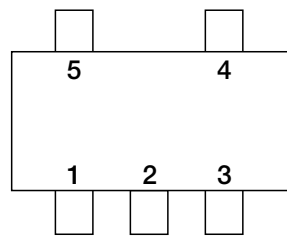

1	Cont
2	GND
3	NC
4	Vout
5	Vin

SOT-25A
(TOP VIEW)

Pin Description

Pin No.	Pin name	Functions	Internal equivalent circuit diagram						
1	Cont	ON/OFF Control pin <table border="1"> <tr> <td>Cont</td> <td>Vout</td> </tr> <tr> <td>H</td> <td>ON</td> </tr> <tr> <td>L</td> <td>OFF</td> </tr> </table> Cont pin must be connected with Vin pin, if it is not used.	Cont	Vout	H	ON	L	OFF	
Cont	Vout								
H	ON								
L	OFF								
2	GND	Ground							
3	NC	No connection							
4	Vout	Output pin The capacitor must be connected with output pin more than 1 μ F.							
5	Vin	Input pin The capacitor is required to connect with input pin more than 1 μ F.							

Absolute Maximum Ratings (Except where noted otherwise Ta=25°C)

Item	Symbol	Ratings	Units
Storage Temperature	Tstg	-55~+150	°C
Operating Temperature	Topr	-40~+85	°C
Supply Voltage	Vin	-0.3~+15	V
Cont PIN Voltage	Vcont	-0.3~+15	
Output Current	Iout	350	mA
Power Dissipation	Pd	350(Note1)	mW

Note1 : With the PC Board of glass epoxy.
(60 × 40 × 1.6mm)

Recommended Operating Conditions (Except where noted otherwise Ta=25°C)

Item	Symbol	Ratings	Units
Output Current	Iout	0~200	mA
Operating Voltage	Vop	1.8~14	V

• Any products mentioned in this catalog are subject to any modification in their appearance and others for improvements without prior notification.
• The details listed here are not a guarantee of the individual products at the time of ordering. When using the products, you will be asked to check their specifications.

Electrical Characteristics 1 (Except where noted otherwise $V_{in}=V_o(\text{typ.})+1V$, $I_o=1mA$, $V_{cont}=1.6V$, $T_a=25^{\circ}C$)

Item	Symbol	Measurement conditions	Min.	Typ.	Max.	Units
No-Load Input Current	I _{cc}	I _o =0mA V _{cont} =VDD		75	120	μA
Input Current(OFF)	I _{ccoff}	V _{Cont} =0V		0	1	μA
Output Voltage (Note3)	V _{OUT}	I _o =1mA	×0.98		×1.02	V
Dropout Voltage (Note4)	V _{io}	V _{in} =V _o -0.2V, I _o =200mA		0.3	0.5	V
Line Regulation	ΔV1	V _{in} =V _o +1~14V, I _o =1mA			0.1	%/V
Load Regulation	ΔV2	I _o =1~200mA		15	60	mV
Vout Temperature Coefficient (Note2)	ΔV _{out} /ΔT	T _a =-40~+85°C		±100		ppm/°C
Ripple Rejection (Note2)	RR	f=1kHz V _{ripple} =1V _{p-p} , I _o =10mA		70		dB
Cont Pin Input Current	I _{cont}	V _{cont} =1.6V		3	12	μA
Cont Pin High Threshold Level	V _{contH}		1.6			V
Cont Pin Low Threshold Level	V _{contL}				0.3	V

Note2 : The parameter is guaranteed by design.

Note3 : Please refer to another page.

Note4 : The parameter is not guaranteed in the model less than V_{OUT}=2V.

Electrical Characteristics 2 (Except where noted otherwise $V_{in}=V_o(\text{typ.})+1V$, $I_o=1mA$, $V_{cont}=1.6V$, $T_a=25^\circ C$)

Model No.	Measurement Conditions	Output Voltage (V)		
		Min.	Typ.	Max.
MM1836A15	$I_o=1mA$	1.470	1.5	1.530
MM1836A16		1.568	1.6	1.632
MM1836A17		1.666	1.7	1.734
MM1836A18		1.764	1.8	1.836
MM1836A19		1.862	1.9	1.938
MM1836A20		1.960	2.0	2.040
MM1836A21		2.058	2.1	2.142
MM1836A22		2.156	2.2	2.244
MM1836A23		2.254	2.3	2.346
MM1836A24		2.352	2.4	2.448
MM1836A25		2.450	2.5	2.550
MM1836A26		2.548	2.6	2.652
MM1836A27		2.646	2.7	2.754
MM1836A28		2.744	2.8	2.856
MM1836A29		2.842	2.9	2.958
MM1836A30		2.940	3.0	3.060
MM1836A31		3.038	3.1	3.162
MM1836A32		3.136	3.2	3.264
MM1836A33		3.234	3.3	3.366
MM1836A34		3.332	3.4	3.468
MM1836A35		3.430	3.5	3.570
MM1836A36		3.528	3.6	3.672
MM1836A37		3.626	3.7	3.774
MM1836A38		3.724	3.8	3.876
MM1836A39		3.822	3.9	3.978
MM1836A40		3.920	4.0	4.080
MM1836A41		4.018	4.1	4.182
MM1836A42		4.116	4.2	4.284
MM1836A43		4.214	4.3	4.386
MM1836A44		4.312	4.4	4.488
MM1836A45		4.410	4.5	4.590
MM1836A46		4.508	4.6	4.692
MM1836A47		4.606	4.7	4.794
MM1836A48		4.704	4.8	4.896
MM1836A49		4.802	4.9	4.998
MM1836A50		4.900	5.0	5.100

• Any products mentioned in this catalog are subject to any modification in their appearance and others for improvements without prior notification.
 • The details listed here are not a guarantee of the individual products at the time of ordering. When using the products, you will be asked to check their specifications.

Measuring Circuit

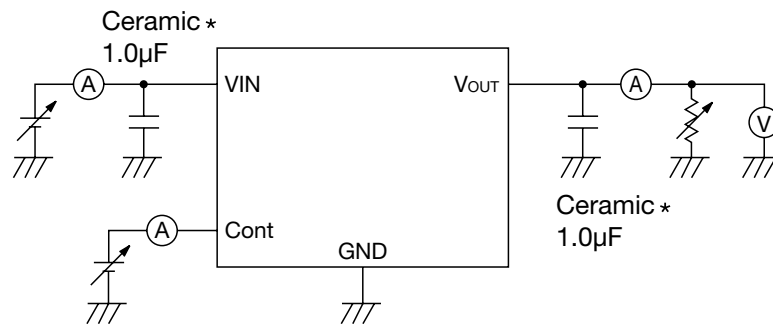

Application Circuit

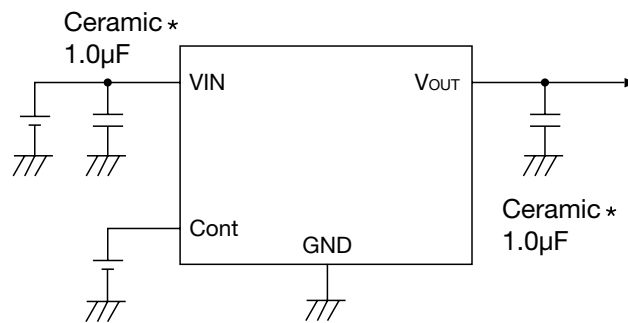

* Temperature Characteristics : B

(Reference example of external parts)

- Output capacitor Ceramic capacitor 1.0µF
- Input capacitor Ceramic capacitor 1.0µF

· In the event a problem which may affect industrial property or any other rights of us or a third party is encountered during the use of information described in these circuit, we shall not be liable for any such problem, nor grant a license therefore.

· Note

1. There is a possibility with deterioration and destruction of IC when using it exceeding the absolute maximum rating. The absolute maximum rating , Never exceed it. The functional operation is not assured.
2. There is a possibility that it becomes impossible to maintain this performance and reliability IC original when using it exceeding recommended operation voltage.
Please use it in recommended operation voltage.
3. Due to restrictions on the package power dissipation, the output current value may not be satisfied. Attention should be paid to the power dissipation of the package when the output current is large or the voltage between Iinput and Output is high.
4. The output capacitor is required between output and GND to prevent oscillation.
5. The ESR of capacitor must be defined in ESR stability area. It is possible to use a ceramic capacitor without ESR resistance for output. The ceramic capacitor must be used more than 1.0µF and B temperature characteristics.
6. The wire of VDD and GND is required to print full ground plane for noise and stability.
7. The input capacitor must be connected a distance of less than 1cm from input pin.

8. It is able to an unstable operation when you use the capacitor with intense capacitance change
The capacitor has the dependency at the power-supply voltage and the temperature.
The capacity value changes by the environment used. Please evaluate IC in the set.
9. In case the output voltage is above the input voltage, the overcurrent flow by internal parasitic diode from output to input. In such application, the external bypass diode must be connected between output and input pin.
10. There is a possibility of becoming an unstable operation. when using it with Dropout voltage no margin.
Please evaluate it enough when there is no margin in Dropout voltage.
11. The overcurrent protection circuit of the vertical type is built into this IC.
12. There is a possibility that IC generates heat when the output terminal is short-circuited. However, the thermal shutdown circuit operates, and it will do operation that protects IC.
The thermal shutdown circuit is designed only to shut the IC off to prevent thermal runaway.
Do not continue to use the IC in an environment where the operation of this circuit is assumed.
The characteristic changes depending on the substrate condition. Please evaluate IC in the set.
13. The hysteresis circuit is not built into the thermal shutdown circuit. It returns automatically in temperature returned after it shuts down by self-generation of heat. After it returns, it shuts down again by self-generation of heat. It is necessary to change the environment used (IC consumption, temperature) if it operates in upper cycle.

About Power Dissipation

The Power dissipation change if board to mount IC change because radiative heat fix at board. It is reference data below, Evaluate IC in the set.

1. PC Board of glass epoxy
Board size 60mm×40mm t=1.6mm Copper foil area 60%
Power dissipation 350mW Ta=25°C
2. JEDEC51-7 standard
Board size 114.3mm×76.2mm t=1.6mm Copper foil area 80%
Power dissipation 700mW Ta=25°C (It is reference value measured by JEDEC51-7 standard.)

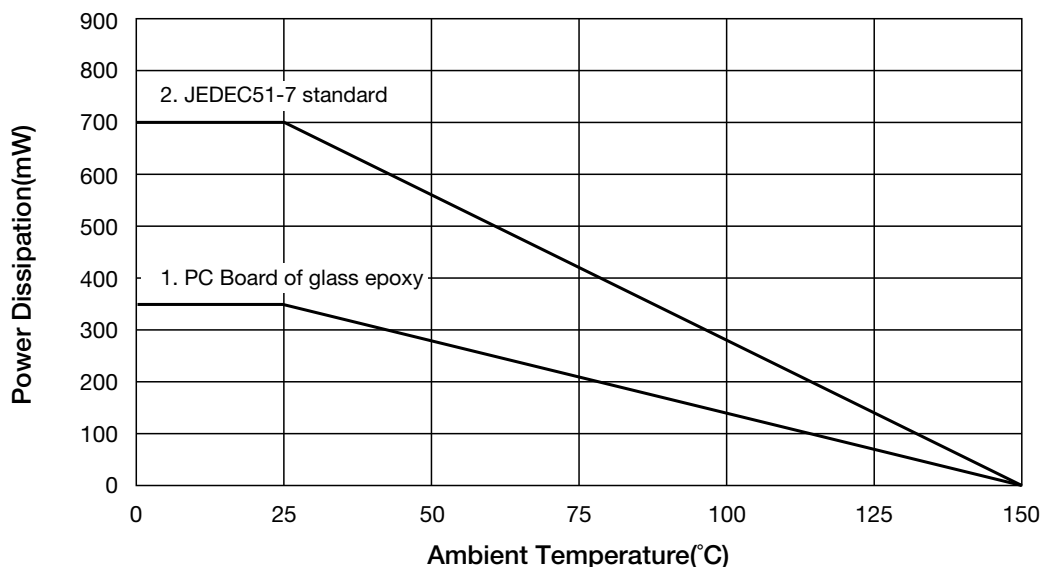

It is recommended to layout the VIA for heat radiation in the GND pattern of reverse (of IC) when there is the GND pattern in the inner layer (in using multiplayer substrate).

By increasing these copper foil pattern area of PCB, Power dissipation improves.

Characteristics (Vo=1.5V) (Except where noted otherwise Vin=Vo(typ.)+1V, Iout=1mA, Vcont=Vo+1V, Cin=Co=1μF, Ta=25°C)

Input voltage - Input current

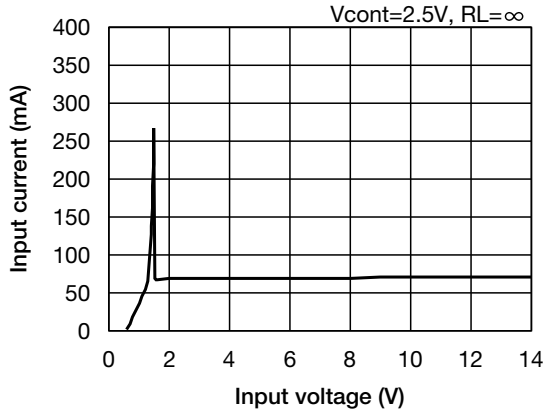

Input voltage - Input current

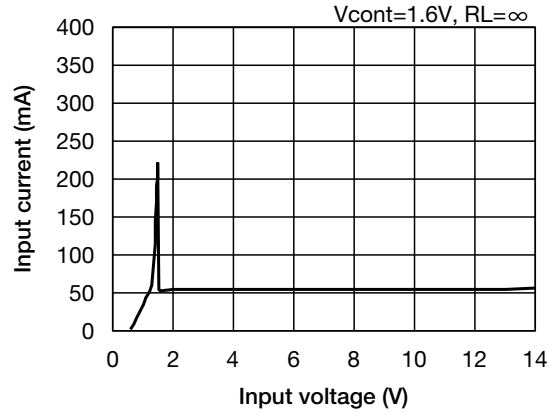

Cont pin voltage - Input current

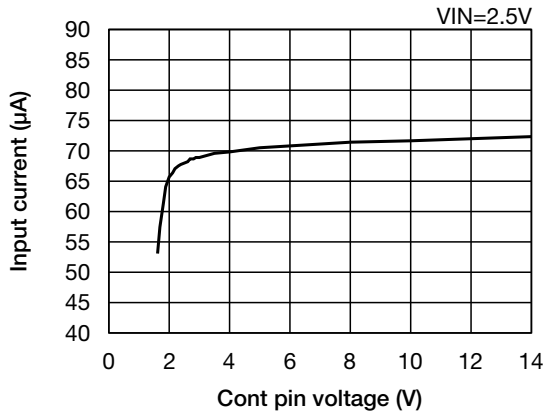

Input voltage - Output voltage

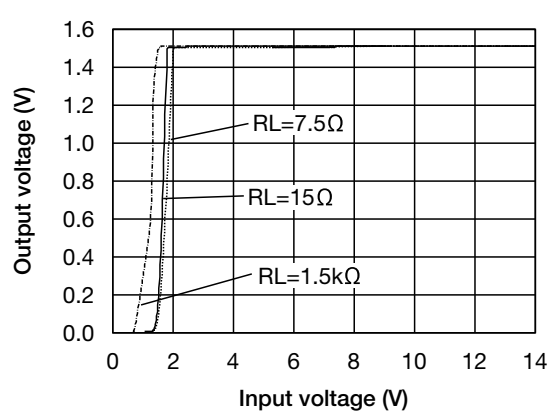

Line regulation

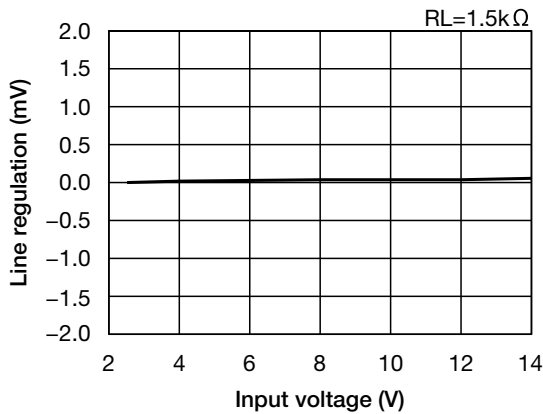

Load regulation

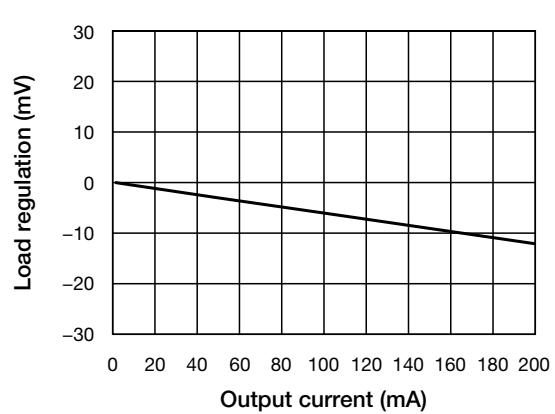

• Any products mentioned in this catalog are subject to any modification in their appearance and others for improvements without prior notification.
 • The details listed here are not a guarantee of the individual products at the time of ordering. When using the products, you will be asked to check their specifications.

■ Cont pin voltage - Cont pin current

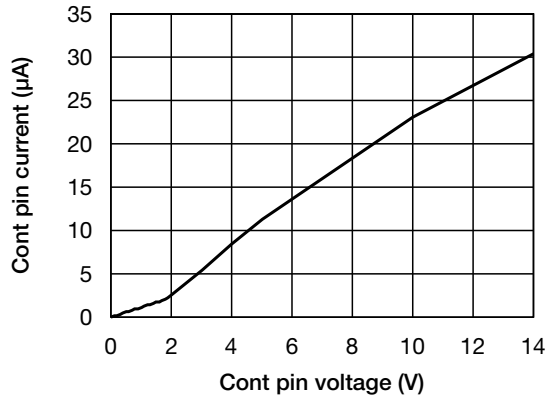

■ Current Limit

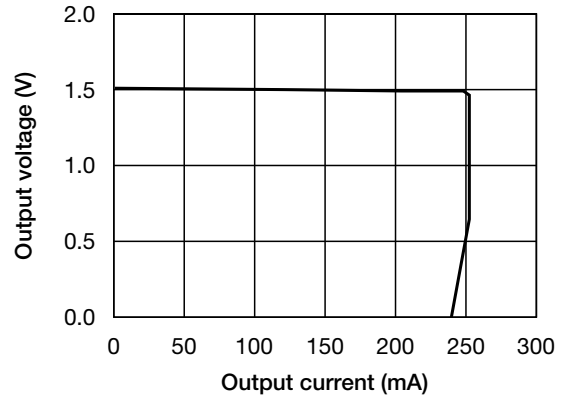

■ Ambient Temperature - Output voltage

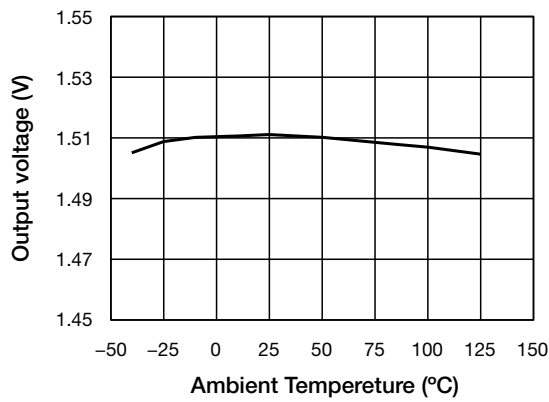

■ Thermal Shut Down

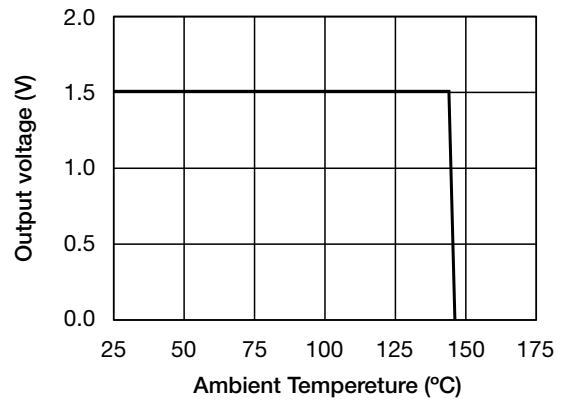

■ Ripple Rejection

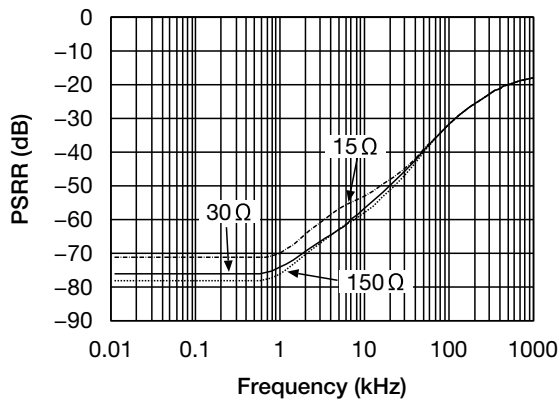

■ ESR stable area

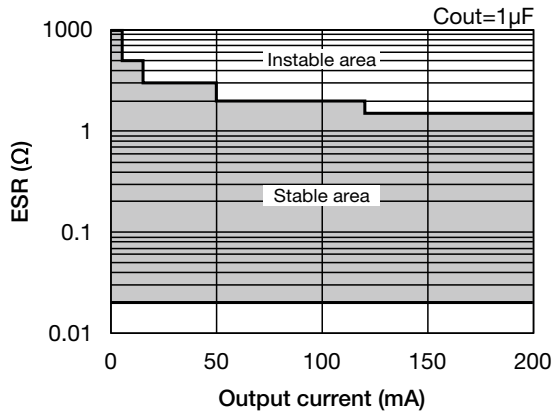

■ ESR stable area

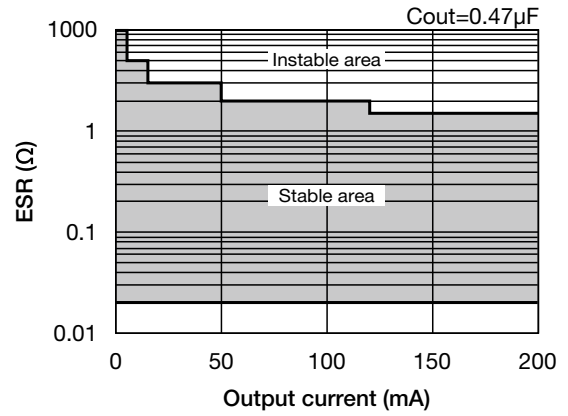

■ Turn-On Transient response

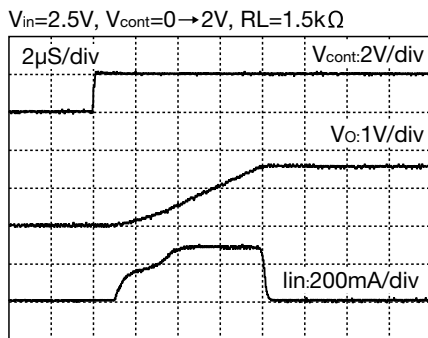

■ Turn-Off Transient response

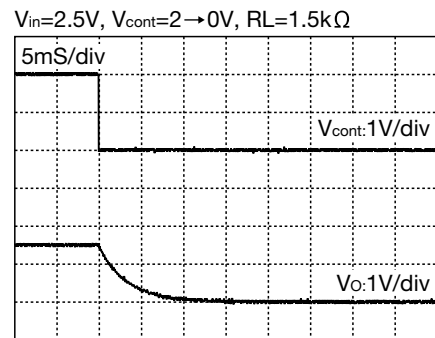

■ Load Transient response

$V_{in}=V_{out}=2.5V, I_o=1mA \leftrightarrow 50mA, C_{out}=1\mu F$

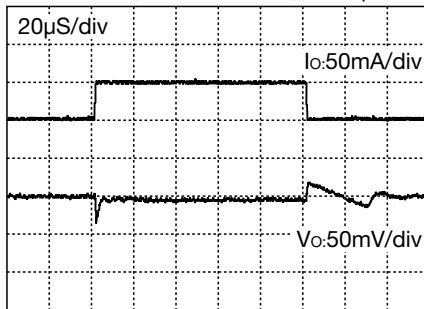

$V_{in}=V_{out}=2.5V, I_o=1mA \leftrightarrow 50mA, C_{out}=2.2\mu F$

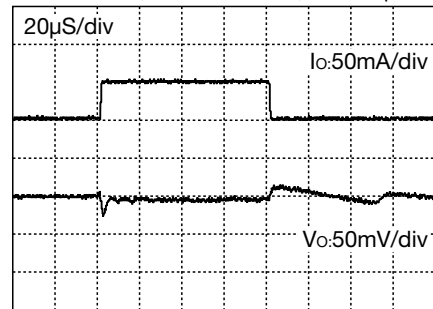

$V_{in}=V_{out}=2.5V, I_o=1mA \leftrightarrow 100mA, C_{out}=1\mu F$

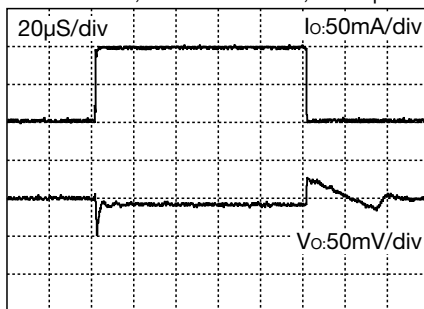

$V_{in}=V_{out}=2.5V, I_o=1mA \leftrightarrow 100mA, C_{out}=2.2\mu F$

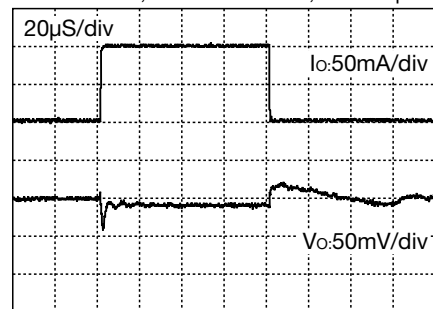

$V_{in}=V_{out}=2.5V, I_o=1mA \leftrightarrow 200mA, C_{out}=1\mu F$

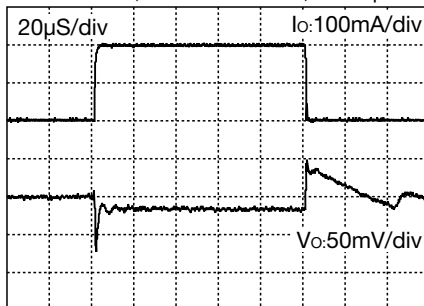

$V_{in}=V_{out}=2.5V, I_o=1mA \leftrightarrow 200mA, C_{out}=2.2\mu F$

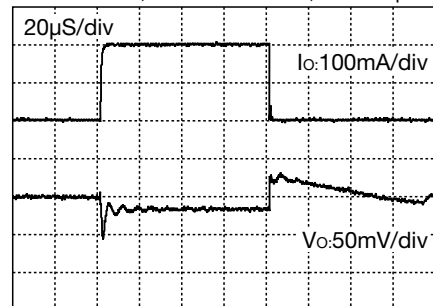

Characteristics (Vo=3.3V) (Except where noted otherwise Vin=Vo(typ.)+1V, Iout=1mA, Vcont=Vo+1V, Cin=Co=1μF, Ta=25°C)

Input voltage - Input current

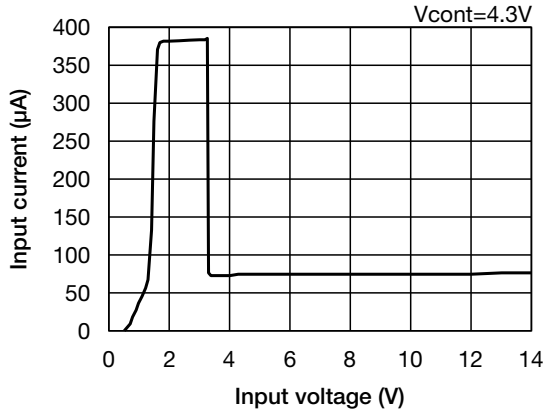

Input voltage - Input current

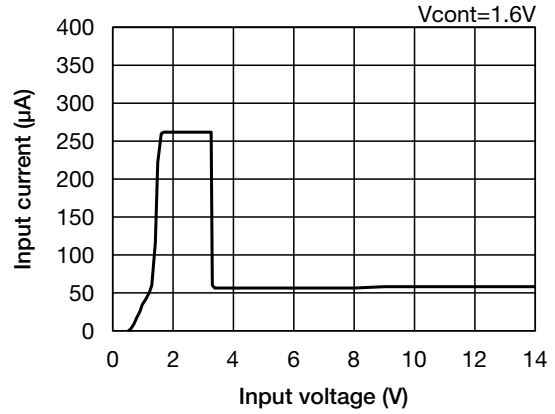

Cont pin voltage - Input current

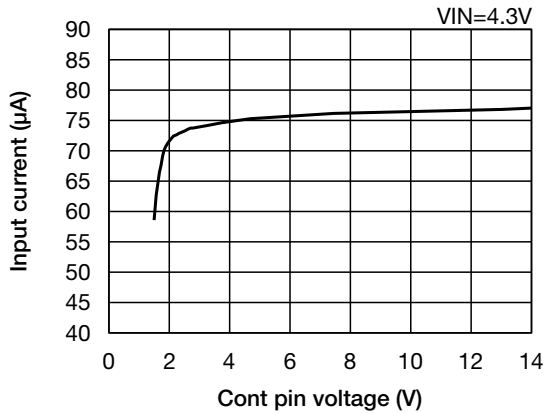

Input voltage - Output voltage

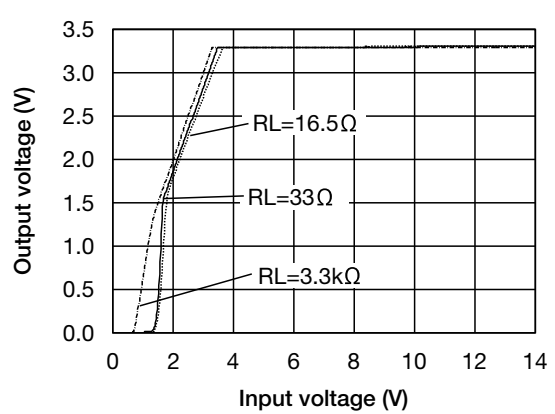

Line regulation

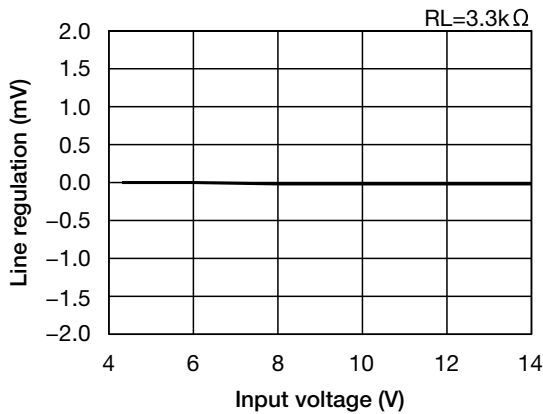

Load regulation

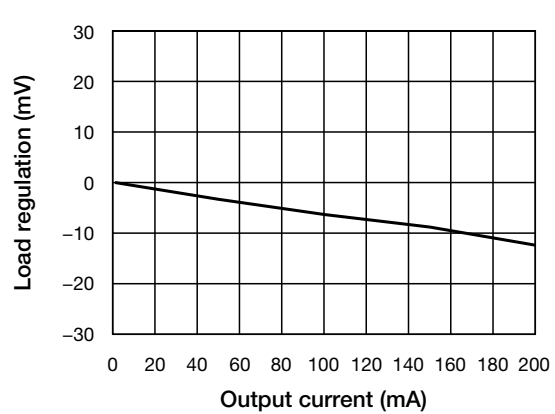

• Any products mentioned in this catalog are subject to any modification in their appearance and others for improvements without prior notification.
• The details listed here are not a guarantee of the individual products at the time of ordering. When using the products, you will be asked to check their specifications.

■ Cont pin voltage - Cont pin current

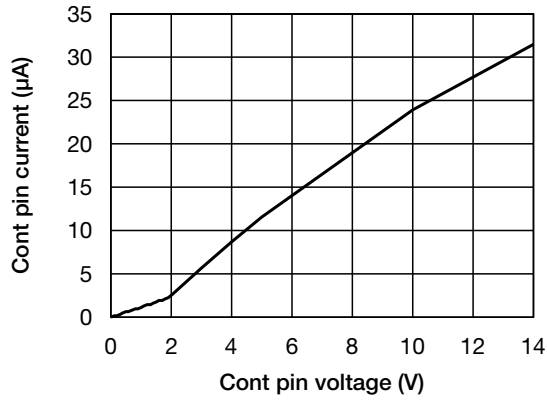

■ Output current - Dropout voltage

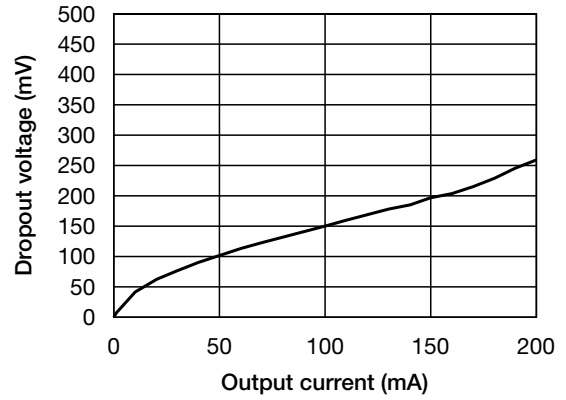

■ Current Limit

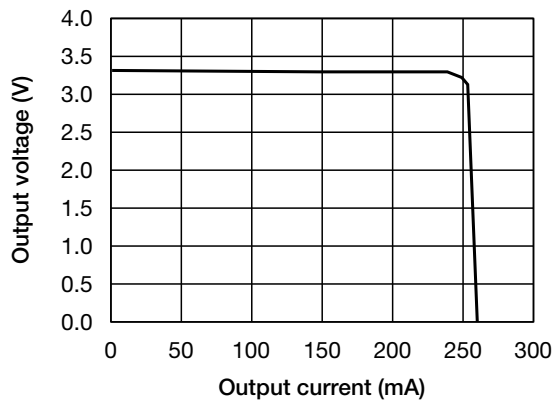

■ Ambient Temperature - Output voltage

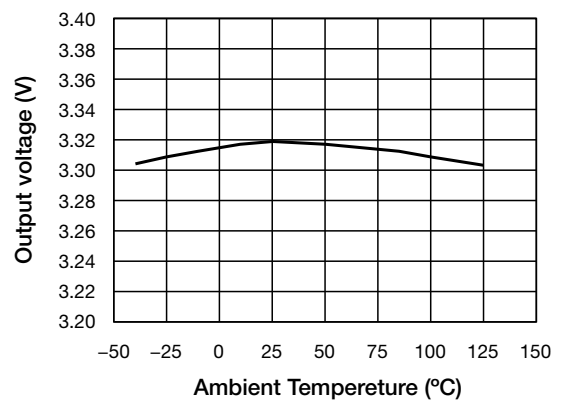

■ Thermal Shut Down

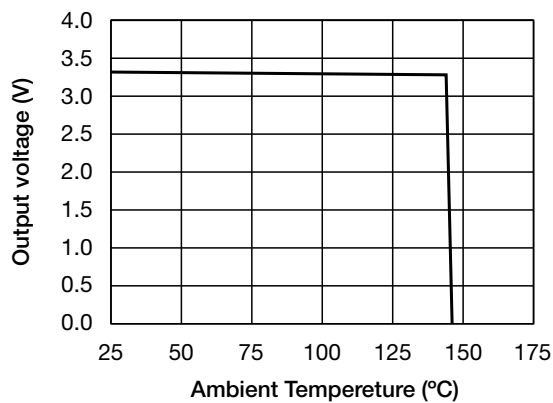

■ Ripple Rejection

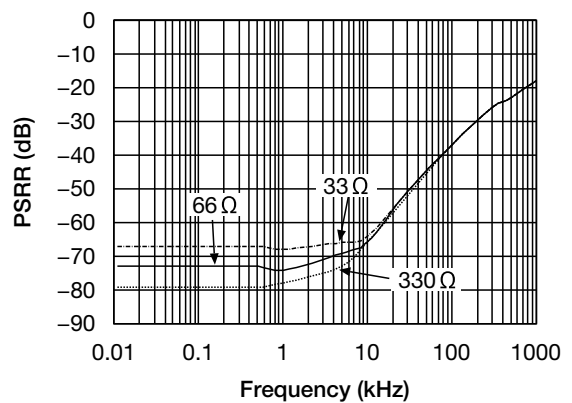

■ ESR stable area

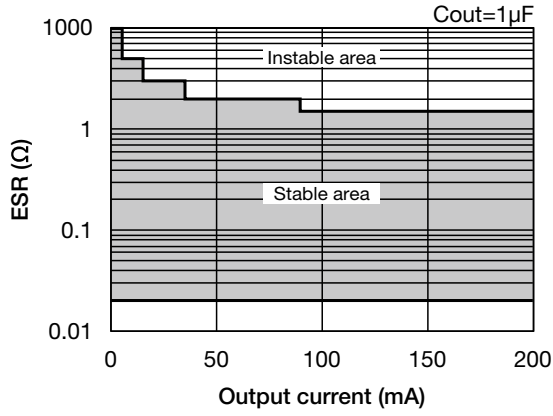

■ ESR stable area

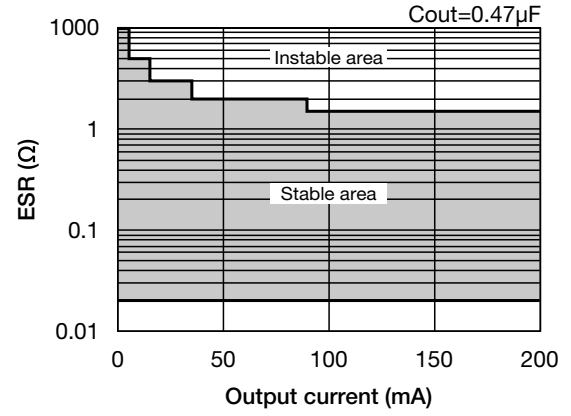

■ Turn-On Transient response

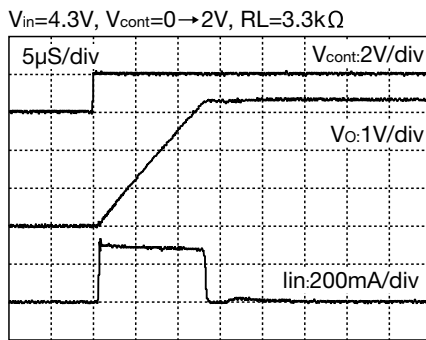

■ Turn-Off Transient response

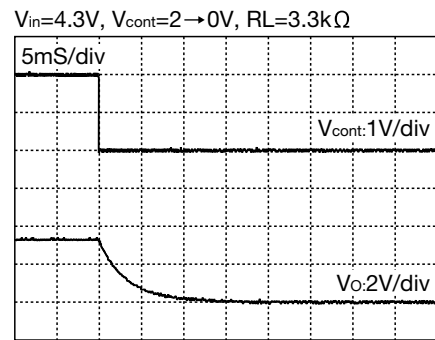

■ Load Transient response

$V_{in}=V_{out}=4.3V$, $I_o=1mA \leftrightarrow 50mA$, $C_{out}=1\mu F$

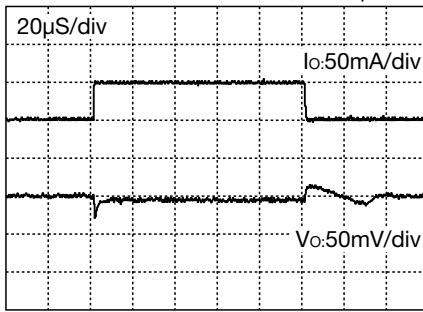

$V_{in}=V_{out}=4.3V$, $I_o=1mA \leftrightarrow 50mA$, $C_{out}=2.2\mu F$

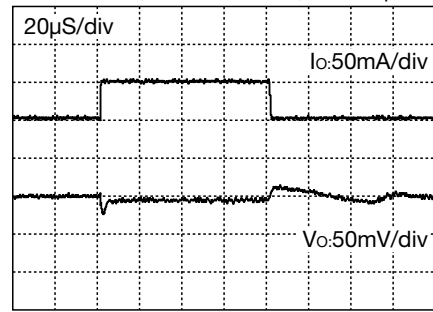

$V_{in}=V_{out}=4.3V$, $I_o=1mA \leftrightarrow 100mA$, $C_{out}=1\mu F$

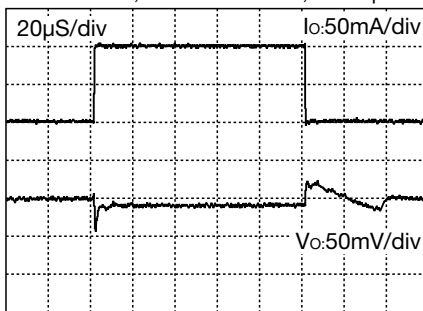

$V_{in}=V_{out}=4.3V$, $I_o=1mA \leftrightarrow 100mA$, $C_{out}=2.2\mu F$

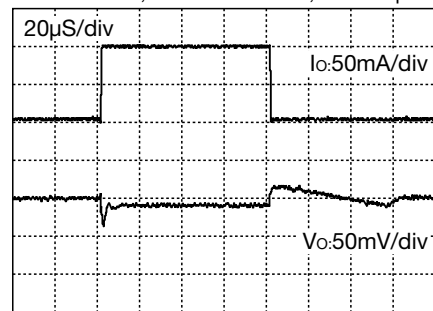

$V_{in}=V_{out}=4.3V$, $I_o=1mA \leftrightarrow 200mA$, $C_{out}=1\mu F$

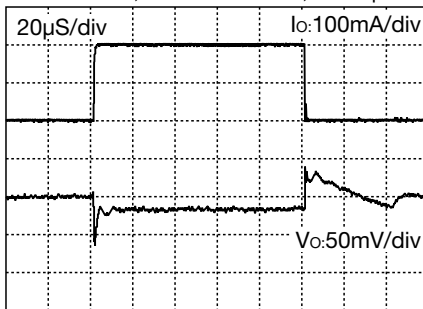

$V_{in}=V_{out}=4.3V$, $I_o=1mA \leftrightarrow 200mA$, $C_{out}=2.2\mu F$

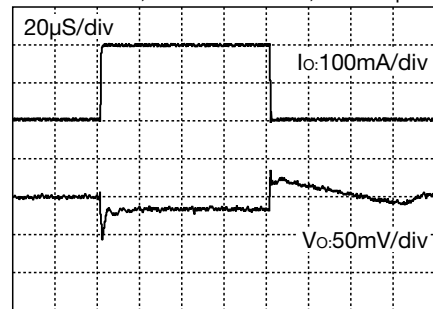

Characteristics (Vo=5.0 V) (Except where noted otherwise Vin=Vo(typ.)+1V, Iout=1mA, Vcont=Vo+1V, Cin=Co=1μF, Ta=25°C)

■ Input voltage - Input current

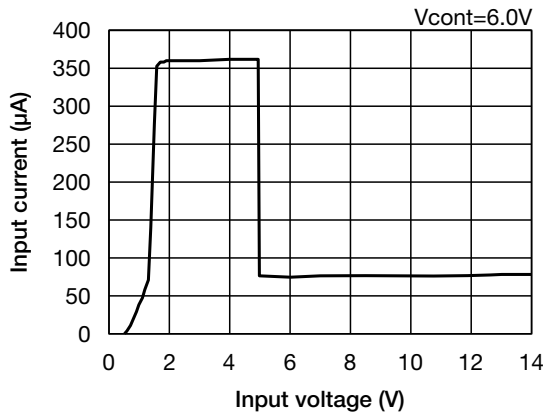

■ Input voltage - Input current

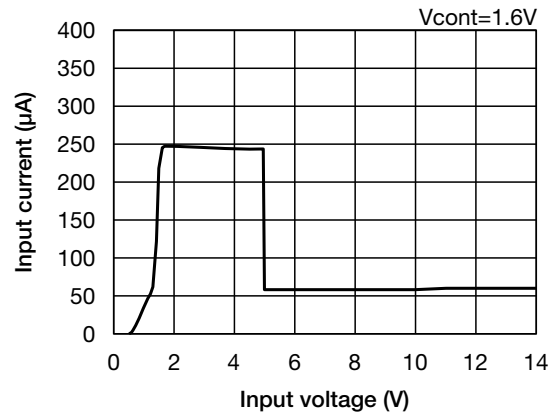

■ Cont pin voltage - Input current

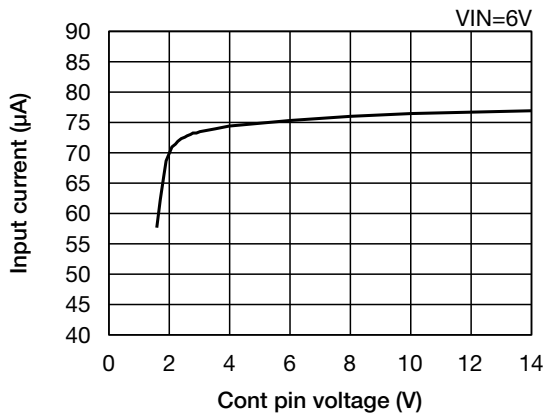

■ Input voltage - Output voltage

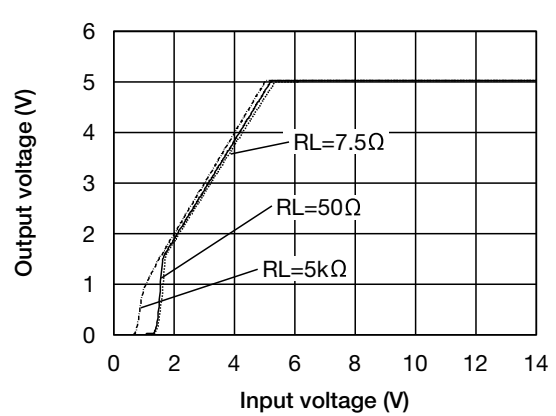

■ Line regulation

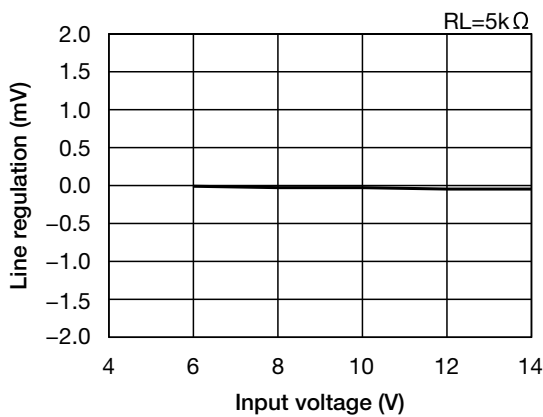

■ Load regulation

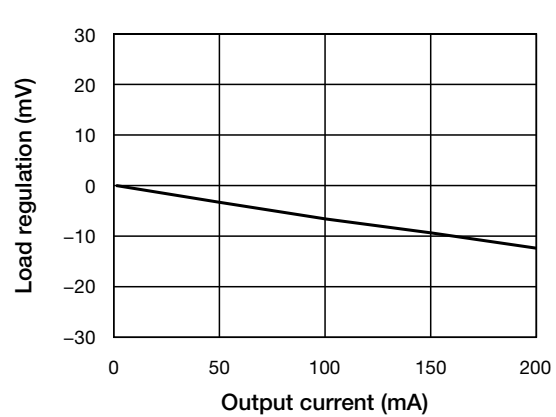

■ Cont pin voltage - Cont pin current

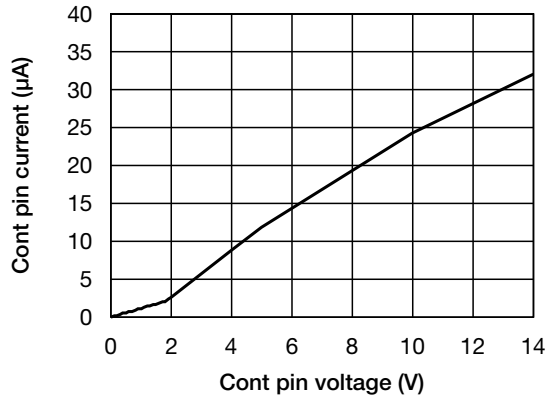

■ Output current - Dropout voltage

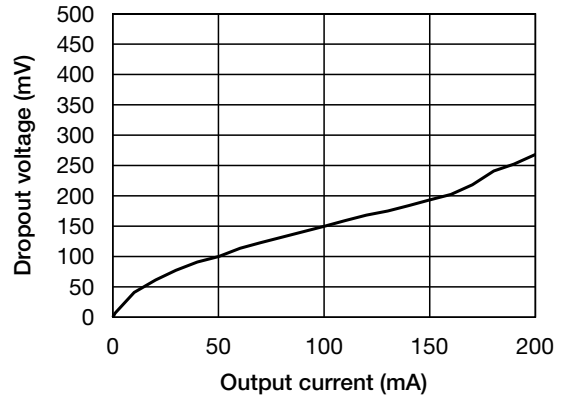

■ Current Limit

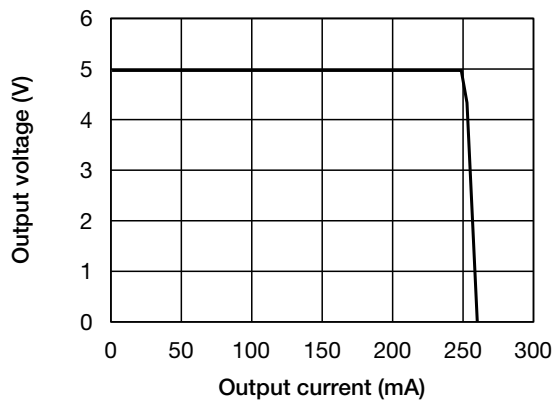

■ Ambient Temperature - Output voltage

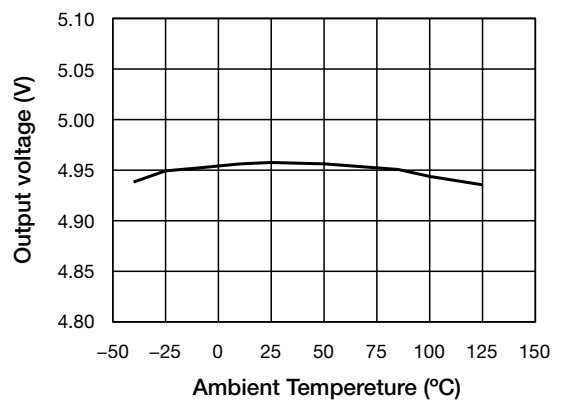

■ Thermal Shut Down

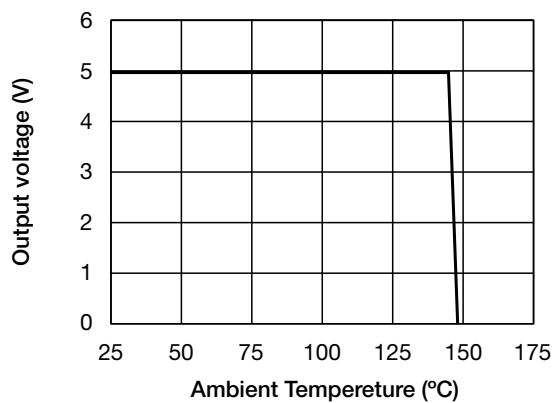

■ Ripple Rejection

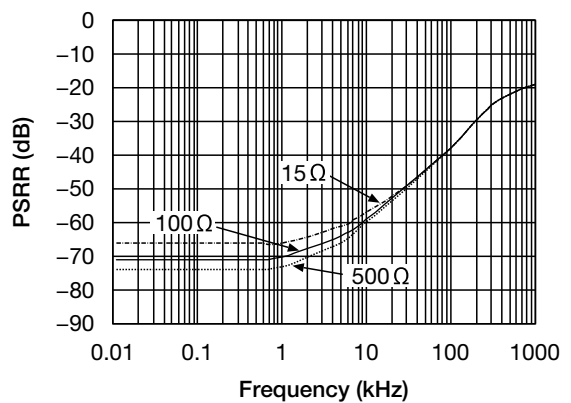

■ ESR stable area

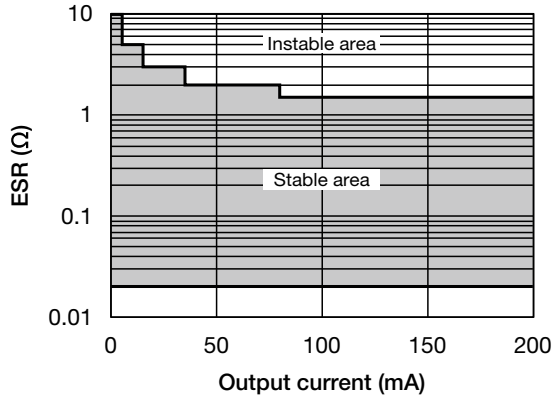

■ ESR stable area

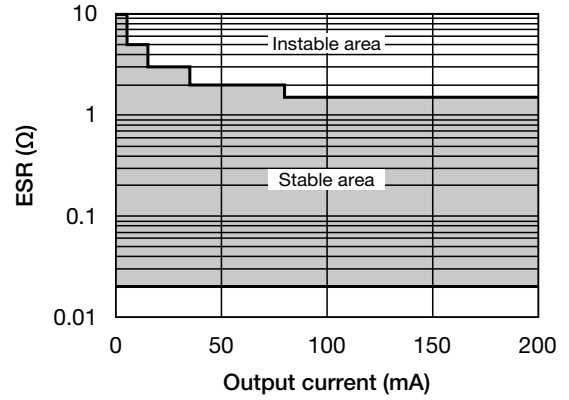

■ Turn-On Transient response

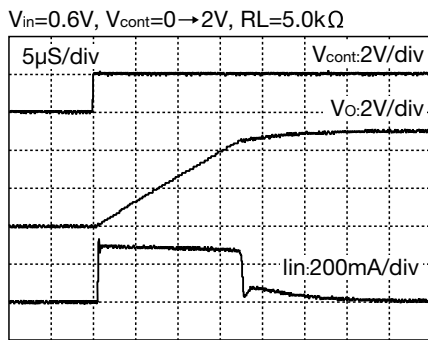

■ Turn-Off Transient response

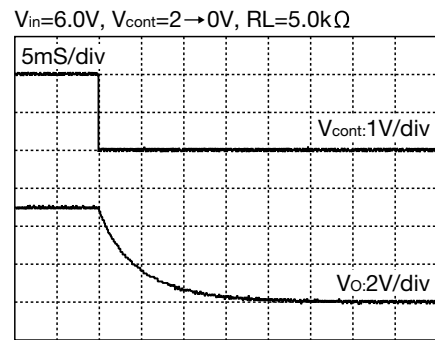

■ Load Transient response

$V_{in}=V_{out}=6.0V$, $I_o=1mA \leftrightarrow 50mA$, $C_{out}=1\mu F$

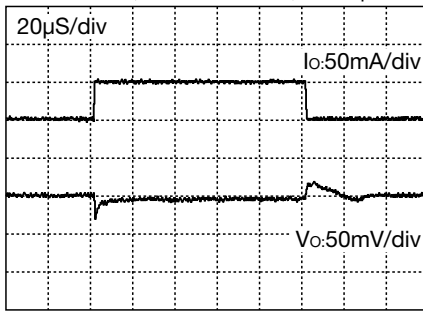

$V_{in}=V_{out}=6.0V$, $I_o=1mA \leftrightarrow 50mA$, $C_{out}=2.2\mu F$

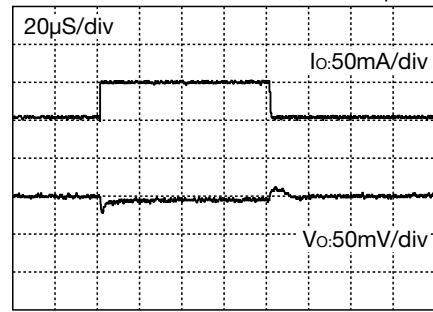

$V_{in}=V_{out}=6.0V$, $I_o=1mA \leftrightarrow 100mA$, $C_{out}=1\mu F$

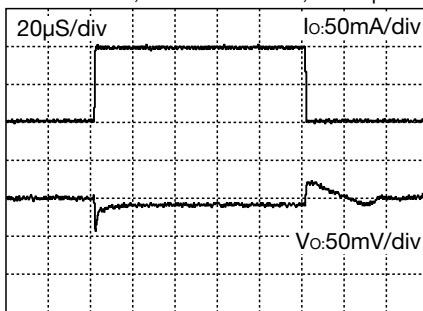

$V_{in}=V_{out}=6.0V$, $I_o=1mA \leftrightarrow 100mA$, $C_{out}=2.2\mu F$

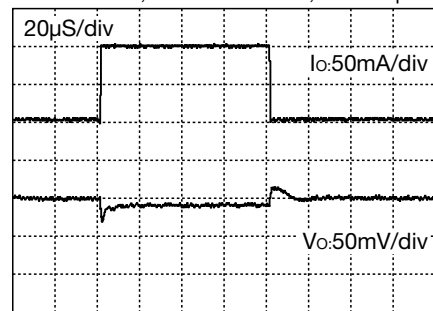

$V_{in}=V_{out}=6.0V$, $I_o=1mA \leftrightarrow 200mA$, $C_{out}=1\mu F$

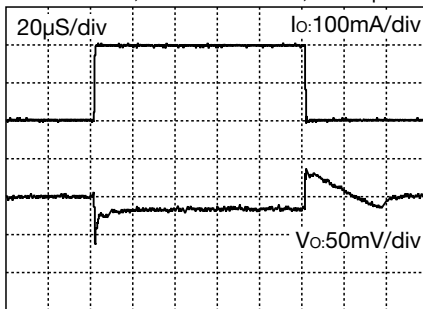

$V_{in}=V_{out}=6.0V$, $I_o=1mA \leftrightarrow 200mA$, $C_{out}=2.2\mu F$

