

200mA LDO

Monolithic IC MM3411 Series

Outline

This IC is a 200mA Low dropout regulator IC with Rush current protection circuit.
 No load input current is 25 μ A typ., and it reduce drop voltage for high speed response.
 Rush current protection circuit can control rush current.
 The package is ultra-small size of 1010, and it applies to mobile equipment.

Features

1. Maximum operating voltage	6.5V
2. Output current	200mA
3. No load input current	25 μ A typ.
4. Input current (OFF)	1 μ A max.
5. Output voltage range	0.8~5.0V
6. Output voltage accuracy	\pm 1%
7. Dropout voltage	0.40V typ. (I _{OUT} =200mA)
8. Line regulation	\pm 0.1%/V max.
9. Load regulation	60mV max. (I _{OUT} =1~200mA)
10. Ripple rejection	70dB typ. (f=1kHz)
11. Output Capacitor	0.47 μ F
12. ON/OFF control	

Package

PLP-4A
 SC-82ABB
 SOT-25A

Applications

1. Mobile phone, Smart phone
2. Digital camera
3. Game equipment
4. Tablet

Model Name

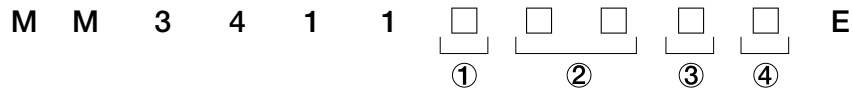

①		②	
Function Type		Voltage Output RANK	
A	CE=H-Active, with Discharge Function	08	①=A V_o (typ.) =0.80V
Z			①=Z V_o (typ.) =0.85V
		ˆ	①=A V_o (typ.) =0.10V step ①=Z V_o (typ.) =0.05V step
		50	①=A V_o (typ.) =5.00V

③		④	
Package		Packing Specifications	
U	SC-82ABB	R	R HOUSING
N	SOT-25A		
R	PLP-4A (1010 size)		

• Any products mentioned in this catalog are subject to any modification in their appearance and others for improvements without prior notification.
 • The details listed here are not a guarantee of the individual products at the time of ordering. When using the products, you will be asked to check their specifications.

Block Diagram

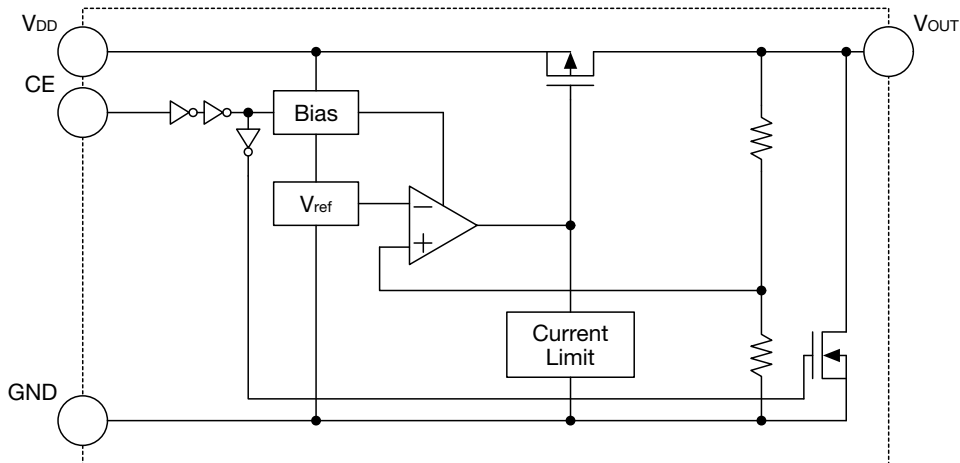

Pin Assignment

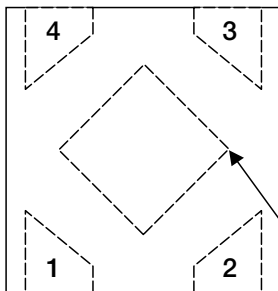

PLP-4A
(TOP VIEW)

1	V _{OUT}
2	GND
3	CE
4	V _{DD}

Heat Spreader Bottom
Note1

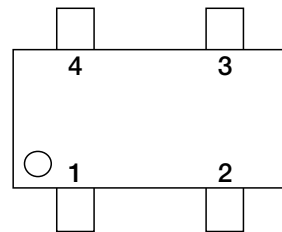

SC-82ABB
(TOP VIEW)

1	CE
2	GND
3	V _{OUT}
4	V _{DD}

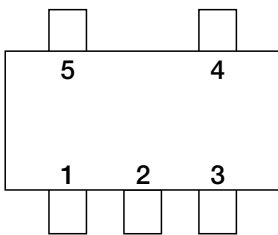

SOT-25A
(TOP VIEW)

1	V _{DD}
2	GND
3	CE
4	NC
5	V _{OUT}

Note1 : Heat Spreader Bottom with GND.

• Any products mentioned in this catalog are subject to any modification in their appearance and others for improvements without prior notification.
• The details listed here are not a guarantee of the individual products at the time of ordering. When using the products, you will be asked to check their specifications.

Pin Description

PLP-4A

Pin No.	Pin name	Functions						
1	V _{OUT}	Output pin						
2	GND	GND pin						
3	CE	ON/OFF-Control pin						
		<table border="1"> <tr> <th>CE</th> <th>OUTPUT</th> </tr> <tr> <td>L</td> <td>OFF</td> </tr> <tr> <td>H</td> <td>ON</td> </tr> </table>	CE	OUTPUT	L	OFF	H	ON
		CE	OUTPUT					
		L	OFF					
H	ON							
Connect CE pin with V _{DD} pin, when it is not used. And it Can not be used at OPEN, because it don't have pulldown.								
4	V _{DD}	Voltage-supply pin						

SC-82ABB

Pin No.	Pin name	Functions						
1	CE	ON/OFF-Control pin						
		<table border="1"> <tr> <th>CE</th> <th>OUTPUT</th> </tr> <tr> <td>L</td> <td>OFF</td> </tr> <tr> <td>H</td> <td>ON</td> </tr> </table>	CE	OUTPUT	L	OFF	H	ON
		CE	OUTPUT					
		L	OFF					
H	ON							
Connect CE pin with V _{DD} pin, when it is not used. And it Can not be used at OPEN, because it don't have pulldown.								
2	GND	GND pin						
3	V _{OUT}	Output pin						
4	V _{DD}	Voltage-Supply pin						

SOT-25A

Pin No.	Pin name	Functions						
1	V _{DD}	Voltage-supply pin						
2	GND	GND pin						
3	CE	ON/OFF-Control pin						
		<table border="1"> <tr> <th>CE</th> <th>OUTPUT</th> </tr> <tr> <td>L</td> <td>OFF</td> </tr> <tr> <td>H</td> <td>ON</td> </tr> </table>	CE	OUTPUT	L	OFF	H	ON
		CE	OUTPUT					
		L	OFF					
H	ON							
Connect CE pin with V _{DD} pin, when it is not used. And it Can not be used at OPEN, because it don't have pulldown.								
4	NC	No connection						
5	V _{OUT}	Output pin						

Absolute Maximum Ratings (Except where noted otherwise Ta=25°C)

Item	Symbol	Ratings	Units
Storage Temperature	T _{stg}	-55~+150	°C
Junction Temperature	T _{JMAX}	150	°C
Supply Voltage	V _{DD}	-0.3~+7.0	V
CE input Voltage	V _{CE}	-0.3~+7.0	V
Output Voltage	V _{OUT}	-0.3~+7.0	V
Output Current	I _{omax}	400	mA
Power Dissipation 1	Pd1	850(Note2) (PLP-4A)	mW
		330(Note2) (SC-82ABB)	
		350(Note3) (SOT-25A)	
Power Dissipation 2	Pd2	1300(Note4) (PLP-4A)	mW
		650(Note4) (SC-82ABB)	
		700(Note4) (SOT-25A)	

Note2 : With PC Board of glass epoxy 100 × 100 × 1.6mm

Note3 : With PC Board of glass epoxy 60 × 40 × 1.6mm

Note4 : JEDEC51-7 standard 114.3 × 76.2 × 1.6mm

• Any products mentioned in this catalog are subject to any modification in their appearance and others for improvements without prior notification.
 • The details listed here are not a guarantee of the individual products at the time of ordering. When using the products, you will be asked to check their specifications.

Recommended Operating Conditions (Except where noted otherwise Ta=25°C)

Item	Symbol	Ratings	Units
Operating Ambient Temperature	Topr	-40~+85	°C
Operating Voltage	Vop	1.8~6.5	V
Output Current	Iop	0~200	mA

Electrical Characteristics 1 (Except where noted otherwise VDD=VOUT(TYP.)+1V, VCE=VDD, Ta=25°C)

Item	Symbol	Measurement conditions	Min.	Typ.	Max.	Units
Input Current(OFF)	IDDOFF	VCE=0V		0.01	0.1	μA
No-Load Input Current	IDD	IOUT=0mA		25	40	μA
Output Voltage	VOUT	IOUT=10mA (VOUT≥2.00V)	×0.99		×1.01	V
		IOUT=10mA (VOUT<2.00V)	-0.02		+0.02	V
Line Regulation	VLINE	VOUT (TYP.)+0.5V≤VDD≤6.5V VOUT≥1.10V, IOUT=10mA		0.01	0.10	%/V
		VOUT (TYP.)+1.0V≤VDD≤6.5V VOUT≤1.05V, IOUT=10mA				
Load Regulation 1	VLOAD1	1mA≤IOUT≤150mA		10	40	mV
Load Regulation 2	VLOAD2	1mA≤IOUT≤200mA		20	60	mV
Dropout Voltage	ViO	Please refer to another page				V
Ripple Rejection (Note5)	RR	f=1kHz, Vripple=0.5V, IOUT=10mA		70		dB
VOUT Temperature Coefficient (Note5)	ΔVOUT/ΔT	IOUT=10mA, -40≤Top≤85°C		±100		ppm/°C
Output Current Limit	Ilim		200	350		mA
Output Short-Circuit Current (Note5)	Ishort	VOUT=0V		20		mA
CE High Threshold Voltage	VCEH		1.5		VDD	V
CE Low Threshold Voltage	VCEL				0.3	V
CE High Threshold Current	ICEH		-1.0		+1.0	μA
CE Low Threshold Current	ICEL		-1.0		+1.0	μA
CL Discharge Resistance (Note5)	Rdisc	VCE=0V, VDD=6V		10		Ω

Note5 : The parameter is guaranteed by design.

• Any products mentioned in this catalog are subject to any modification in their appearance and others for improvements without prior notification.
 • The details listed here are not a guarantee of the individual products at the time of ordering. When using the products, you will be asked to check their specifications.

Electrical Characteristics 2 (Except where noted otherwise $V_{DD}=V_{OUT}(TYP.)+1V$, $V_{CE}=V_{DD}$, $T_a=25^{\circ}C$)

Model No.	Item							
	Output Voltage				Dropout Voltage			
	V_{OUT} (V)				V_{OUT} (V)			
	Measurement Conditions	Min.	Typ.	Max.	Measurement Conditions	Min.	Typ.	Max.
MM3411A08	$I_{OUT}=10mA$	0.780	0.800	0.820	$I_{OUT}=150mA$ $0.8V \leq V_{OUT} < 1.9V$ (Note6)		0.77	0.88
MM3411A09		0.880	0.900	0.920				
MM3411A10		0.980	1.000	1.020				
MM3411A11		1.080	1.100	1.120			0.69	0.79
MM3411A12		1.180	1.200	1.220				
MM3411A13		1.280	1.300	1.320				
MM3411A14		1.380	1.400	1.420			0.60	0.70
MM3411A15		1.480	1.500	1.520				
MM3411A16		1.580	1.600	1.620				
MM3411A17		1.680	1.700	1.720			0.51	0.61
MM3411A18		1.780	1.800	1.820				
MM3411A19		1.880	1.900	1.920				
MM3411A20		1.980	2.000	2.020				
MM3411A21		2.079	2.100	2.121			0.47	0.57
MM3411A22		2.178	2.200	2.222				
MM3411A23		2.277	2.300	2.323				
MM3411A24		2.376	2.400	2.424				
MM3411A25		2.475	2.500	2.525				
MM3411A26		2.574	2.600	2.626				
MM3411A27		2.673	2.700	2.727				
MM3411A28		2.772	2.800	2.828				
MM3411A29		2.871	2.900	2.929		0.31	0.41	
MM3411A30		2.970	3.000	3.030				
MM3411A31		3.069	3.100	3.131				
MM3411A32		3.168	3.200	3.232				
MM3411A33		3.267	3.300	3.333	$I_{OUT}=150mA$ $1.9V \leq V_{OUT} \leq 5.0V$ $V_{DD}=V_{OUT}(TYP.)-0.2V$			
MM3411A34		3.366	3.400	3.434				
MM3411A35		3.465	3.500	3.535				
MM3411A36		3.564	3.600	3.636				
MM3411A37		3.663	3.700	3.737				
MM3411A38		3.762	3.800	3.838				
MM3411A39		3.861	3.900	3.939				
MM3411A40	3.960	4.000	4.040			0.23	0.33	
MM3411A41	4.059	4.100	4.141					
MM3411A42	4.158	4.200	4.242					
MM3411A43	4.257	4.300	4.343					
MM3411A44	4.356	4.400	4.444					
MM3411A45	4.455	4.500	4.545					
MM3411A46	4.554	4.600	4.646					
MM3411A47	4.653	4.700	4.747					
MM3411A48	4.752	4.800	4.848		0.19	0.28		
MM3411A49	4.851	4.900	4.949					
MM3411A50	4.950	5.000	5.050					

Note6 : Dropout voltage maximum value in the input and it is confirmed that there is no output abnormal voltage impression the 150mA in the model less than $V_{OUT} < 1.9V$.

• Any products mentioned in this catalog are subject to any modification in their appearance and others for improvements without prior notification.
 • The details listed here are not a guarantee of the individual products at the time of ordering. When using the products, you will be asked to check their specifications.

Model No.	Item								
	Output Voltage				Dropout Voltage				
	V _{OUT} (V)				V _{OUT} (V)				
	Measurement Conditions	Min.	Typ.	Max.	Measurement Conditions	Min.	Typ.	Max.	
MM3411Z08	I _{OUT} =10mA	0.830	0.850	0.870	I _{OUT} =150mA 0.8V ≤ V _{OUT} < 1.9V (Note6)		0.77	0.88	
MM3411Z09		0.930	0.950	0.970					
MM3411Z10		1.030	1.050	1.070					
MM3411Z11		1.130	1.150	1.170			0.69	0.79	
MM3411Z12		1.230	1.250	1.270					
MM3411Z13		1.330	1.350	1.370					
MM3411Z14		1.430	1.450	1.470			0.60	0.70	
MM3411Z15		1.530	1.550	1.570					
MM3411Z16		1.630	1.650	1.670					
MM3411Z17		1.730	1.750	1.770			0.51	0.61	
MM3411Z18		1.830	1.850	1.870					
MM3411Z19		1.930	1.950	1.970		I _{OUT} =150mA 1.9V ≤ V _{OUT} ≤ 5.0V V _{DD} =V _{OUT} (TYP.) -0.2V			
MM3411Z20		2.030	2.050	2.071					
MM3411Z21		2.129	2.150	2.172				0.47	0.57
MM3411Z22		2.228	2.250	2.273					
MM3411Z23		2.327	2.350	2.374					
MM3411Z24		2.426	2.450	2.475					
MM3411Z25		2.525	2.550	2.576					
MM3411Z26		2.624	2.650	2.677					
MM3411Z27		2.723	2.750	2.778					
MM3411Z28		2.822	2.850	2.879					
MM3411Z29		2.921	2.950	2.980			0.31	0.41	
MM3411Z30		3.020	3.050	3.081					
MM3411Z31		3.119	3.150	3.182					
MM3411Z32		3.218	3.250	3.283					
MM3411Z33		3.317	3.350	3.384					
MM3411Z34		3.416	3.450	3.485					
MM3411Z35		3.515	3.550	3.586					
MM3411Z36		3.614	3.650	3.687					
MM3411Z37		3.713	3.750	3.788					
MM3411Z38	3.812	3.850	3.889						
MM3411Z39	3.911	3.950	3.990		0.23	0.33			
MM3411Z40	4.010	4.050	4.091						
MM3411Z41	4.109	4.150	4.192						
MM3411Z42	4.208	4.250	4.293						
MM3411Z43	4.307	4.350	4.394						
MM3411Z44	4.406	4.450	4.495						
MM3411Z45	4.505	4.550	4.596						
MM3411Z46	4.604	4.650	4.697						
MM3411Z47	4.703	4.750	4.798		0.19	0.28			
MM3411Z48	4.802	4.850	4.899						
MM3411Z49	4.901	4.950	5.000						

Note6 : Dropout voltage maximum value in the input and it is confirmed that there is no output abnormal voltage impression the 150mA in the model less than V_{OUT}<1.9V.

Electrical Characteristics 3 (Except where noted otherwise $V_{DD}=V_{OUT}(TYP.)+1V$, $V_{CE}=V_{DD}$, $T_a=25^{\circ}C$)

Model No.	Item							
	Output Voltage				Dropout Voltage			
	V_{OUT} (V)				V_{OUT} (V)			
	Measurement Conditions	Min.	Typ.	Max.	Measurement Conditions	Min.	Typ.	Max.
MM3411A08	$I_{OUT}=10mA$	0.780	0.800	0.820	$I_{OUT}=200mA$ $0.8V \leq V_{OUT} < 1.9V$ (Note7)			
MM3411A09		0.880	0.900	0.920			1.00	1.15
MM3411A10		0.980	1.000	1.020				
MM3411A11		1.080	1.100	1.120			0.90	1.04
MM3411A12		1.180	1.200	1.220				
MM3411A13		1.280	1.300	1.320				
MM3411A14		1.380	1.400	1.420			0.78	0.90
MM3411A15		1.480	1.500	1.520				
MM3411A16		1.580	1.600	1.620				
MM3411A17		1.680	1.700	1.720			0.67	0.77
MM3411A18		1.780	1.800	1.820				
MM3411A19		1.880	1.900	1.920				
MM3411A20		1.980	2.000	2.020				
MM3411A21		2.079	2.100	2.121			0.62	0.72
MM3411A22		2.178	2.200	2.222				
MM3411A23		2.277	2.300	2.323				
MM3411A24		2.376	2.400	2.424				
MM3411A25		2.475	2.500	2.525				
MM3411A26		2.574	2.600	2.626				
MM3411A27		2.673	2.700	2.727				
MM3411A28		2.772	2.800	2.828				
MM3411A29		2.871	2.900	2.929		0.40	0.50	
MM3411A30		2.970	3.000	3.030				
MM3411A31		3.069	3.100	3.131				
MM3411A32		3.168	3.200	3.232				
MM3411A33		3.267	3.300	3.333	$I_{OUT}=200mA$ $1.9V \leq V_{OUT} \leq 5.0V$ $V_{DD}=V_{OUT}(TYP.)-0.2V$			
MM3411A34		3.366	3.400	3.434				
MM3411A35		3.465	3.500	3.535				
MM3411A36		3.564	3.600	3.636				
MM3411A37		3.663	3.700	3.737				
MM3411A38		3.762	3.800	3.838				
MM3411A39		3.861	3.900	3.939				
MM3411A40	3.960	4.000	4.040			0.30	0.40	
MM3411A41	4.059	4.100	4.141					
MM3411A42	4.158	4.200	4.242					
MM3411A43	4.257	4.300	4.343					
MM3411A44	4.356	4.400	4.444					
MM3411A45	4.455	4.500	4.545					
MM3411A46	4.554	4.600	4.646					
MM3411A47	4.653	4.700	4.747					
MM3411A48	4.752	4.800	4.848		0.25	0.34		
MM3411A49	4.851	4.900	4.949					
MM3411A50	4.950	5.000	5.050					

Note7 : Dropout voltage maximum value in the input and it is confirmed that there is no output abnormal voltage impression the 200mA in the model less than $V_{OUT} < 1.9V$.

• Any products mentioned in this catalog are subject to any modification in their appearance and others for improvements without prior notification.
 • The details listed here are not a guarantee of the individual products at the time of ordering. When using the products, you will be asked to check their specifications.

Model No.	Item								
	Output Voltage				Dropout Voltage				
	V _{OUT} (V)				V _{OUT} (V)				
	Measurement Conditions	Min.	Typ.	Max.	Measurement Conditions	Min.	Typ.	Max.	
MM3411Z08	I _{OUT} =10mA	0.830	0.850	0.870	I _{OUT} =200mA 0.8V ≤ V _{OUT} < 1.9V (Note7)		1.00	1.15	
MM3411Z09		0.930	0.950	0.970					
MM3411Z10		1.030	1.050	1.070					
MM3411Z11		1.130	1.150	1.170			0.90	1.04	
MM3411Z12		1.230	1.250	1.270					
MM3411Z13		1.330	1.350	1.370					
MM3411Z14		1.430	1.450	1.470			0.78	0.90	
MM3411Z15		1.530	1.550	1.570					
MM3411Z16		1.630	1.650	1.670					
MM3411Z17		1.730	1.750	1.770			0.67	0.77	
MM3411Z18		1.830	1.850	1.870					
MM3411Z19		1.930	1.950	1.970		I _{OUT} =200mA 1.9V ≤ V _{OUT} ≤ 5.0V V _{DD} =V _{OUT} (TYP.) -0.2V		0.62	0.72
MM3411Z20		2.030	2.050	2.071					
MM3411Z21		2.129	2.150	2.172					
MM3411Z22		2.228	2.250	2.273					
MM3411Z23		2.327	2.350	2.374					
MM3411Z24		2.426	2.450	2.475					
MM3411Z25		2.525	2.550	2.576					
MM3411Z26		2.624	2.650	2.677					
MM3411Z27		2.723	2.750	2.778					
MM3411Z28		2.822	2.850	2.879					
MM3411Z29		2.921	2.950	2.980			0.40	0.50	
MM3411Z30		3.020	3.050	3.081					
MM3411Z31		3.119	3.150	3.182					
MM3411Z32		3.218	3.250	3.283					
MM3411Z33		3.317	3.350	3.384					
MM3411Z34		3.416	3.450	3.485					
MM3411Z35		3.515	3.550	3.586					
MM3411Z36		3.614	3.650	3.687					
MM3411Z37		3.713	3.750	3.788					
MM3411Z38		3.812	3.850	3.889					
MM3411Z39		3.911	3.950	3.990		0.30	0.40		
MM3411Z40	4.010	4.050	4.091						
MM3411Z41	4.109	4.150	4.192						
MM3411Z42	4.208	4.250	4.293						
MM3411Z43	4.307	4.350	4.394						
MM3411Z44	4.406	4.450	4.495						
MM3411Z45	4.505	4.550	4.596						
MM3411Z46	4.604	4.650	4.697						
MM3411Z47	4.703	4.750	4.798		0.25	0.34			
MM3411Z48	4.802	4.850	4.899						
MM3411Z49	4.901	4.950	5.000						

Note7 : Dropout voltage maximum value in the input and it is confirmed that there is no output abnormal voltage impression the 200mA in the model less than V_{OUT}<1.9V.

Measuring Circuit

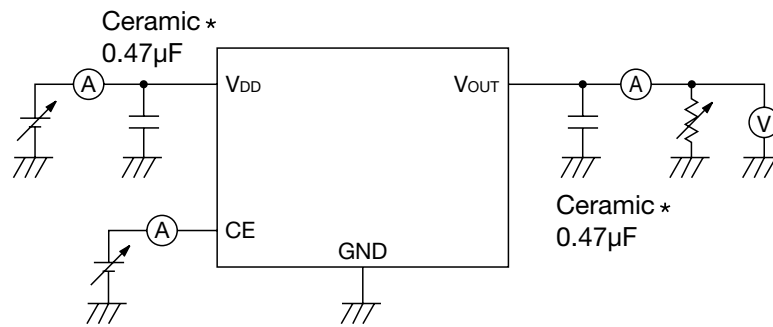

Application Circuit

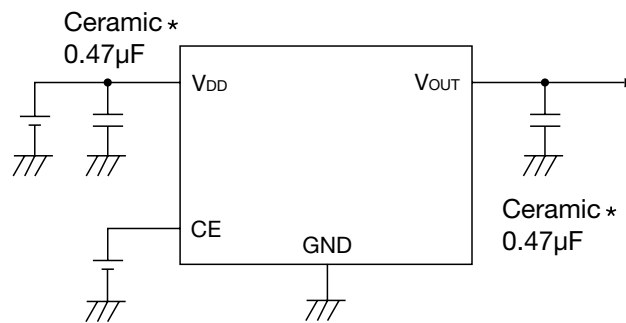

* Temperature Characteristics : B

(Reference example of external parts)

- Output capacitor Ceramic capacitor 0.47μF
- Input capacitor Ceramic capacitor 0.47μF

· We shall not be liable for any trouble or damage caused by using this circuit.

· In the event a problem which may affect industrial property or any other rights of us or a third party is encountered during the use of information described in these circuit, we shall not be liable for any such problem, nor grant a license therefore.

· Note

1. Please use this IC within the stated absolute maximum ratings.
The IC is liable to malfunction should the ratings be exceeded.
2. Due to restrictions on the package power dissipation, the output current value may not be satisfied.
Attention should be paid to the power dissipation of the package when the output current is large or the voltage between Input and Output is high.
3. The output capacitor is required between output and GND to prevent oscillation.
4. The ESR of capacitor must be defined in ESR stability area. It is possible to use a ceramic capacitor without ESR resistance for output. The ceramic capacitor must be used more than 0.47μF and B temperature characteristics.
5. The wire of VDD and GND is required to print full ground plane for noise and stability.
6. The input capacitor must be connected a distance of less than 1cm from input pin.
7. It is able to oscillation when you use the capacitor with intense capacitance change such as micro.
Please evaluate IC in the set.

- 8. In case the output voltage is above the input voltage, the overcurrent flow by internal parastic diode from output to input. In such application, the external bypass diode must be connected between output and input pin.
- 9. This IC will limit the output current with the overcurrent protection circuit when the overcurrent and the output do short-circuit.

However, IC generates heat because of the substrate and use conditions and there is a possibility of destroying it exceeding a permissible loss.

The characteristic changes depending on the substrate condition. Please evaluate IC in the set.

- 10. In case the output capacitor is over 2.2μF and steady current is under 5mA, it is able to oscillate. It is recommended that the output capacitor is under 2.2μF on condition that the current is under 5mA. Please evaluate IC in the set if it is used in the above condition.

Complement : The oscillation is low level noise (200~300μVrms/Vout=3.0V).
 So the above condition is recommended only if it is used for a sensitive sensor against noise.
 Except for sensitive part against noise, the restriction of above condition is not required.

About Power Dissipation

The Power dissipation change if board to mount IC change because radiative heat fix at board. It is reference data below, Evaluate IC in the set.

MM3411AxxRRE

- 1. PC Board of glass epoxy

Board size 100mm×100mm t=1.6mm Copper foil area 80%
 Power dissipation 850mW Ta=25°C

- 2. JEDEC51-7 standard

Board size 114.3mm×76.2mm t=1.6mm Copper foil area 80%
 Power dissipation 1300mW Ta=25°C (It is reference value measured by JEDEC51-7 standard.)

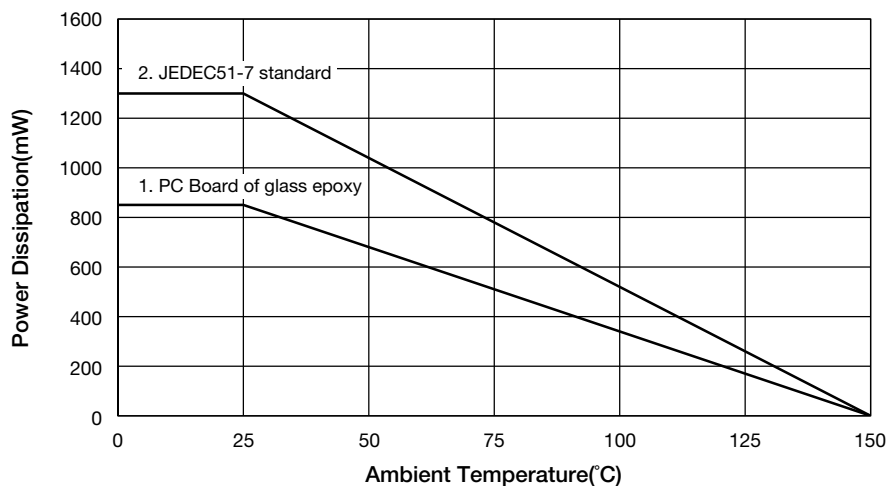

MM3411AxxURE

1. PC Board of glass epoxy

Board size 100mm×100mm t=1.6mm Copper foil area 10%
 Power dissipation 330mW Ta=25°C

2. JEDEC51-7 standard

Board size 114.3mm×76.2mm t=1.6mm Copper foil area 80%
 Power dissipation 650mW Ta=25°C (It is reference value measured by JEDEC51-7 standard.)

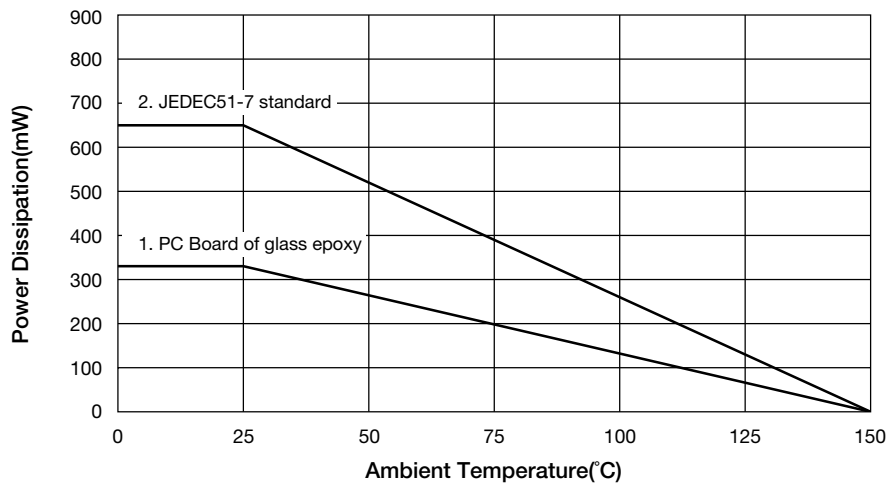

MM3411AxxNRE

1. PC Board of glass epoxy

Board size 60mm×40mm t=1.6mm Copper foil area 60%
 Power dissipation 350mW Ta=25°C

2. JEDEC51-7 standard

Board size 114.3mm×76.2mm t=1.6mm Copper foil area 80%
 Power dissipation 700mW Ta=25°C (It is reference value measured by JEDEC51-7 standard.)

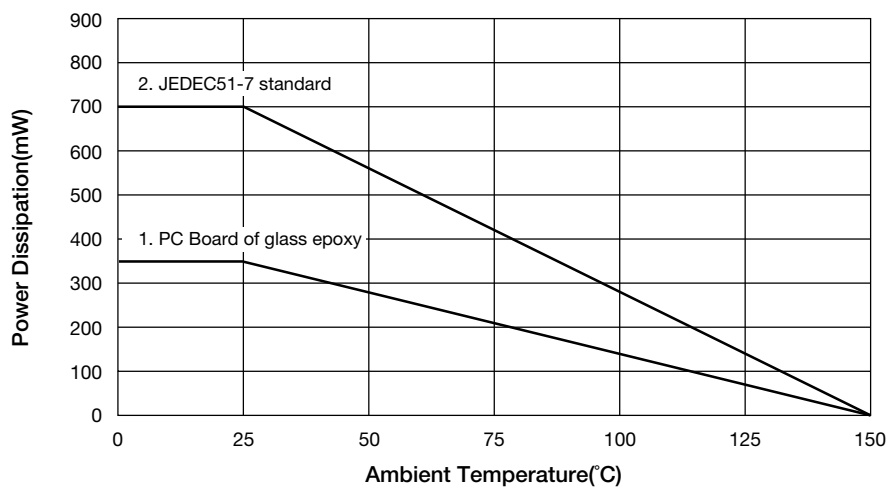

It is recommended to layout the VIA for heat radiation in the GND pattern of reverse (of IC) when there is the GND pattern in the inner layer (in using multilayer substrate).

By increasing these copper foil pattern area of PCB, Power dissipation improves.

• Any products mentioned in this catalog are subject to any modification in their appearance and others for improvements without prior notification.
 • The details listed here are not a guarantee of the individual products at the time of ordering. When using the products, you will be asked to check their specifications.

Characteristics (V_{OUT}=0.8V) (Except where noted otherwise V_{DD}=V_{OUT}(TYP.)+1V, V_{CE}=V_{DD}, Ta=25°C)

Input Voltage - Output Voltage

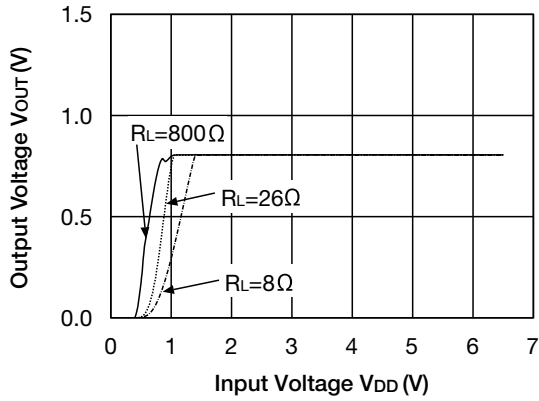

Input Voltage - Input Current

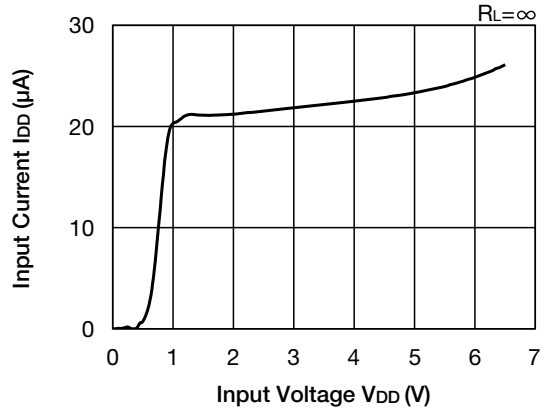

Load Regulation

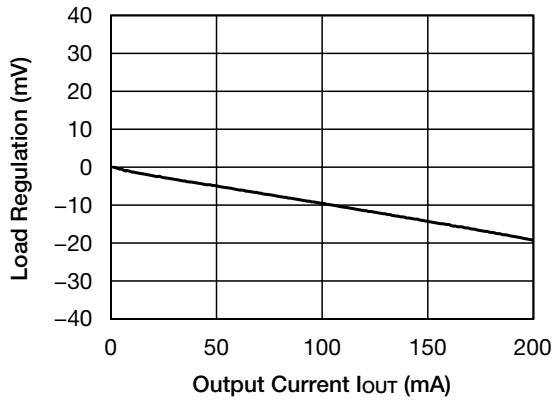

Line Regulation

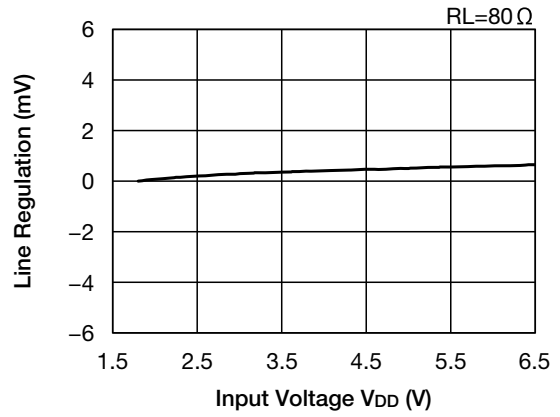

Vout Temperature Coefficient

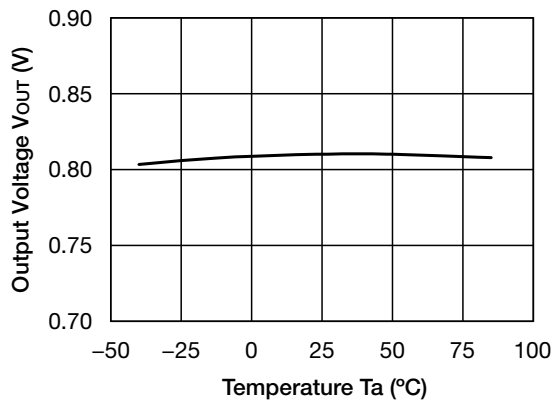

• Any products mentioned in this catalog are subject to any modification in their appearance and others for improvements without prior notification.
 • The details listed here are not a guarantee of the individual products at the time of ordering. When using the products, you will be asked to check their specifications.

Ripple Rejection

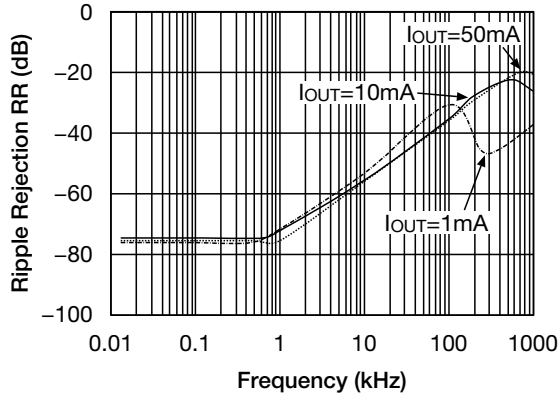

ESR stable area

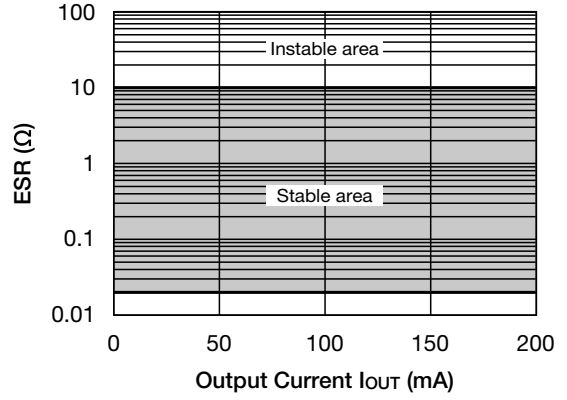

Current Limit

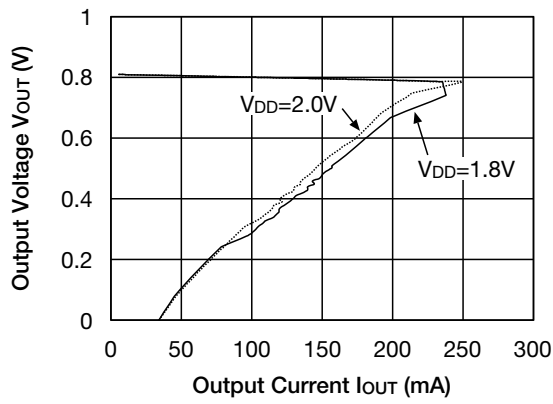

Load Transient response
 ($V_{DD}=V_{OUT}+1V$, $V_{CE}=V_{DD}$, $C_{in}=C_{out}=0.47\mu F$)

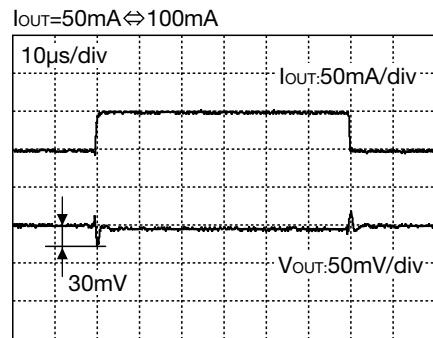
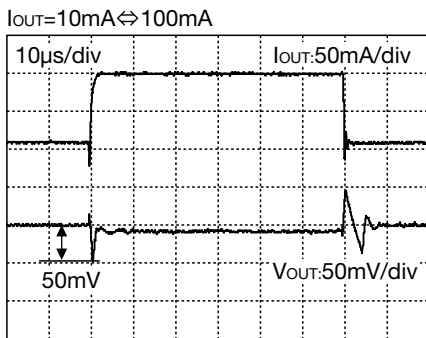
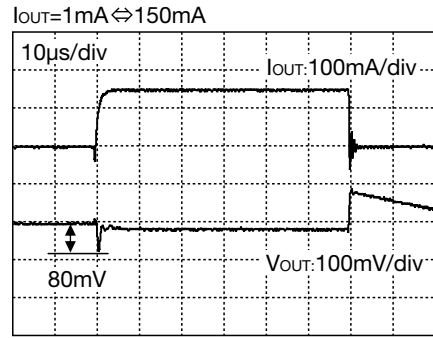
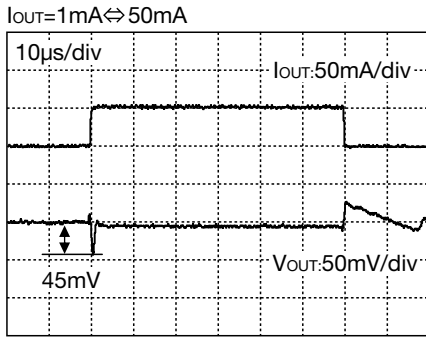

CE Transient
 ($V_{DD}=1.8V$, $V_{CE}=0V \rightarrow V_{DD}$, $C_O=0.47\mu F$)

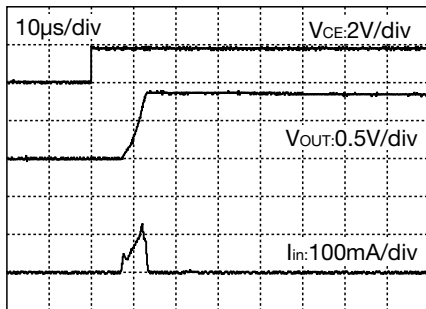

CE Transient
 ($V_{DD}=1.8V$, $V_{CE}=0V \rightarrow V_{DD}$, $C_O=10\mu F$)

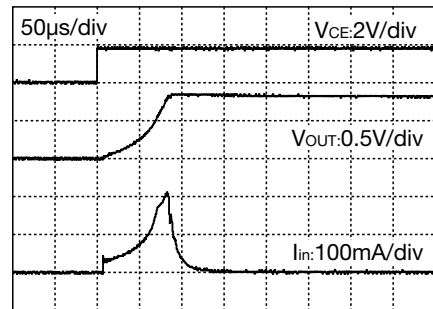

Output Rise Time

($V_{DD}=V_{OUT}+1V$, $V_{CE}=0V \rightarrow V_{DD}$, $C_{in}=0.47\mu F$)

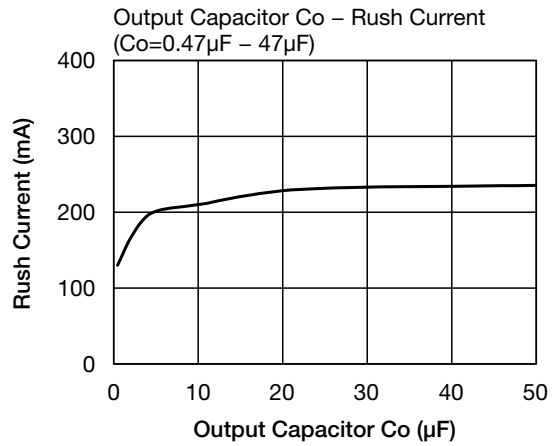
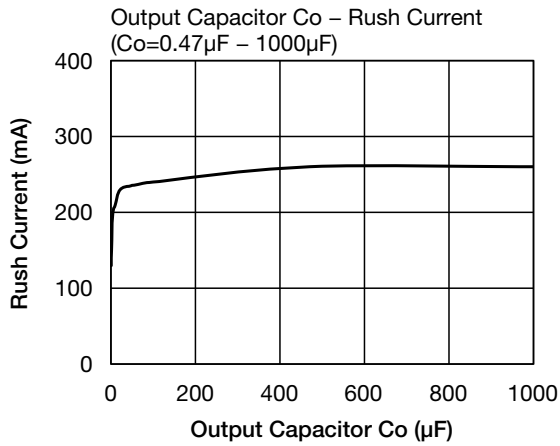
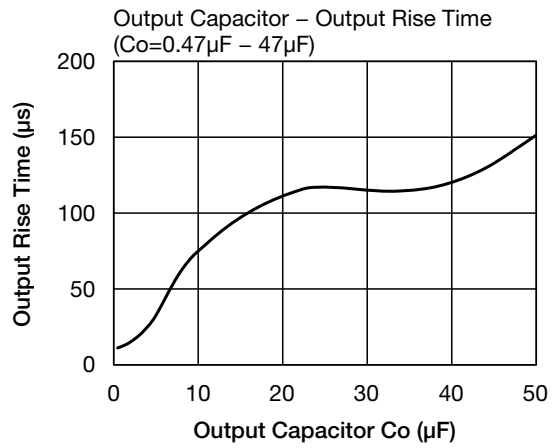
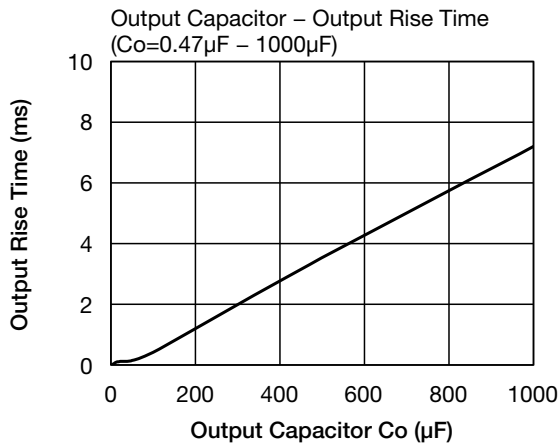

Characteristics (V_{OUT}=3.0V) (Except where noted otherwise V_{DD}=V_{OUT}(TYP.)+1V, V_{CE}=V_{DD}, Ta=25°C)

Input Voltage - Output Voltage

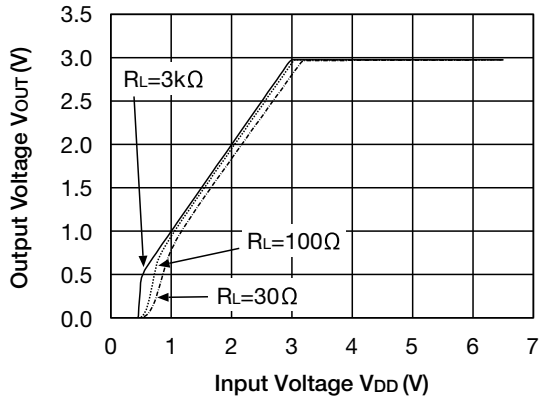

Input Voltage - Input Current

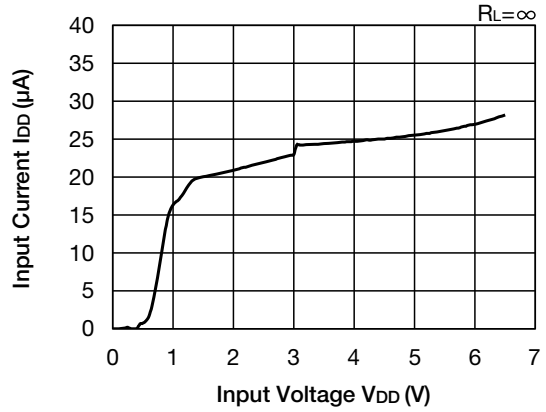

Load Regulation

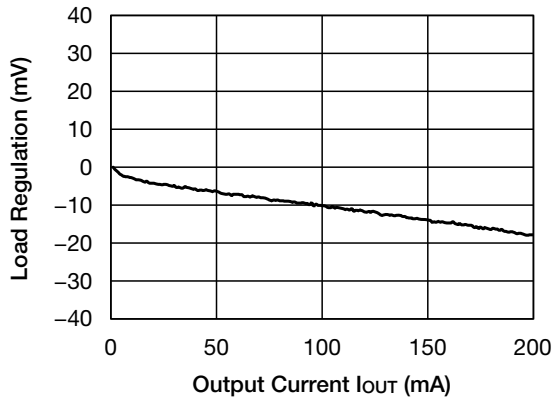

Line Regulation

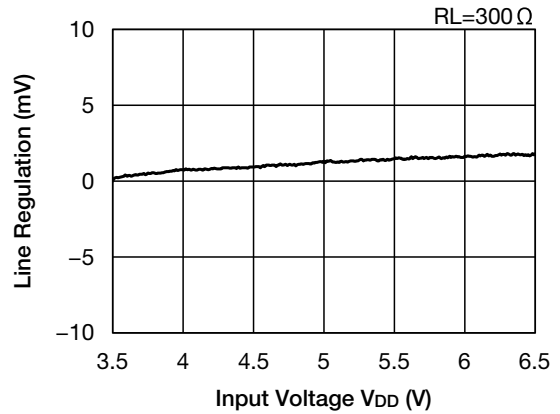

Dropout Voltage

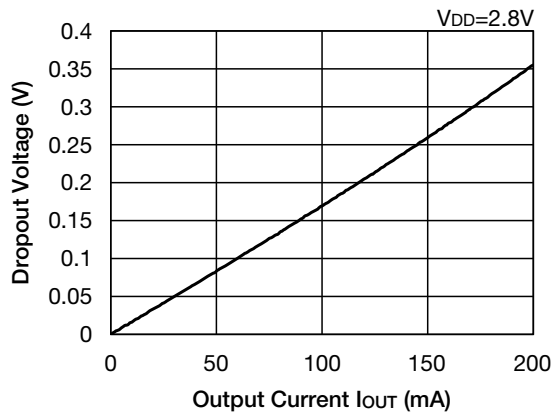

Vout Temperature Coefficient

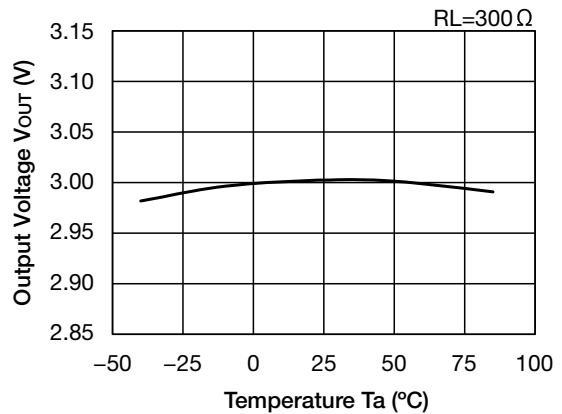

■ Ripple Rejection

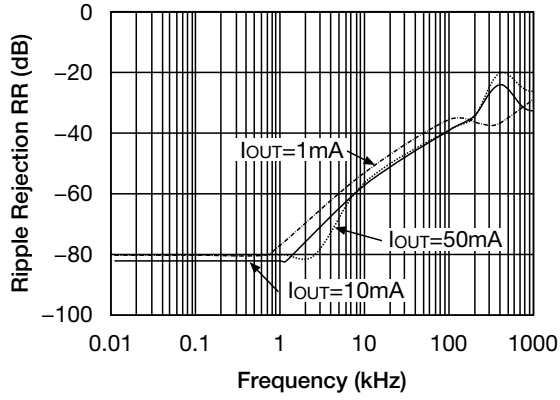

■ ESR stable area

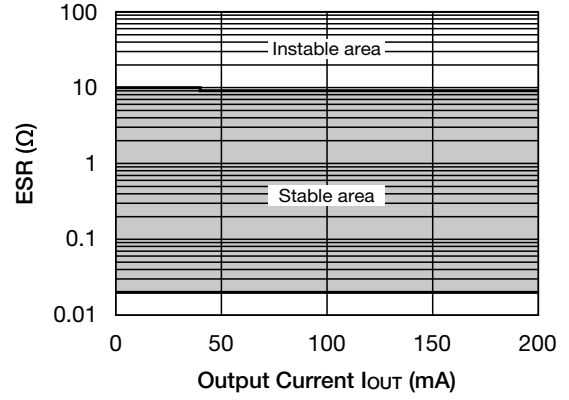

■ Current Limit

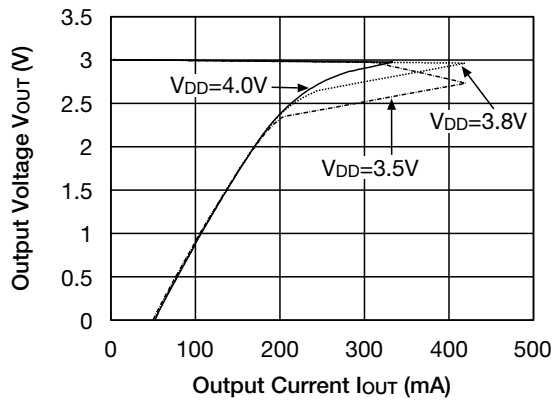

Load Transient response
 ($V_{DD}=V_{OUT}+1V$, $V_{CE}=V_{DD}$, $C_{in}=C_{out}=0.47\mu F$)

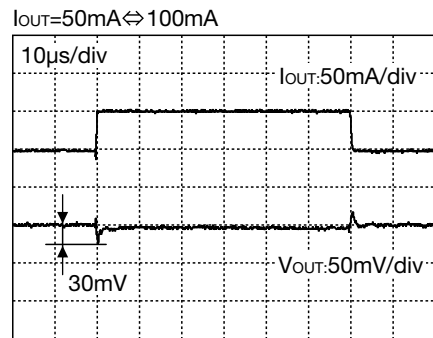
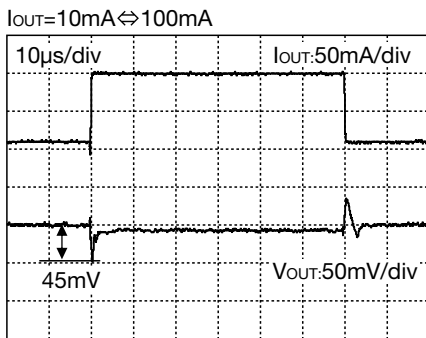
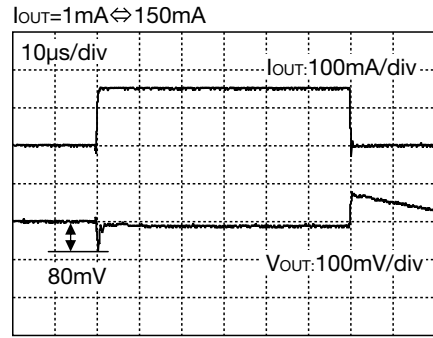
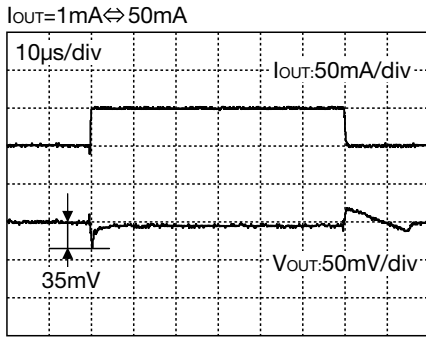

CE Transient
 ($V_{DD}=4.0V$, $V_{CE}=0V \rightarrow V_{DD}$, $C_O=0.47\mu F$)

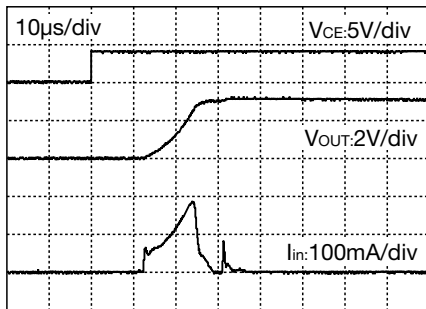

CE Transient
 ($V_{DD}=4.0V$, $V_{CE}=0V \rightarrow V_{DD}$, $C_O=10\mu F$)

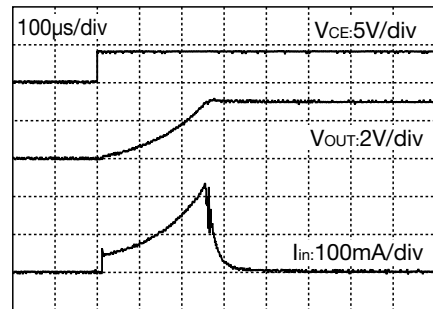

Output Rise Time

($V_{DD}=V_{OUT}+1V$, $V_{CE}=0V \rightarrow V_{DD}$, $C_{in}=0.47\mu F$)

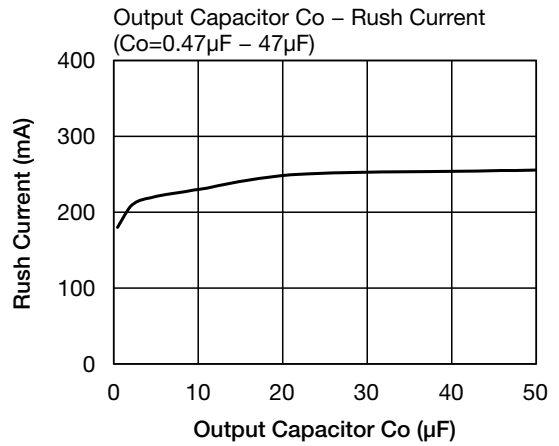
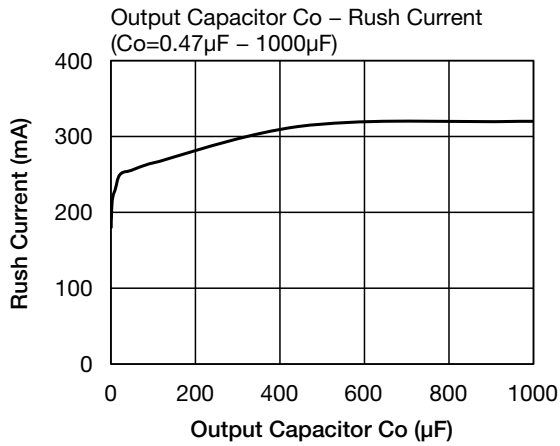
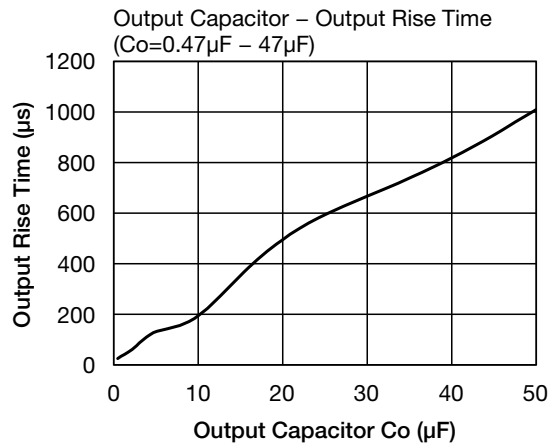
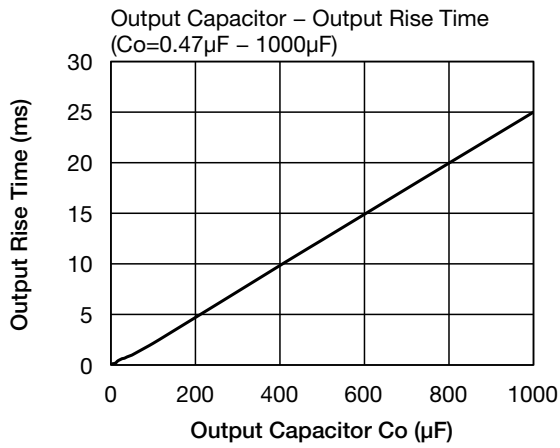

Characteristics (V_{OUT}=5.0V) (Except where noted otherwise V_{DD}=V_{OUT}(TYP.)+1V, V_{CE}=V_{DD}, Ta=25°C)

Input Voltage - Output Voltage

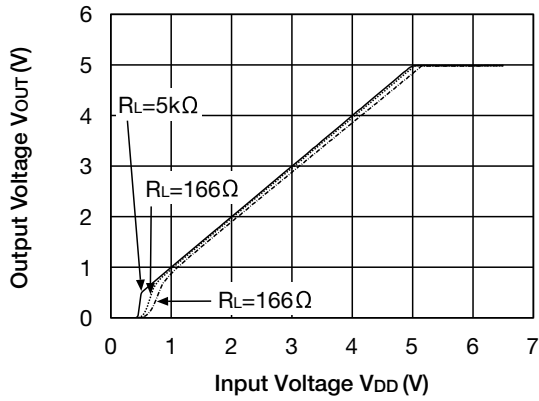

Input Voltage - Input Current

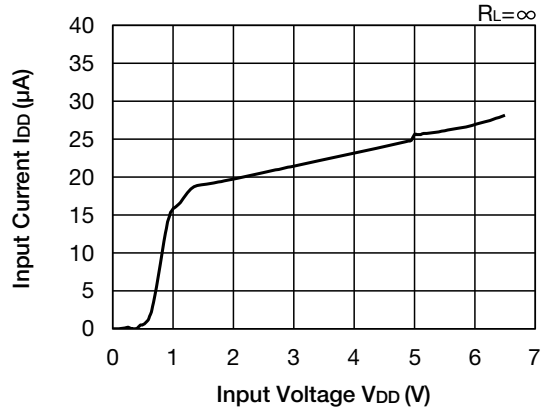

Load Regulation

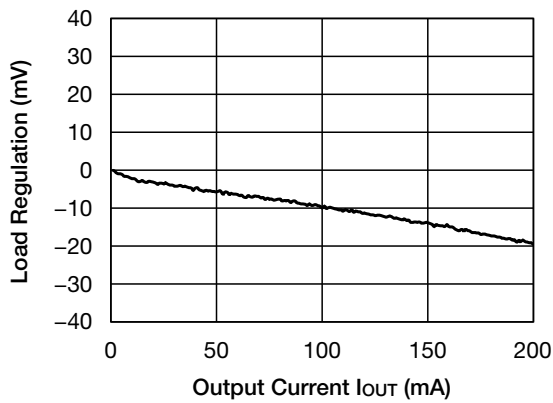

Line Regulation

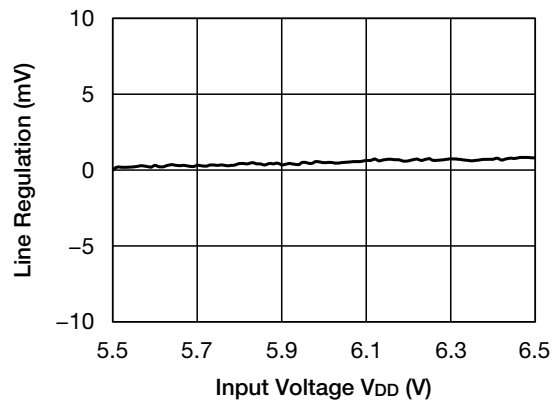

Dropout Voltage

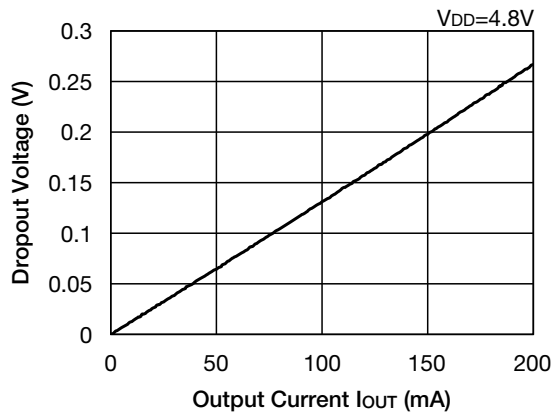

Vout Temperature Coefficient

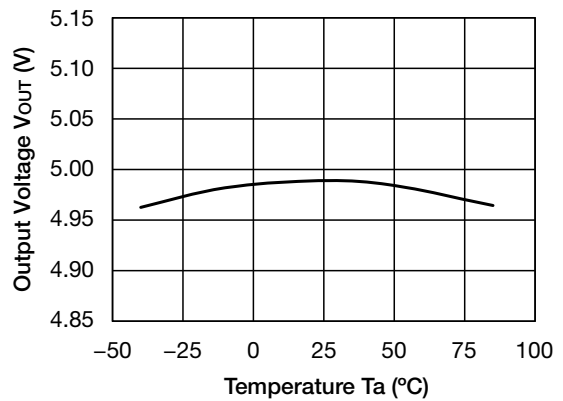

• Any products mentioned in this catalog are subject to any modification in their appearance and others for improvements without prior notification.
 • The details listed here are not a guarantee of the individual products at the time of ordering. When using the products, you will be asked to check their specifications.

Ripple Rejection

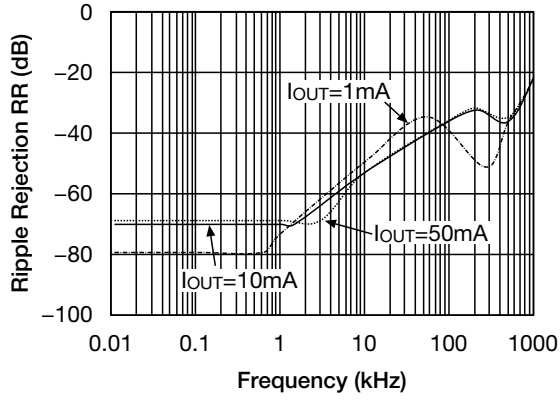

ESR stable area

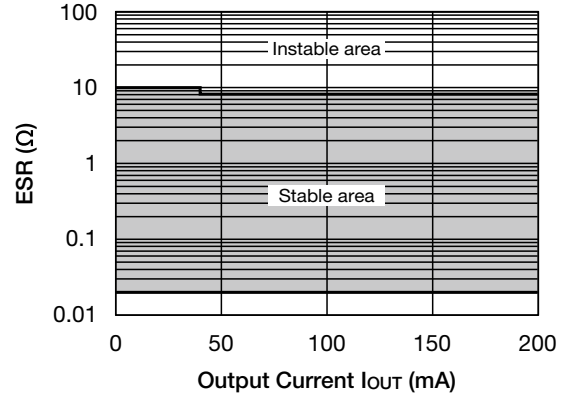

Current Limit

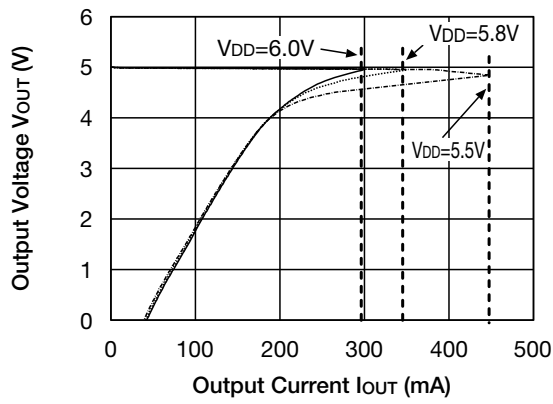

• Any products mentioned in this catalog are subject to any modification in their appearance and others for improvements without prior notification.
 • The details listed here are not a guarantee of the individual products at the time of ordering. When using the products, you will be asked to check their specifications.

Load Transient response
 ($V_{DD}=V_{OUT}+1V$, $V_{CE}=V_{DD}$, $C_{in}=C_{out}=0.47\mu F$)

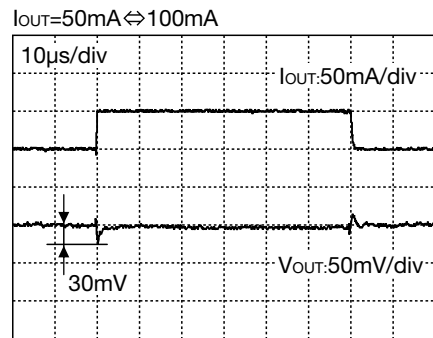
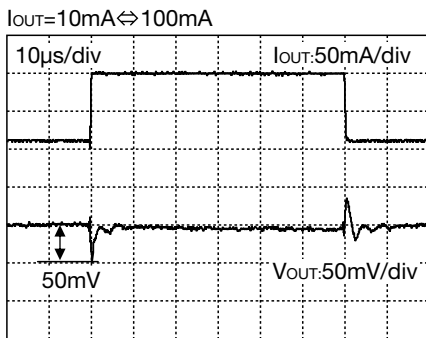
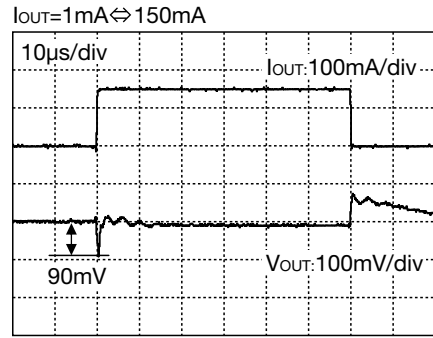
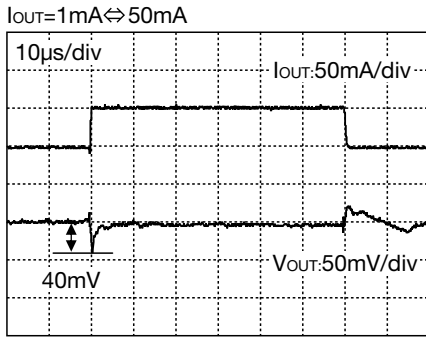

CE Transient
 ($V_{DD}=6.0V$, $V_{CE}=0V \rightarrow V_{DD}$, $C_O=0.47\mu F$)

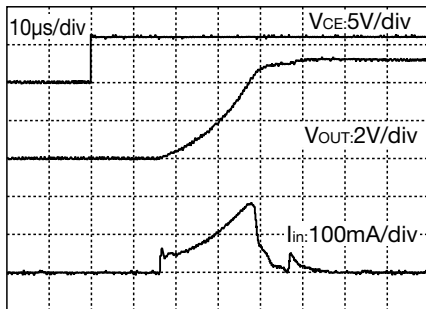

CE Transient
 ($V_{DD}=6.0V$, $V_{CE}=0V \rightarrow V_{DD}$, $C_O=10\mu F$)

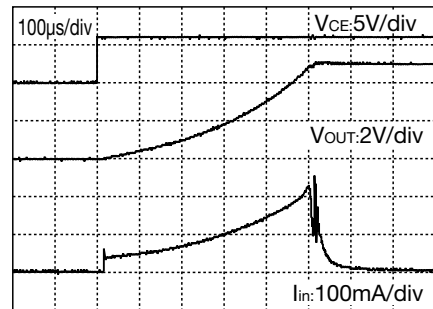

Output Rise Time

($V_{DD}=V_{OUT}+1V$, $V_{CE}=0V \rightarrow V_{DD}$, $C_{in}=0.47\mu F$)

