

200mA Regulator IC Monolithic IC MM3404 Series

Outline

This IC is a high speed response 200mA regulator IC with low quiescent current and high ripple rejection. No load input current is 20 μ A typ. And ripple rejection is 75dB typ. Dropout voltage is low at 80mV typ., and the output current is 200mA. Therefore the IC applies to most mobile equipment.

Features

1. Output current	200mA
2. No load input current	20 μ A typ.
3. Input current(OFF)	0.1 μ A max.
4. Output voltage range	0.8~5.0V
5. Output voltage accuracy	\pm 1% (\pm 20mV, $V_o < 2V$)
6. Dropout voltage	80mV typ. ($I_o = 100mA$)
7. Line regulation	0.2%/V max.
8. Load regulation	40mV max. ($I_o = 0.1 \sim 100mA$)
9. Ripple rejection	75dB typ. ($f = 1kHz$)
10. Output capacitor	1 μ F

Package

SOT-25A
SC-82
PLP-4B

Applications

1. Cellular phones
2. Digital still cameras
3. Mobile equipments

Block Diagram

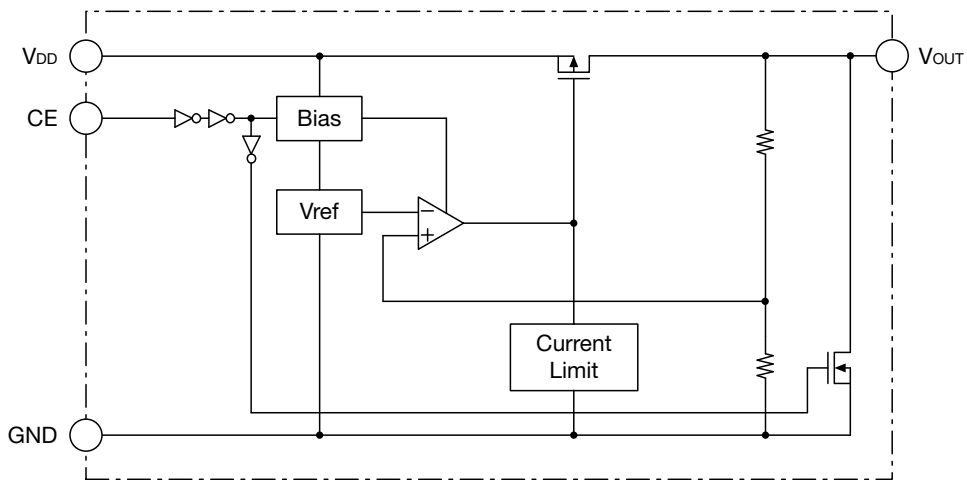

Pin Assignment

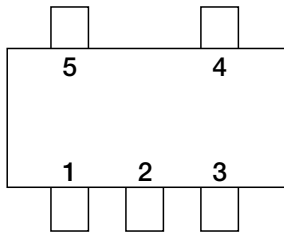

SOT-25A
(TOP VIEW)

1	V _{DD}
2	GND
3	CE
4	NC
5	V _{OUT}

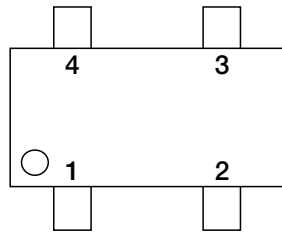

SC-82
(TOP VIEW)

1	CE
2	GND
3	V _{OUT}
4	V _{DD}

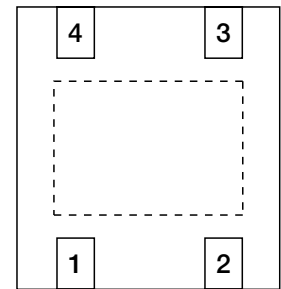

PLP-4B
(TOP VIEW)

1	V _{OUT}
2	GND
3	CE
4	V _{DD}

Pin Description

SOT-25A

Pin No.	Pin name	Functions
1	V _{DD}	Voltage-supply pin
2	GND	Ground pin
3	CE	ON/OFF-Control pin
		CE OUTPUT
		Low OFF
		High ON
Connect CE pin with V _{DD} pin, when it is not used.		
4	NC	No connection
5	V _{OUT}	Output pin

SC-82

Pin No.	Pin name	Functions
1	CE	ON/OFF-Control pin
		CE OUTPUT
		Low OFF
		High ON
Connect CE pin with V _{DD} pin, when it is not used.		
2	GND	Ground pin
3	V _{OUT}	Output pin
4	V _{DD}	Voltage-Supply pin

PLP-4B

Pin No.	Pin name	Functions
1	V _{OUT}	Output pin
2	GND	Ground pin
3	CE	ON/OFF-Control pin
		CE OUTPUT
		Low OFF
		High ON
Connect CE pin with V _{DD} pin, when it is not used.		
4	V _{DD}	Voltage-supply pin

Absolute Maximum Ratings (Except where noted otherwise Ta=25°C)

Item	Symbol	Ratings	Units
Storage temperature	T _{STG}	-55~+150	°C
Supply voltage	V _{DD}	-0.3~7.0	V
CE input voltage	V _{CE}	-0.3~V _{DD} +0.3	V
Output voltage	V _{OUT}	-0.3~V _{DD} +0.3	V
Output current	I _{o max.}	400	mA
Power dissipation	Pd	350(Note1) (SOT-25A)	mW
		330(Note2) (SC-82)	
		120(Note3) (PLP-4B)	

Note1 : With PC Board of glass epoxy 60 × 40 × 1.6^tmm

Note2 : With PC Board of glass epoxy 110 × 40 × 0.8^tmm

Note3 : Single device

Recommended Operating Conditions (Except where noted otherwise Ta=25°C)

Item	Symbol	Ratings	Units
Operating ambient temperature	T _{JOP}	-40~85	°C
Operating voltage	V _{OP}	1.6~6.5	V
Output current	I _o	0~200	mA

• Any products mentioned in this catalog are subject to any modification in their appearance and others for improvements without prior notification.
 • The details listed here are not a guarantee of the individual products at the time of ordering. When using the products, you will be asked to check their specifications.

Electrical Characteristics 1 (Except where noted otherwise $V_{DD}=V_{OUT}(typ.)+1V$, $V_{CE}=V_{DD}$, $T_a=25^{\circ}C$)

Item	Symbol	Measurement conditions	Min.	Typ.	Max.	Units
Input current(OFF)	I_{DDoff}	$V_{CE}=0V$		0.01	0.1	μA
No-load input current	I_{DD}	$I_{OUT}=0mA$		20	50	μA
Output voltage	V_{OUT}	$I_{OUT}=10mA$ ($V_{OUT} \geq 2.0V$)	$\times 0.99$		$\times 1.01$	V
		$I_{OUT}=10mA$ ($V_{OUT} \leq 1.95V$)	-0.02		0.02	v
Line regulation	V_{LINE}	$V_O(yp.)+0.5V \leq V_{DD} \leq 6.5V$ $V_{OUT} \geq 1.1V, I_{OUT}=10mA$		0.01	0.2	% / V
		$1.6V \leq V_{DD} \leq 6.5V$ $V_{OUT} \leq 1.05V, I_{OUT}=10mA$				
Load regulation	V_{LOAD}	$0.1mA \leq I_{OUT} \leq 100mA$		10	40	mV
Dropout voltage	V_{io}	Please refer to another page				V
Ripple rejection (Note4)	RR	$f=1kHz, V_{ripple}=0.5V, I_{OUT}=30mA$ $V_{OUT} \geq 0.85V$		75		dB
		$f=1kHz, V_{ripple}=0.5V, I_{OUT}=30mA$ $V_{OUT}=0.8V$				
V_{OUT} Temperature coefficient (Note4)	$\Delta V_{OUT} / \Delta T$	$I_{OUT}=30mA$ $-40^{\circ}C \leq T_{OP} \leq 85^{\circ}C$		± 50		ppm/ $^{\circ}C$
Output current limit	I_{lim}		200	250		mA
Output short-circuit current	I_{short}	$V_{OUT}=0V$		30		mA
CE H threshold voltage	V_{CEH}		1.2		6.0	V
CE L threshold voltage	V_{CEL}				0.3	V
CE H threshold voltage	I_{CEH}		-0.1		0.1	μA
CE L threshold voltage	I_{CEL}		-0.1		0.1	μA
CL Discharge resistance	R_{disc}			780		Ω

Note4 : The item is guaranteed by design.

Electrical Characteristics 2 (Except where noted otherwise $V_{DD}=V_{OUT}(typ.)+1V$, $V_{CE}=V_{DD}$, $T_a=25^{\circ}C$)

Model No.	Item								
	Output voltage				Dropout voltage				
	V_{OUT} (V)				V_{io} (mV)				
	Measurement conditions	Min.	Typ.	Max.	Measurement conditions	Min.	Typ.	Max.	
MM3404A08	$I_{OUT}=10mA$	0.780	0.800	0.820	$I_{OUT}=100mA$ $V_{OUT}<1.5V$ (Note5)		500	850	
MM3404Z08		0.830	0.850	0.870					
MM3404A09		0.880	0.900	0.920			410	750	
MM3404Z09		0.930	0.950	0.970					
MM3404A10		0.980	1.000	1.020					
MM3404Z10		1.030	1.050	1.070			330	650	
MM3404A11		1.080	1.100	1.120					
MM3404Z11		1.130	1.150	1.170					
MM3404A12		1.180	1.200	1.220					
MM3404Z12		1.230	1.250	1.270			230	380	
MM3404A13		1.280	1.300	1.320					
MM3404Z13		1.330	1.350	1.370					
MM3404A14		1.380	1.400	1.420					
MM3404Z14		1.430	1.450	1.470			200	360	
MM3404A15		1.480	1.500	1.520		$I_{OUT}=100mA$ $V_{OUT}\geq 1.5V$ $V_{DD}=V_{OUT}(typ.)-0.2V$		180	290
MM3404Z15		1.530	1.550	1.570					
MM3404A16		1.580	1.600	1.620					
MM3404Z16		1.630	1.650	1.670			160	250	
MM3404A17		1.680	1.700	1.720					
MM3404Z17		1.730	1.750	1.770					
MM3404A18		1.780	1.800	1.820					
MM3404Z18		1.830	1.850	1.870			125	210	
MM3404A19		1.880	1.900	1.920					
MM3404Z19		1.930	1.950	1.970					
MM3404A20		1.980	2.000	2.020					
MM3404Z20		2.030	2.050	2.071					
MM3404A21		2.079	2.100	2.121					
MM3404Z21		2.129	2.150	2.172			115	195	
MM3404A22		2.178	2.200	2.222					
MM3404Z22		2.228	2.250	2.273					
MM3404A23		2.277	2.300	2.323					
MM3404Z23		2.327	2.350	2.374					
MM3404A24	2.376	2.400	2.424						
MM3404Z24	2.426	2.450	2.475						
MM3404A25	2.475	2.500	2.525						
MM3404Z25	2.525	2.550	2.576						
MM3404A26	2.574	2.600	2.626						
MM3404Z26	2.624	2.650	2.677						
MM3404A27	2.673	2.700	2.727						
MM3404Z27	2.723	2.750	2.778		95	170			
MM3404A28	2.772	2.800	2.828						
MM3404Z28	2.822	2.850	2.879						
MM3404A29	2.871	2.900	2.929						
MM3404Z29	2.921	2.950	2.980						

Note5 : Dropout voltage max. value in the input and it is confirmed that there is no output abnormal voltage impression the load 100mA in the model less than $V_{OUT}=1.45V$.

• Any products mentioned in this catalog are subject to any modification in their appearance and others for improvements without prior notification.
 • The details listed here are not a guarantee of the individual products at the time of ordering. When using the products, you will be asked to check their specifications.

Model No.	Item							
	Output voltage				Dropout voltage			
	V _{OUT} (V)				V _{IO} (mV)			
	Measurement conditions	Min.	Typ.	Max.	Measurement conditions	Min.	Typ.	Max.
MM3404A30	I _{OUT} =10mA	2.970	3.000	3.030	I _{OUT} =100mA V _{OUT} ≥1.5V V _{DD} =V _{OUT} (typ.)-0.2V		80	140
MM3404Z30		3.020	3.050	3.081				
MM3404A31		3.069	3.100	3.131				
MM3404Z31		3.119	3.150	3.182				
MM3404A32		3.168	3.200	3.232				
MM3404Z32		3.218	3.250	3.283				
MM3404A33		3.267	3.300	3.333				
MM3404Z33		3.317	3.350	3.384				
MM3404A34		3.366	3.400	3.434				
MM3404Z34		3.416	3.450	3.485				
MM3404A35		3.465	3.500	3.535				
MM3404Z35		3.515	3.550	3.586				
MM3404A36		3.564	3.600	3.636				
MM3404Z36		3.614	3.650	3.687				
MM3404A37		3.663	3.700	3.737				
MM3404Z37		3.713	3.750	3.788				
MM3404A38		3.762	3.800	3.838				
MM3404Z38		3.812	3.850	3.889				
MM3404A39		3.861	3.900	3.939				
MM3404Z39		3.911	3.950	3.990				
MM3404A40		3.960	4.000	4.040				
MM3404Z40		4.010	4.050	4.091				
MM3404A41		4.059	4.100	4.141				
MM3404Z41		4.109	4.150	4.192				
MM3404A42		4.158	4.200	4.242				
MM3404Z42		4.208	4.250	4.293				
MM3404A43		4.257	4.300	4.343				
MM3404Z43		4.307	4.350	4.394				
MM3404A44		4.356	4.400	4.444				
MM3404Z44		4.405	4.450	4.495				
MM3404A45		4.455	4.500	4.545				
MM3404Z45		4.504	4.550	4.595				
MM3404A46	4.554	4.600	4.646					
MM3404Z46	4.603	4.650	4.696					
MM3404A47	4.653	4.700	4.747					
MM3404Z47	4.702	4.750	4.797					
MM3404A48	4.752	4.800	4.848					
MM3404Z48	4.801	4.850	4.898					
MM3404A49	4.851	4.900	4.949					
MM3404Z49	4.900	4.950	4.999					
MM3404A50	4.950	5.000	5.050					

Note5 : Dropout voltage Max. value in the input and it is confirmed that there is no output abnormal voltage impression the load 100mA in the model less than V_{OUT}=1.45V.

Measuring Circuit

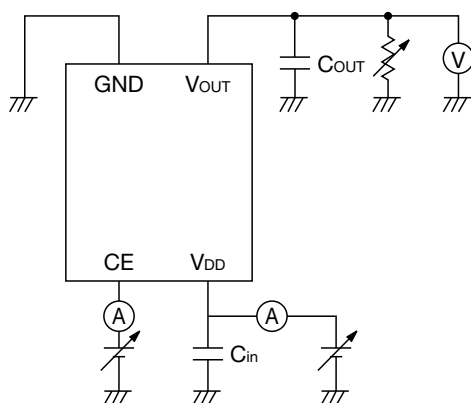

Application Circuit

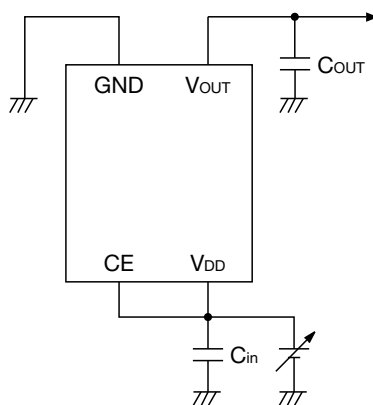

(reference example of external parts)

- Output capacitor Ceramic capacitor 1.0 μ F
- Input capacitor Ceramic capacitor 1.0 μ F

★ Temperature Characteristics : B

· Note

1. The output capacitor is required between output and GND to prevent oscillation.
2. The ESR of capacitor must be defined in ESR stability area.
It is possible to use a ceramic capacitor without ESR resistance for output.
The ceramic capacitor must be used more than 1.0 μ F and B temperature characteristics.
3. The wire of Vcc and GND is required to print full ground plane for noise and stability.
4. The input capacitor must be connected a distance of less than 1cm from input pin.
5. In case the output voltage is above the input voltage, the overcurrent flow by internal parastic diode from output to input.

Characteristics (Vo=0.8V) (Except where noted otherwise $V_{DD}=V_{OUT}(\text{typ.}) + 1V$, $V_{CE}=V_{DD}$, $T_a=25^\circ\text{C}$)

Output - Input voltage

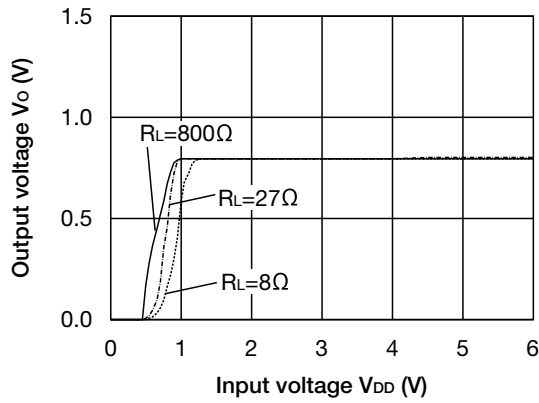

Input current - Input voltage

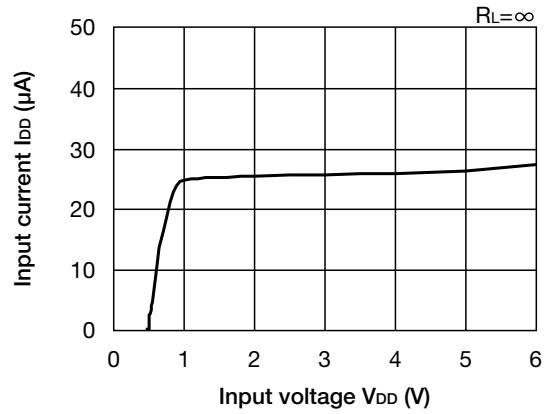

Load regulation

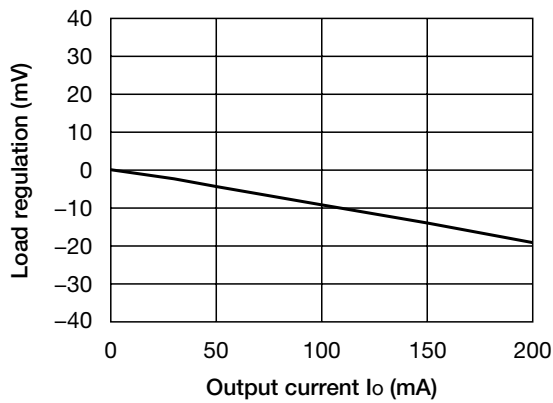

Line regulation

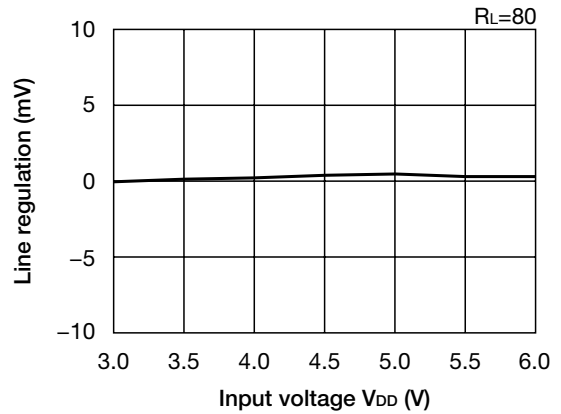

V_{OUT} temperature coefficient

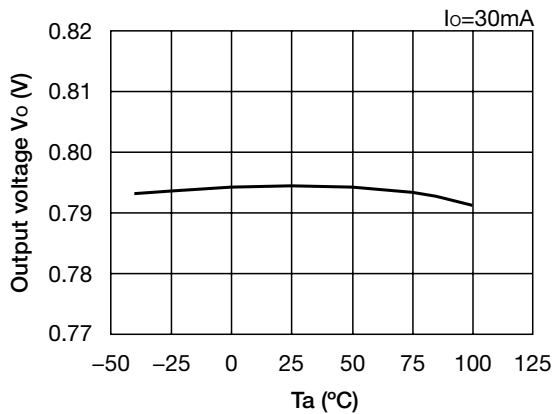

Ripple Rejection

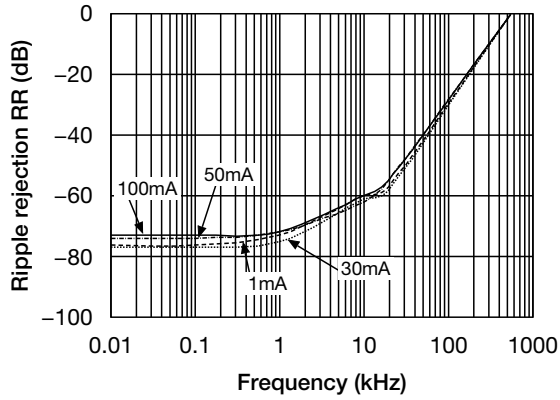

ESR stability area

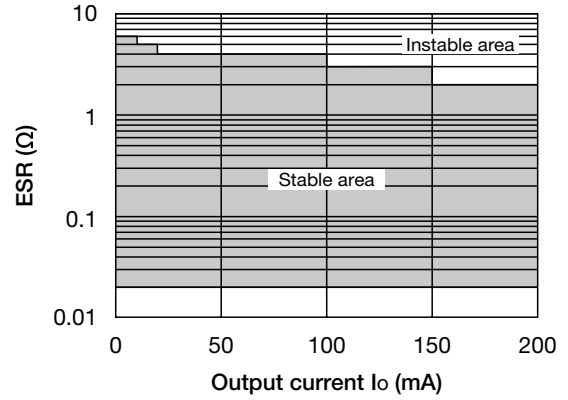

Current Limit

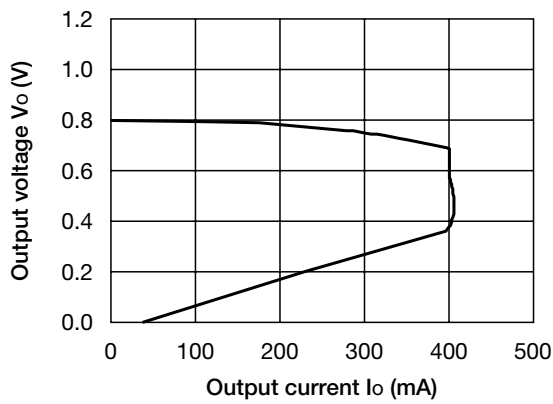

■ Load transient response ($V_{DD}=V_o+1V$, $V_{CE}=V_{DD}$, $C_{in}=C_o=1\mu F$)

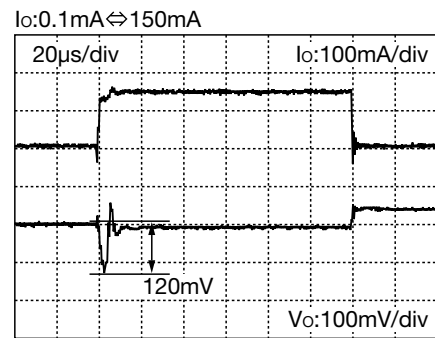
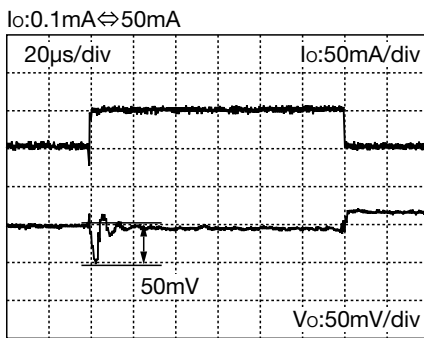
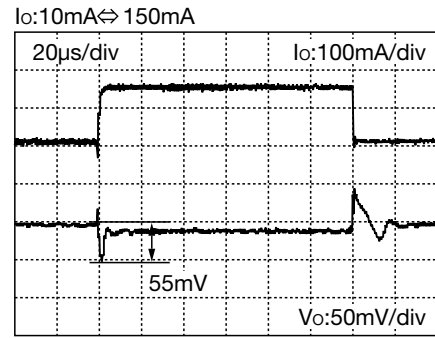
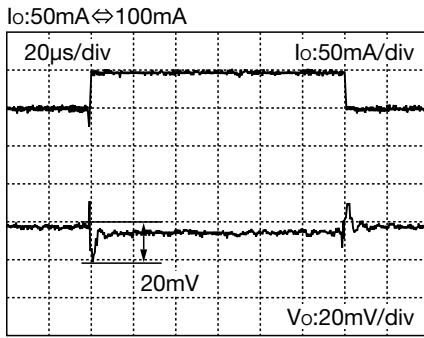

■ Input rise characteristics
($V_{DD}=0V \rightarrow 1.8V$, $V_{CE}=V_{DD}$, $I_o=30mA$)

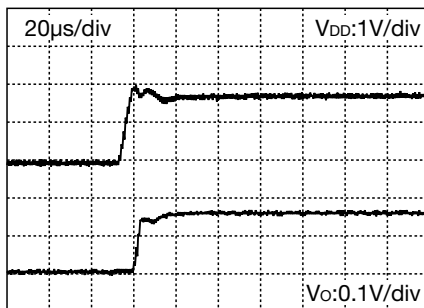

■ CE rise characteristics
($V_{DD}=1.8V$, $V_{CE}=0V \rightarrow V_{DD}$, $I_o=30mA$)

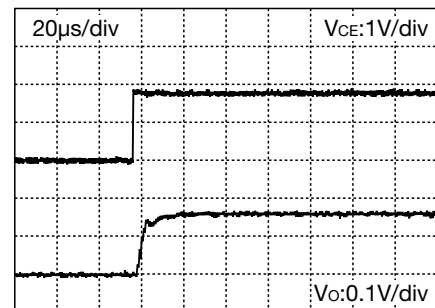

Characteristics (Vo=3.0V) (Except where noted otherwise VDD=VOUT (typ.) +1V, VCE=VDD, Ta=25°C)

Output - Input voltage

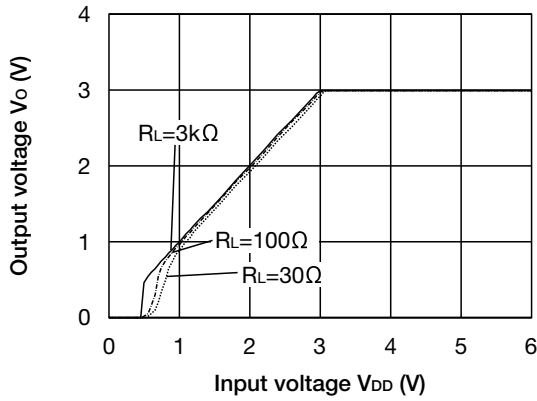

Input current - Input voltage

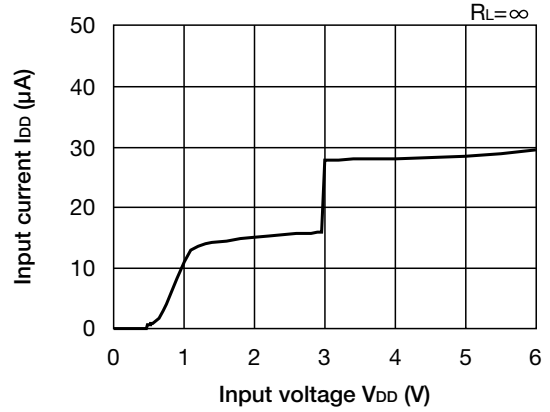

Load regulation

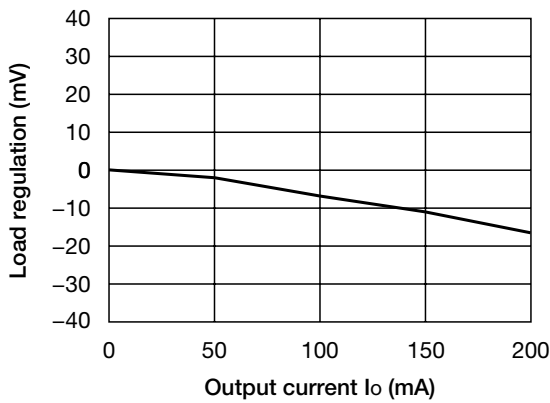

Line regulation

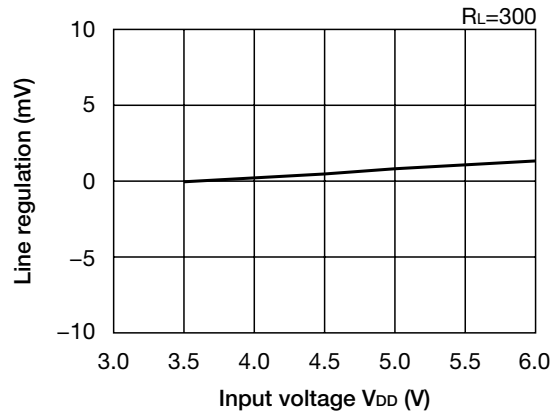

Dropout voltage

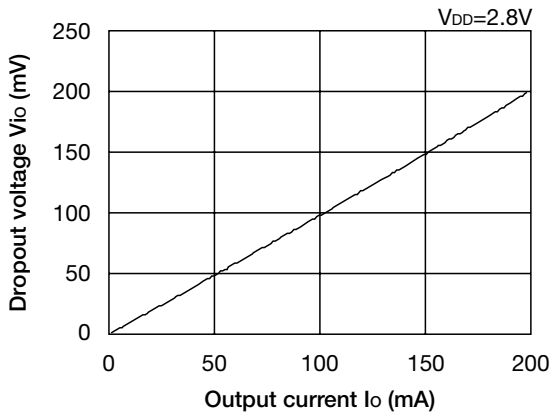

VOUT temperature coefficient

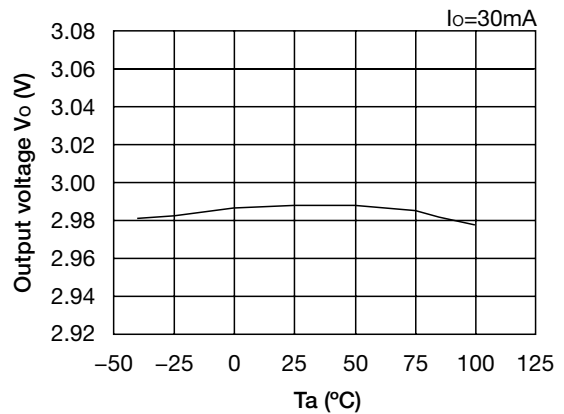

Ripple Rejection

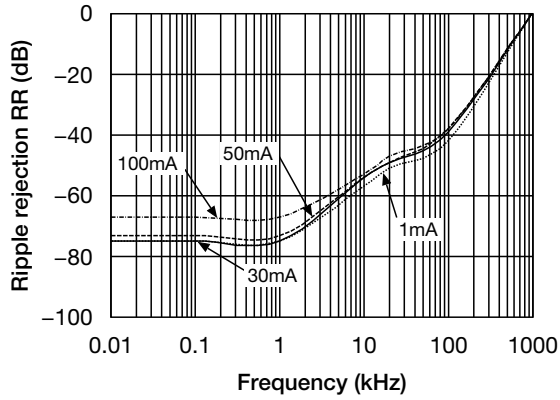

ESR stability area

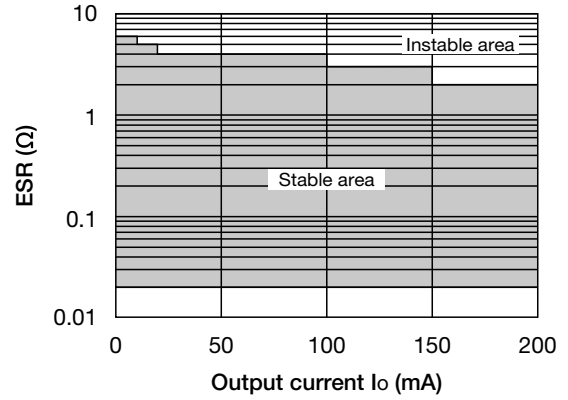

Current Limit

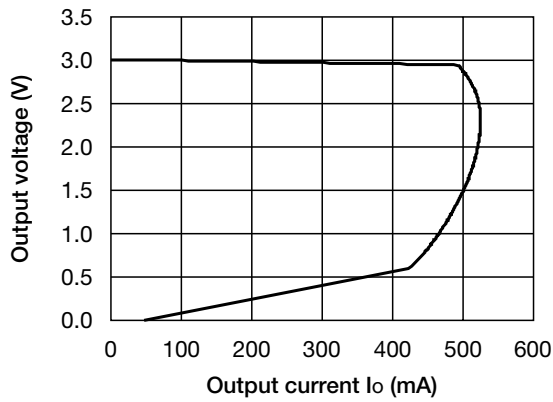

■ Load transient response ($V_{DD}=V_o+1V$, $V_{CE}=V_{DD}$, $C_{in}=C_o=1\mu F$)

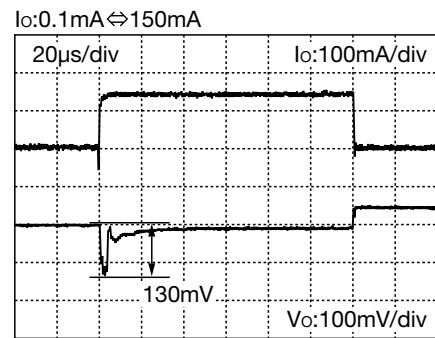
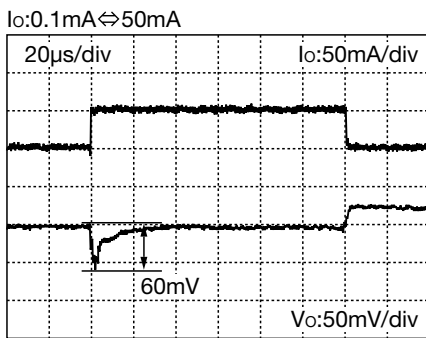
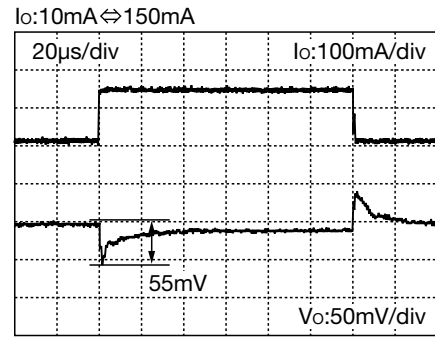
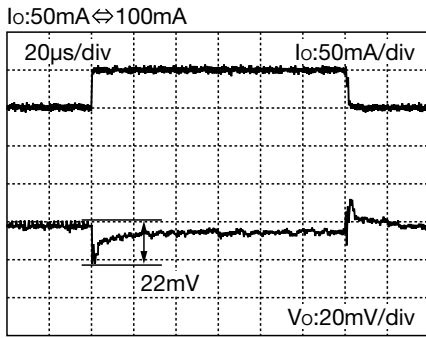

■ Input rise characteristics
($V_{DD}=0V \rightarrow 4.0V$, $V_{CE}=V_{DD}$, $I_o=30mA$)

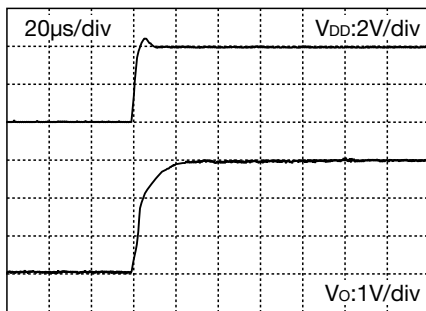

■ CE rise characteristics
($V_{DD}=4V$, $V_{CE}=0V \rightarrow V_{DD}$, $I_o=30mA$)

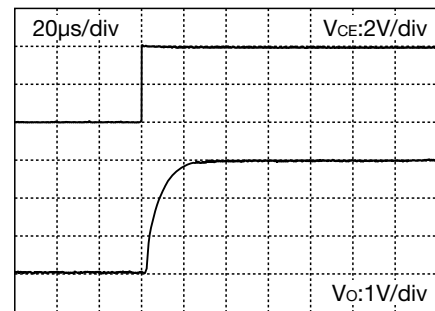

Characteristics (Vo=5.0V) (Except where noted otherwise $V_{DD}=V_{OUT}(\text{typ.}) + 1V$, $V_{CE}=V_{DD}$, $T_a=25^\circ\text{C}$)

Output - Input voltage

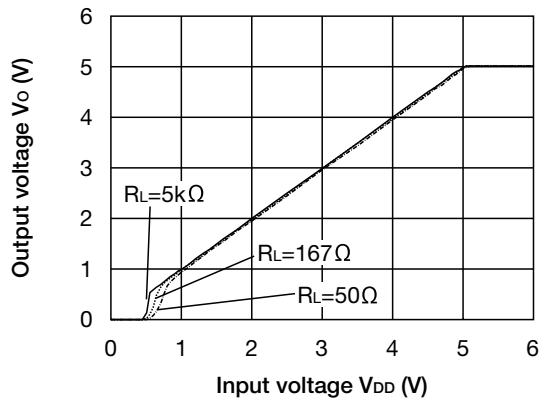

Input current - Input voltage

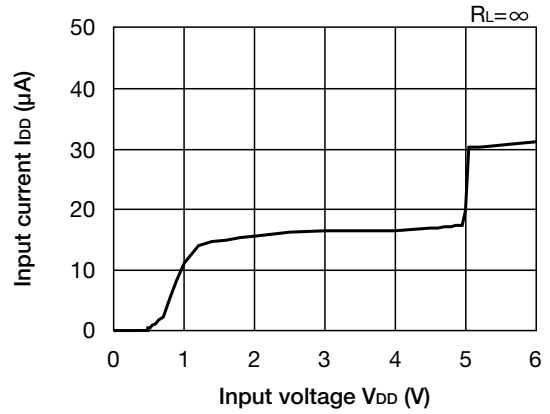

Load regulation

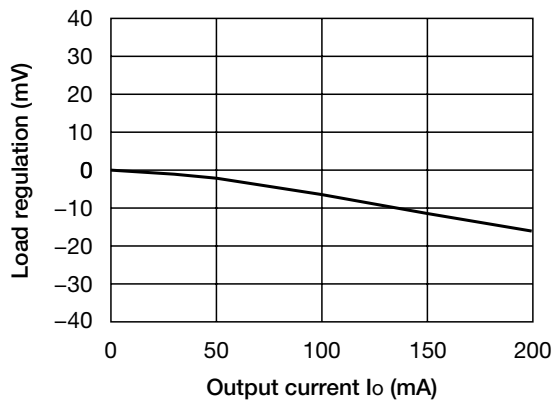

Line regulation

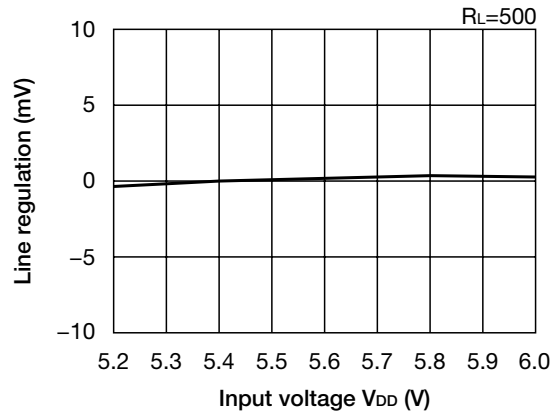

Dropout voltage

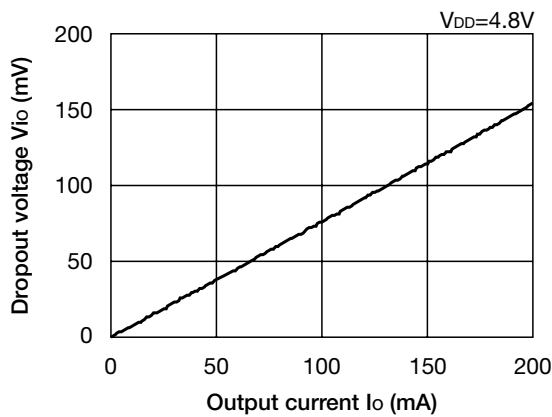

VOUT temperature coefficient

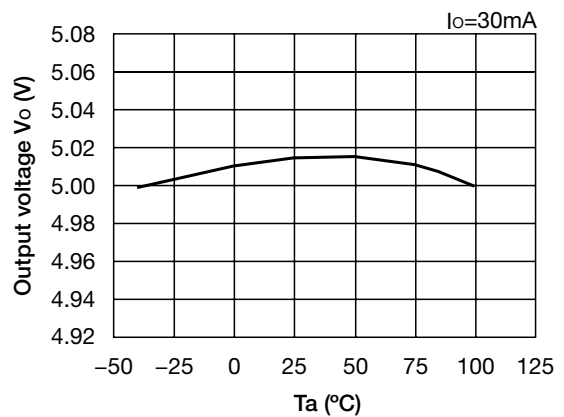

Ripple Rejection

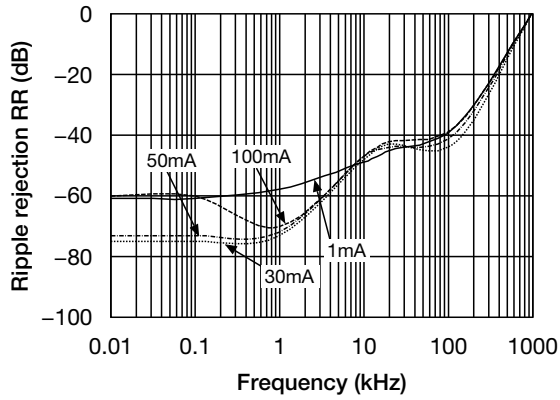

ESR stability area

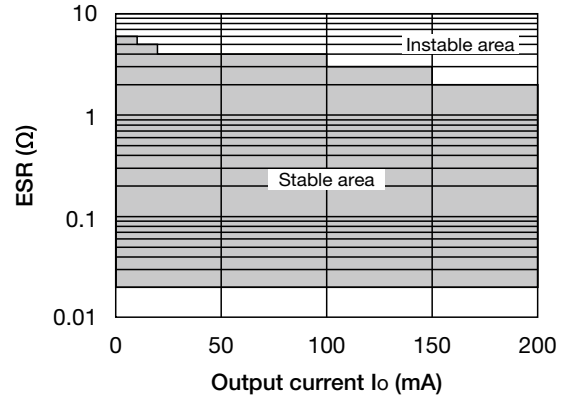

Current Limit

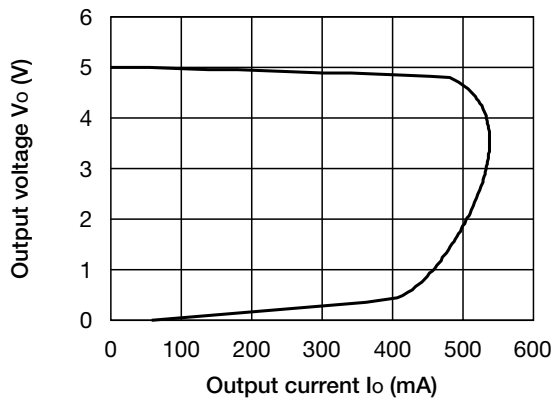

■ Load transient response ($V_{DD}=V_o+1V$, $V_{CE}=V_{DD}$, $C_{in}=C_o=1\mu F$)

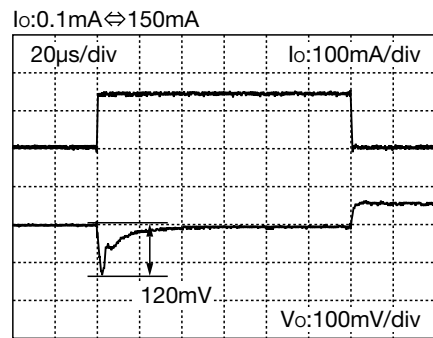
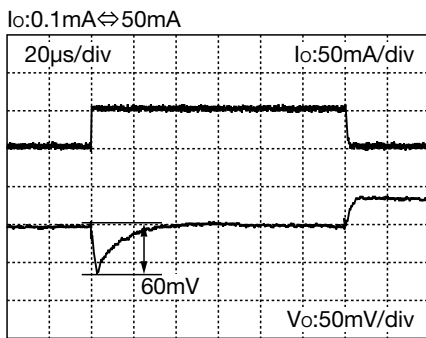
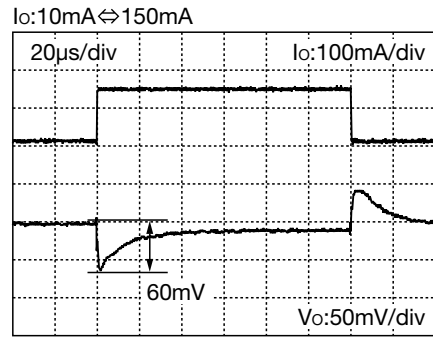
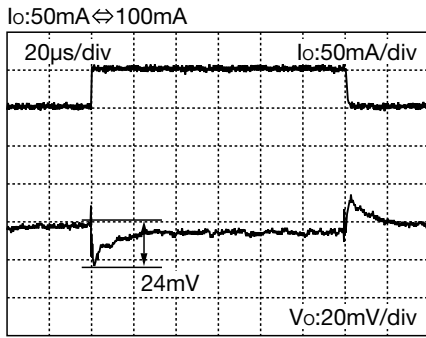

■ Input rise characteristics ($V_{DD}=0V \rightarrow 6.0V$, $V_{CE}=V_{DD}$, $I_o=30mA$)

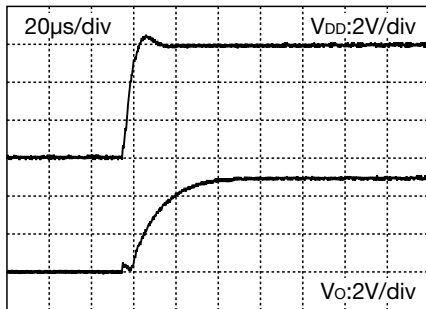

■ CE rise characteristics ($V_{DD}=6.0V$, $V_{CE}=0V \rightarrow V_{DD}$, $I_o=30mA$)

