

CMOS Regulator Monolithic IC MM327□ Series

Outline

This IC is a regulator IC that provides ultra-low current consumption (0.8μA), and low input voltage ($V_{O+0.3\sim 6.0V}$), and has been developed using the CMOS process. Moreover, in addition to characteristics such as ultra-low current consumption and low dropout voltage, it supports long lifetime of batteries with a chip enable function.

The mount area is set to 1.10x1.40mm using a surface mount type leadless 4pin package, which realizes microminiaturization.

Features

1. Input Voltage Range	$V_{O+0.3\sim 6.0V}$
2. Output Voltage Range	0.8~5.0V
3. Output Voltage accuracy	$V_{OUT}\pm 2\%$
4. Maximum Output Current	150mA
5. Supply Current	0.8μA typ. ($I_{OUT}=0mA$) 0.1μA typ. (OFF)
6. Output Capacitor	0.1μF
7. Dropout Voltage	30mV Typ ($I_{OUT}=10mA$)
8. Chip enable function	High: ON, Low: OFF
9. Output Short-Circuit Current	60mA

Package

SOT-25A
SC-82ABA
SC-82ABB
SSON-4

Applications

1. Cellular phone, Smart phone
2. Portable game device
3. Digital camera
4. Note PC
5. Tablet

Pin Assignment

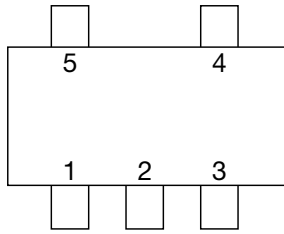

SOT-25A
(TOP VIEW)

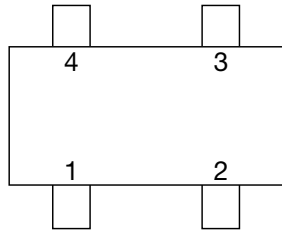

SC-82ABA
SC-82ABB
(TOP VIEW)

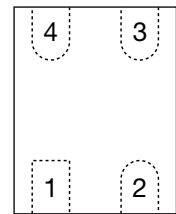

SSON-4
(TOP VIEW)

1	V _{DD}
2	GND
3	CE
4	NC
5	V _{OUT}

1	CE
2	GND
3	V _{OUT}
4	V _{DD}

1	CE
2	V _{DD}
3	V _{OUT}
4	GND

Block Diagram

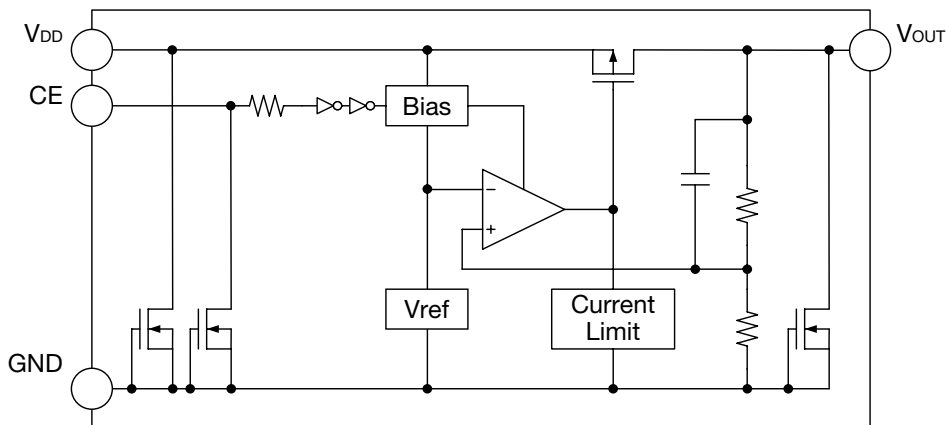

Pin Description

Pin No.			Pin name	Functions						
SOT-25A	SC-82ABA SC-82ABB	SSON-4								
1	4	2	V _{DD}	Voltage-supply pin						
2	2	4	GND	GND pin						
3	1	1	CE	ON/OFF-control pin <table border="1" style="margin-left: 20px;"> <tr> <td>CE</td> <td>V_{OUT}</td> </tr> <tr> <td>L</td> <td>OFF</td> </tr> <tr> <td>H</td> <td>ON</td> </tr> </table> Connect CE pin with V _{DD} pin, when it is not used.	CE	V _{OUT}	L	OFF	H	ON
CE	V _{OUT}									
L	OFF									
H	ON									
4			NC							
5	3	3	V _{OUT}	Output pin						

• Any products mentioned in this catalog are subject to any modification in their appearance and others for improvements without prior notification.
 • The details listed here are not a guarantee of the individual products at the time of ordering. When using the products, you will be asked to check their specifications.

Absolute Maximum Ratings (Ta=25°C)

Item	Symbol	Ratings	Unit
Storage Temperature	T _{STG}	-55~+150	°C
Supply Voltage	V _{DD}	6.5	V
CE Input Voltage	V _{CE}	-0.3~+6.5	V
Output Voltage	V _{OUT}	-0.3~V _{DD} +0.3	V
Output Current	I _{OUT}	200	mA
Allowable loss (Note1)	P _d	350 (SOT-25A) 150 (SC-82ABA) 150 (SC-82ABB) 330 (SSON-4)	mW

Note1 : With PC Board of glass epoxy
 SOT-25A : 60×40×1.6^t mm
 SC-82ABA, SC-82ABB : 100×100×1.6^t mm
 SSON-4 : 110×40×0.8^t mm

Recommended Operating Conditions (Ta=25°C)

Item	Symbol	Ratings	Unit
Operating Ambient Temperature	T _{JDDOP}	-40~+85	°C
Operating Voltage	V _{DDOP}	V _O +0.3~6.0	V
Output Current	I _{OUT}	0~150	mA

Electrical Characteristics (Unless otherwise noted, Ta=25°C, V_{DD}=V_{OUT} (typ.) +1V, V_{CE}=V_{DD})

Item	Symbol	Measurement conditions	Min.	Typ.	Max.	Unit
Input Current (OFF)	I _{DDoff}	V _{CE} =0V		0.1		μA
No-Load Input Current	I _{DD}	I _{OUT} =0mA		0.8	2.0	μA
Output Voltage (Note3)	V _{OUT}	I _{OUT} =1mA	×0.98		×1.02	V
Line Regulation	V _{LINE}	I _{OUT} =1mA V _{DD} =V _O +0.5V→6V		0.05	0.20	%/V
Load Regulation	V _{LODE}	1mA ≤ I _{OUT} ≤ 150mA		30	90	mV
Dropout Voltage (Note2)	V _{io}	Please refer to another page		0.03	0.05	V
Output Short-Circuit Current (Note2)	I _{lim}	V _{OUT} =0V		60		mA
V _{OUT} Temperature Coefficient	ΔV _{OUT} /ΔV _{OP}	I _{OUT} =30mA, -40°C ≤ T _{OP} ≤ +85°C		±100		ppm/°C
CE High Threshold Voltage	V _{CEH}		1.0		6.0	V
CE Low Threshold Voltage	V _{CEL}		0		0.3	V

Note2 : The parameter is guaranteed by design.

Note3 : The Output Voltage accuracy is ±30mV in the model less than V_{OUT} 1.4V.

Electrical Characteristics 2 (Unless otherwise noted, Ta=25°C, VDD=VOUT (typ.) +1V, VCE=VDD)

Product Name	Parameter							
	Output Voltage (Note4)				Dropout Voltage			
	VOUT (V)				VDIF (V)			
	Test Conditions	Min.	Typ.	Max.	Test Conditions	Min.	Typ.	Max.
MM3270J	IOUT=1mA	0.770	0.8	0.830	(Note5)			
MM3270K		0.870	0.9	0.930				
MM3271A		0.970	1.0	1.030				
MM3271B		1.070	1.1	1.130				
MM3271C		1.170	1.2	1.230				
MM3271D		1.270	1.3	1.330				
MM3271E		1.370	1.4	1.430				
MM3271F		1.470	1.5	1.530	IOUT=10mA 1.5V ≤ VOUT ≤ 1.9V	0.12	0.15	
MM3271G		1.568	1.6	1.632				
MM3271H		1.666	1.7	1.734				
MM3271J		1.764	1.8	1.836				
MM3271K		1.862	1.9	1.938				
MM3272A		1.960	2.0	2.040	IOUT=10mA 2.0V ≤ VOUT ≤ 2.4V	0.08	0.12	
MM3272B		2.058	2.1	2.142				
MM3272C		2.156	2.2	2.244				
MM3272D		2.254	2.3	2.346				
MM3272E		2.352	2.4	2.448				
MM3272F		2.450	2.5	2.550	IOUT=10mA 2.5V ≤ VOUT ≤ 2.9V	0.06	0.08	
MM3272G		2.548	2.6	2.652				
MM3272H		2.646	2.7	2.754				
MM3272J		2.744	2.8	2.856				
MM3272K		2.842	2.9	2.958				
MM3273A		2.940	3.0	3.060	IOUT=10mA 3.0V ≤ VOUT ≤ 3.2V	0.05	0.07	
MM3273B		3.038	3.1	3.162				
MM3273C		3.136	3.2	3.264				
MM3273D		3.234	3.3	3.366	IOUT=10mA 3.3V ≤ VOUT ≤ 5.0V	0.03	0.05	
MM3273E		3.332	3.4	3.468				
MM3273F		3.430	3.5	3.570				
MM3273G		3.528	3.6	3.672				
MM3273H		3.626	3.7	3.774				
MM3273J	3.724	3.8	3.876					
MM3273K	3.822	3.9	3.978					
MM3274A	3.920	4.0	4.080					
MM3274B	4.018	4.1	4.182					
MM3274C	4.116	4.2	4.284					
MM3274D	4.214	4.3	4.386					
MM3274E	4.312	4.4	4.488					
MM3274F	4.410	4.5	4.590					
MM3274G	4.508	4.6	4.692					
MM3274H	4.606	4.7	4.794					
MM3274J	4.704	4.8	4.896					
MM3274K	4.802	4.9	4.998					
MM3275A	4.900	5.0	5.100					

Note4 : The Output Voltage accuracy is ±30mV in the model less than VOUT 1.4V.

Note5 : The parameter is guaranteed in the model less than VOUT 1.4V.

• Any products mentioned in this catalog are subject to any modification in their appearance and others for improvements without prior notification.
 • The details listed here are not a guarantee of the individual products at the time of ordering. When using the products, you will be asked to check their specifications.

Measuring Circuit

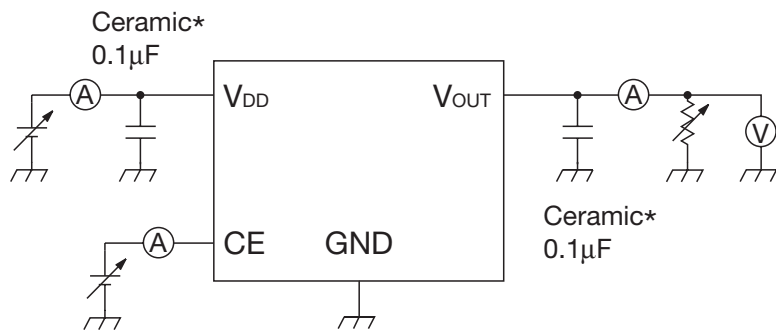

Typical Application Circuit

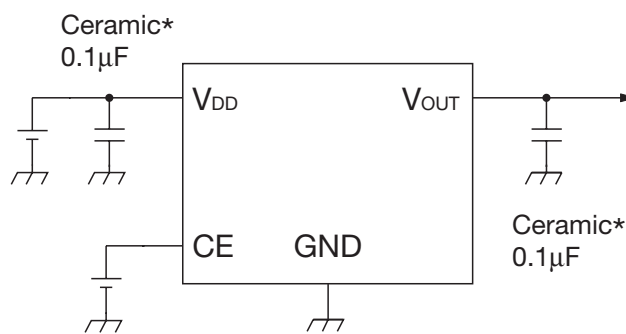

Note

1. The output capacitor is required between output and GND to prevent oscillation.
2. The ESR of capacitor must be defined in ESR stability area.
It is possible to use a ceramic capacitor without ESR resistance for output.
The ceramic capacitor must be used more than 0.1µF and B temperature characteristics.
3. The wire of V_{CC} and GND is required to print full ground plane for noise and stability.
4. The input capacitor must be connected a distance of less than 1cm from input pin.
5. In case the output voltage is above the input voltage, the overcurrent flow by internal parasitic diode from output to input.