

# CMOS Regulator Monolithic IC MM324□□ Series

## Outline

This is a regulator IC that high ripple eliminant rate (77dB), and has been developed using the CMOS process. Moreover, in addition to characteristics such as low current consumption and low dropout voltage, it supports long lifetime of batteries with a chip enable function.

The mount area is set to 1.10x1.40mm using a surface mount type leadless 4pin package, which realizes microminiaturization.

## Features

- |                            |                  |
|----------------------------|------------------|
| 1. Input Voltage Range     | 2~6V             |
| 2. Output Voltage Range    | 1.5~5.0V         |
| 3. Output Voltage accuracy | ±1%              |
| 4. Maximum Output Current  | 150mA            |
| 5. Supply Current          | 10µA typ.        |
| 6. Dropout Voltage         | 0.06mV max.      |
| 7. Output ON/OFF function  | High:ON, Low:OFF |

## Package

SSON-4A  
SOT-25A

## Applications

1. Cellular Phone
2. Portable Game Device
3. Portable Information Terminal
4. Digital Cameras
5. Note PCs

## Pin Assignment

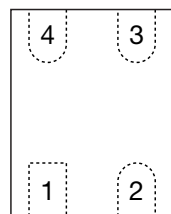

SSON-4A  
(TOP VIEW)

1	CE
2	V <sub>DD</sub>
3	V <sub>OUT</sub>
4	GND

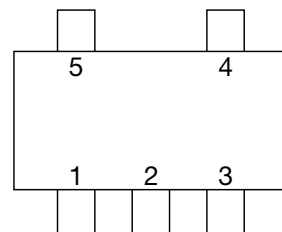

SOT-25A  
(TOP VIEW)

1	V <sub>DD</sub>
2	GND
3	CE
4	NC
5	V <sub>OUT</sub>

## Block Diagram

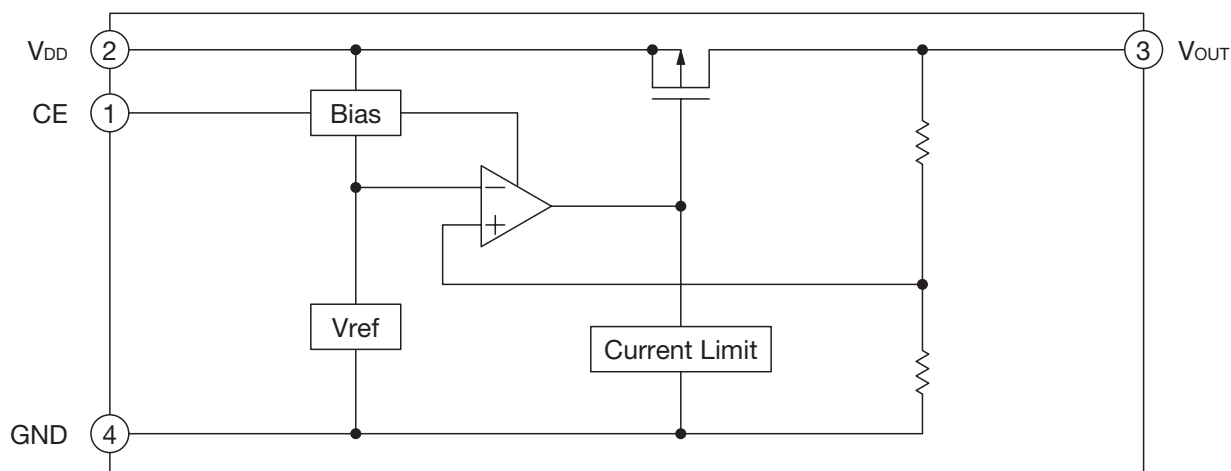

## Pin Description

Pin No.	Pin name	Functions	
1	CE	ON/OFF-control pin	
		CE	Output
		L	OFF
		H	ON
		Connect CE pin with V <sub>DD</sub> pin, when it is not used.	
2	V <sub>DD</sub>	Voltage-supply pin	
3	V <sub>OUT</sub>	Output pin	
4	GND	GND pin	

### Absolute Maximum Ratings (Ta=25°C)

Item	Symbol	Ratings	Unit
Storage Temperature	T <sub>STG</sub>	-55~+150	°C
Supply Voltage	V <sub>DD</sub>	-0.3~+7.0	V
CE Input Voltage	V <sub>CE</sub>	-0.3~V <sub>DD</sub> +0.3	V
Output Voltage	V <sub>OUT</sub>	-0.3~V <sub>DD</sub> +0.3	V
Output Current	I <sub>o</sub> max.	200	mA
Allowable loss	P <sub>d</sub>	330 *	mW

Note1 : \*With PC Board of glass epoxy  
110×40×0.8<sup>t</sup> mm

### Recommended Operating Conditions (Ta=25°C)

Item	Symbol	Ratings	Unit
Operating Ambient Temperature	T <sub>JOP</sub>	-40~+85	°C
Operating Voltage	V <sub>OP</sub>	2.0~6.0	V
Output Current	I <sub>o</sub>	0~150	mA

### Electrical Characteristics (Unless otherwise noted, Ta=25°C, V<sub>DD</sub>=V<sub>OUT</sub> (typ.) +1V, V<sub>CE</sub>=V<sub>DD</sub>)

Item	Symbol	Measurement conditions	Min.	Typ.	Max.	Unit
Input Current (OFF)	I <sub>DDoff</sub>	V <sub>CE</sub> =0V		0.01	1.0	μA
No-Load Input Current	I <sub>DD</sub>	I <sub>OUT</sub> =0mA		10	18	μA
Output Voltage	V <sub>OUT</sub>	I <sub>OUT</sub> =30mA	×0.99		×1.01	V
Line Regulation	V <sub>LINE</sub>	V <sub>DD</sub> =V <sub>o</sub> (typ.) +0.5~6V, I <sub>OUT</sub> =30mA (V <sub>OUT</sub> ≤ 1.6V, V <sub>DD</sub> =2.2~6V)		0.01	0.2	%/V
Load Regulation	V <sub>LODE</sub>	1mA ≤ I <sub>OUT</sub> ≤ 80mA		15	50	mV
Dropout Voltage	V <sub>io</sub>	Please refer to another page				V
Ripple Rejection 1 *	RR1	f=1kHz, V <sub>ripple</sub> =0.5V, I <sub>OUT</sub> =50mA 1.5V ≤ V <sub>OUT</sub> ≤ 5.0V		77		dB
Ripple Rejection 2 *	RR2	f=10kHz, V <sub>ripple</sub> =0.5V, I <sub>OUT</sub> =50mA 1.5V ≤ V <sub>OUT</sub> ≤ 5.0V		65		dB
V <sub>OUT</sub> Temperature Coefficient	ΔV <sub>OUT</sub> /ΔT	I <sub>OUT</sub> =30mA, -40°C ≤ T <sub>OP</sub> ≤ 85°C		±100		ppm/°C
Output Short-Circuit Current	I <sub>lim</sub>	V <sub>OUT</sub> =0V		50		mA
CE High Threshold Voltage	V <sub>CEH</sub>		1.5			V
CE Low Threshold Voltage	V <sub>CEL</sub>				0.25	V
CE High Threshold Current	I <sub>CEH</sub>		-0.1		0.1	μA
CE Low Threshold Current	I <sub>CEL</sub>		-0.1		0.1	μA

Note1 : \*The parameter is guaranteed by design.

**Electrical Characteristics 2** (Unless otherwise noted,  $T_a=25^\circ\text{C}$ ,  $V_{DD}=V_{OUT}$  (typ.) +1V,  $V_{CE}=V_{DD}$ )

Product Name	Parameter							
	Output Voltage				Dropout Voltage			
	$V_{OUT}$ (V)				$V_{DIF}$ (V)			
	Test Conditions	Min.	Typ.	Max.	Test Conditions	Min.	Typ.	Max.
MM3241F	$1\text{mA} \leq I_{OUT} \leq 30\text{mA}$	1.485	1.500	1.515	$I_{OUT}=30\text{mA}$ $1.5\text{V} \leq V_{OUT} \leq 1.9\text{V}$		0.1	0.15
MM3241G		1.584	1.600	1.616				
MM3241H		1.683	1.700	1.717				
MM3241J		1.782	1.800	1.818				
MM3241K		1.881	1.900	1.919				
MM3242A		1.980	2.000	2.020	$2.0\text{V} \leq V_{OUT} \leq 2.4\text{V}$		0.08	0.12
MM3242B		2.079	2.100	2.121				
MM3242C		2.178	2.200	2.222				
MM3242D		2.277	2.300	2.323				
MM3242E		2.376	2.400	2.424				
MM3242F		2.475	2.500	2.525	$2.5\text{V} \leq V_{OUT} \leq 2.9\text{V}$		0.06	0.08
MM3242G		2.574	2.600	2.626				
MM3242H		2.673	2.700	2.727				
MM3242J		2.772	2.800	2.828				
MM3242K		2.871	2.900	2.929				
MM3243A		2.970	3.000	3.030	$3.0\text{V} \leq V_{OUT} \leq 3.2\text{V}$		0.05	0.07
MM3243B		3.069	3.100	3.131				
MM3243C		3.168	3.200	3.232				
MM3243D		3.267	3.300	3.333	$3.3\text{V} \leq V_{OUT} \leq 5.0\text{V}$		0.04	0.06
MM3243E		3.366	3.400	3.434				
MM3243F		3.465	3.500	3.535				
MM3243G		3.564	3.600	3.636				
MM3243H		3.663	3.700	3.737				
MM3243J		3.762	3.800	3.838				
MM3243K		3.861	3.900	3.939				
MM3244A		3.960	4.000	4.040				
MM3244B		4.059	4.100	4.141				
MM3244C		4.158	4.200	4.242				
MM3244D		4.257	4.300	4.343				
MM3244E		4.356	4.400	4.444				
MM3244F		4.455	4.500	4.545				
MM3244G		4.554	4.600	4.646				
MM3244H		4.653	4.700	4.747				
MM3244J	4.752	4.800	4.848					
MM3244K	4.851	4.900	4.949					
MM3245A	4.950	5.000	5.050					

• Any products mentioned in this catalog are subject to any modification in their appearance and others for improvements without prior notification.  
 • The details listed here are not a guarantee of the individual products at the time of ordering. When using the products, you will be asked to check their specifications.

Product Name	Parameter							
	Output Voltage				Dropout Voltage			
	V <sub>OUT</sub> (V)				V <sub>DIF</sub> (V)			
	Test Conditions	Min.	Typ.	Max.	Test Conditions	Min.	Typ.	Max.
MM3241F	I <sub>OUT</sub> =30mA	1.485	1.500	1.515	I <sub>OUT</sub> =100mA 1.5V ≤ V <sub>OUT</sub> ≤ 1.9V		0.6	0.8
MM3241G		1.584	1.600	1.616				
MM3241H		1.683	1.700	1.717				
MM3241J		1.782	1.800	1.818				
MM3241K		1.881	1.900	1.919				
MM3242A		1.980	2.000	2.020	2.0V ≤ V <sub>OUT</sub> ≤ 2.4V		0.24	0.31
MM3242B		2.079	2.100	2.121				
MM3242C		2.178	2.200	2.222				
MM3242D		2.277	2.300	2.323				
MM3242E		2.376	2.400	2.424				
MM3242F		2.475	2.500	2.525	2.5V ≤ V <sub>OUT</sub> ≤ 2.9V		0.16	0.23
MM3242G		2.574	2.600	2.626				
MM3242H		2.673	2.700	2.727				
MM3242J		2.772	2.800	2.828				
MM3242K		2.871	2.900	2.929				
MM3243A		2.970	3.000	3.030	3.0V ≤ V <sub>OUT</sub> ≤ 3.2V		0.14	0.21
MM3243B		3.069	3.100	3.131				
MM3243C		3.168	3.200	3.232				
MM3243D		3.267	3.300	3.333	3.3V ≤ V <sub>OUT</sub> ≤ 5.0V		0.13	0.19
MM3243E		3.366	3.400	3.434				
MM3243F		3.465	3.500	3.535				
MM3243G		3.564	3.600	3.636				
MM3243H		3.663	3.700	3.737				
MM3243J		3.762	3.800	3.838				
MM3243K		3.861	3.900	3.939				
MM3244A		3.960	4.000	4.040				
MM3244B		4.059	4.100	4.141				
MM3244C		4.158	4.200	4.242				
MM3244D		4.257	4.300	4.343				
MM3244E		4.356	4.400	4.444				
MM3244F		4.455	4.500	4.545				
MM3244G		4.554	4.600	4.646				
MM3244H		4.653	4.700	4.747				
MM3244J		4.752	4.800	4.848				
MM3244K	4.851	4.900	4.949					
MM3245A	4.950	5.000	5.050					

• Any products mentioned in this catalog are subject to any modification in their appearance and others for improvements without prior notification.  
 • The details listed here are not a guarantee of the individual products at the time of ordering. When using the products, you will be asked to check their specifications.

Measuring Circuit

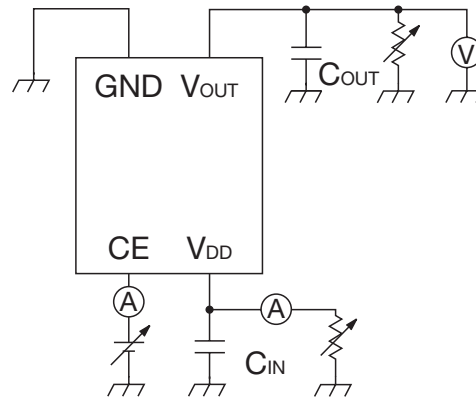

Typical Application Circuit

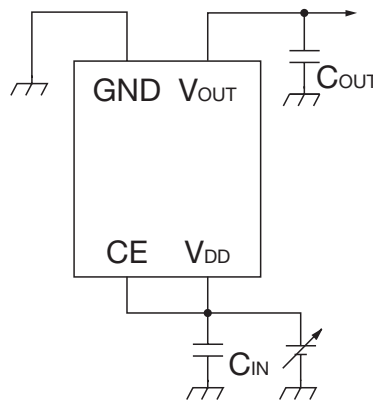

★Temperature Characteristics: B

(reference example of external parts)

- Output Capacitor                      Ceramic Capacitor 0.1μF
- Input Capacitor                        Ceramic Capacitor 0.1μF

Note

1. The output capacitor is required between output and GND to prevent oscillation.
2. The ESR of capacitor must be defined in ESR stability area.  
It is possible to use a ceramic capacitor without ESR resistance for output.  
The ceramic capacitor must be used more than 0.1μF and B temperature characteristics.
3. The wire of V<sub>CC</sub> and GND is required to print full ground plane for noise and stability.
4. The input capacitor must be connected a distance of less than 1cm from input pin.
5. In case the output voltage is above the input voltage, the overcurrent flow by internal parasitic diode from output to input.

**Characteristics** (Unless otherwise noted,  $T_a=25^\circ\text{C}$ ,  $V_{DD}=V_{OUT}(\text{typ.})+1\text{V}$ ,  $V_{CE}=V_{DD}$ )

**Output - Input Voltage**

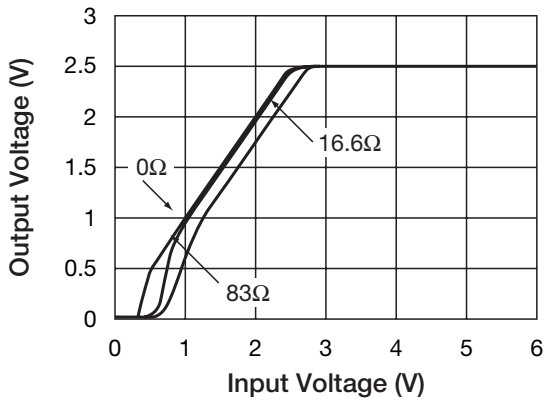

**Input Voltage - Input Current**

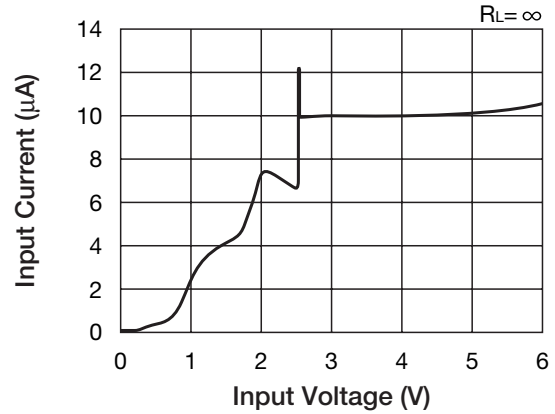

**Load Regulation**

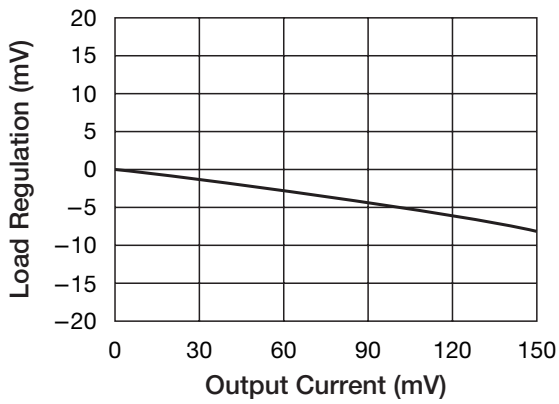

**Line Regulation**

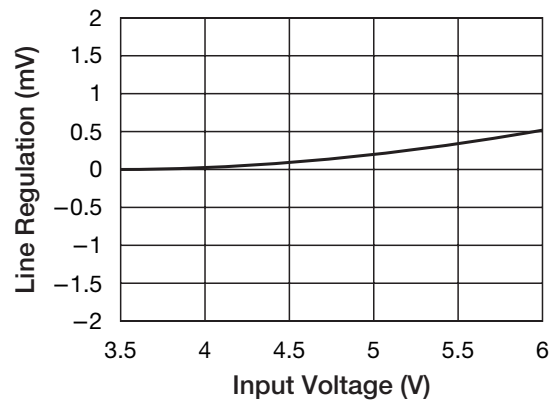

**Dropout Voltage - Output Current**

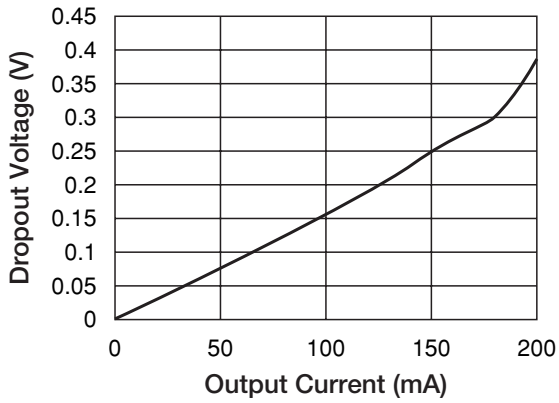

**Current Limit**

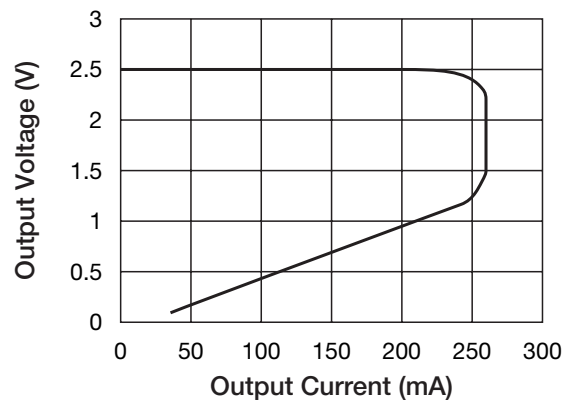

• Any products mentioned in this catalog are subject to any modification in their appearance and others for improvements without prior notification.  
 • The details listed here are not a guarantee of the individual products at the time of ordering. When using the products, you will be asked to check their specifications.

■ ESR Stability area

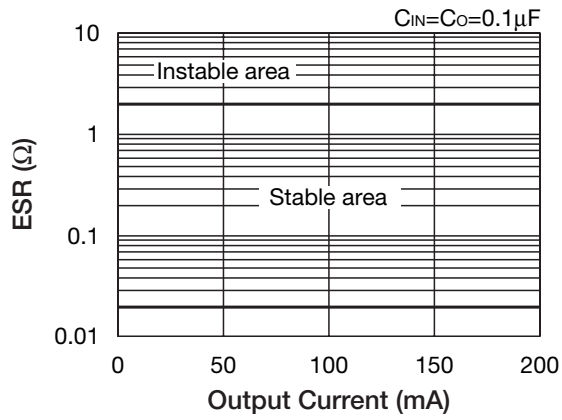

■ Ripple Rejection

