

## 23-26GHz Reflective SP4T Switch

### GaAs Monolithic Microwave IC in SMD leadless package

#### Description

The CHS2411-QDG (CHS2412-QDG, see Note) is a monolithic reflective SP4T switch in K-Band. Positive supply voltage only is required.

The circuit is manufactured with a standard pHEMT process, 0.25 $\mu$ m gate length, via holes through the substrate, air bridges and electron beam gate lithography.

The chip is delivered in a 24 Leads RoHS compliant QFN 4x4 package.

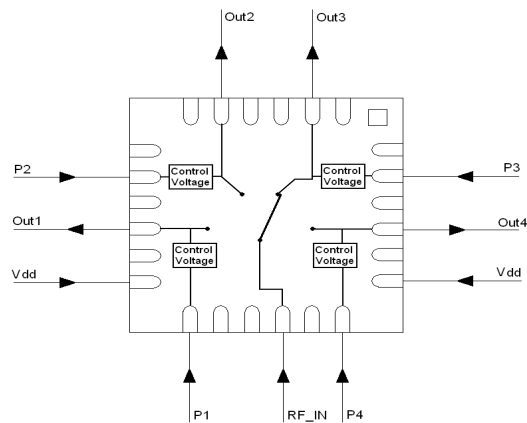

Functional Block Diagram

#### Main Features

- Low insertion loss: 2.9dB Typ.
- High isolation: 35dB Typ.
- Fast switching time
- Low consumption
- High temperature range
- Positive supply voltage
- 24L-QFN 4x4 SMD Leadless package

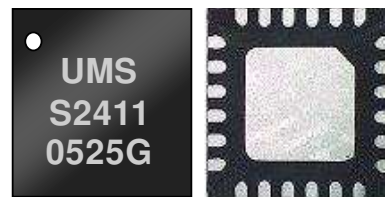

Plastic Package

#### Main Electrical Characteristics

T<sub>amb.</sub> = +25°C

Symbol	Parameter	Min	Typ	Max	Unit
Freq	Frequency range	23		26	GHz
IL	Insertion loss		2.9	4	dB
Iso	Isolation	32	35		dB
RLoss	Return Loss		-15		dB

ESD Protection: Electrostatic discharge sensitive device. Observe handling precautions!

## Electrical Characteristics

Symbol	Parameter	Min	Typ	Max	Unit
Freq	Frequency range	23		26	GHz
Iso	Isolation	32	35		dB
Il	Insertion loss		2.9	4	dB
RI	Return loss		-15		dB
P1dB	Input power at 1 dBc@24GHz	18	23.5		dBm
Ssp	Switching speed		30		ns
Top	Operating temperature range	-40		105	°C
Vdd/5V	Positive Supply Voltage		5		V
Idd/5V	$\Sigma$ of the current on the supply ports <sup>(1)</sup>		3.3	4.3	mA
$\Sigma P_i$ <sup>(2)</sup>	$\Sigma$ of the current on the control ports		3	3.7	mA
$P_i$ <sup>(2)</sup>	OFF state Control Voltage (High state)		5		V
$P_i$ <sup>(2)</sup>	ON state Control Voltage (Low State)		0		V

<sup>(1)</sup> pin6 and 13: see QFN Pin-out description

<sup>(2)</sup> Note that it's specified for each  $P_i$ , with  $i = 1, 2, 3, 4$ .

By design the ports OUT1 and OUT2 are respectively symmetrical to ports OUT4 and OUT3. These performances has been obtained with the chip in QFN package attached on the recommended boards (ref. 97298) described in the document. The performances are highly dependent on this environment.

## For information only

The main parameters below are obtained from 3 samples mounted on the board ref. 97298 (room temperature).

ON/OFF state control voltage	Typical			
	Insertion loss (dB)	Isolation (dB)	Return loss (dB)	Input power @1dB comp. (dBm)
0V/5V	2.9	-35	-15	>22
1V/5V	3.1	-35	-15	16.4
2V/5V	3.7	-35	-15.5	<9
0V/4.5V	3.1	-35	-15.5	19.8
0V/4V	3.0	-35	-15.5	22
0.5V/4V	3.1	-35	-15.5	17.4
1V/4V	3.1	-35	-15	14
2V/4V	Not fonctionnal	Not fonctionnal	Not fonctionnal	Not fonctionnal

**Absolute Maximum Ratings** <sup>(1)</sup>

Symbol	Parameter	Values	Unit
Vdd	Positive supply voltage	6	V
Pin	Maximum peak input power overdrive	26	dBm
Top	Operating temperature range	-40 to +105	°C
Tstg	Storage temperature range	-55 to +150	°C

<sup>(1)</sup> Operation of this device above any one of these parameters may cause permanent damage.

**Truth Table**

Control Pin				Signal Path State			
P1	P2	P3	P4	IN / Out1	IN / Out2	IN / Out3	IN / Out4
Low	High	High	High	ON	OFF	OFF	OFF
High	Low	High	High	OFF	ON	OFF	OFF
High	High	Low	High	OFF	OFF	ON	OFF
High	High	High	Low	OFF	OFF	OFF	ON

Typical QFN measurements on board with probes (QFN plan)

Typical Sij Parameters vs Frequency in QFN package plans  
(RF - OUT1 path)

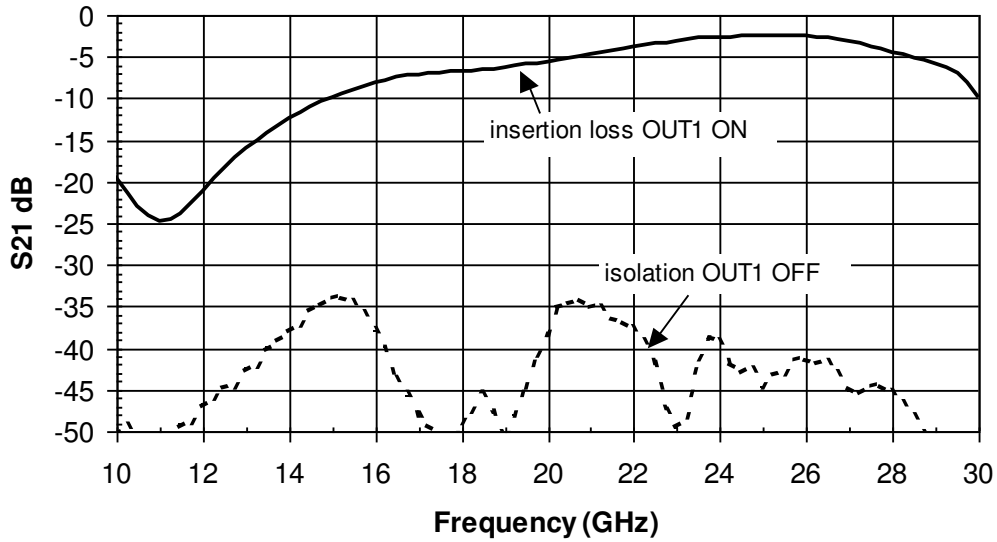

Typical Sij Parameters vs Frequency in QFN package plans  
(RF - OUT1 path)

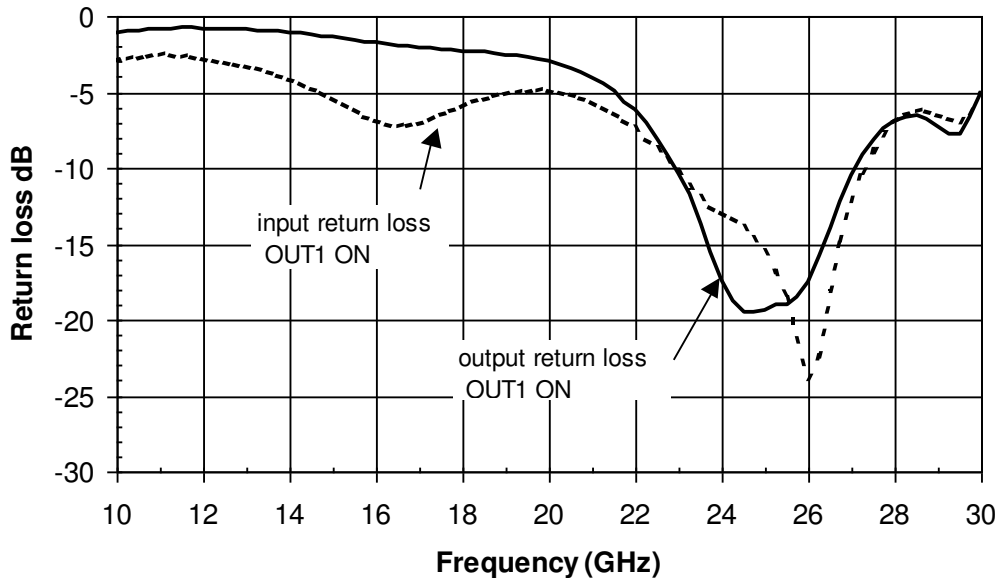

**Package outline <sup>(1)</sup>**

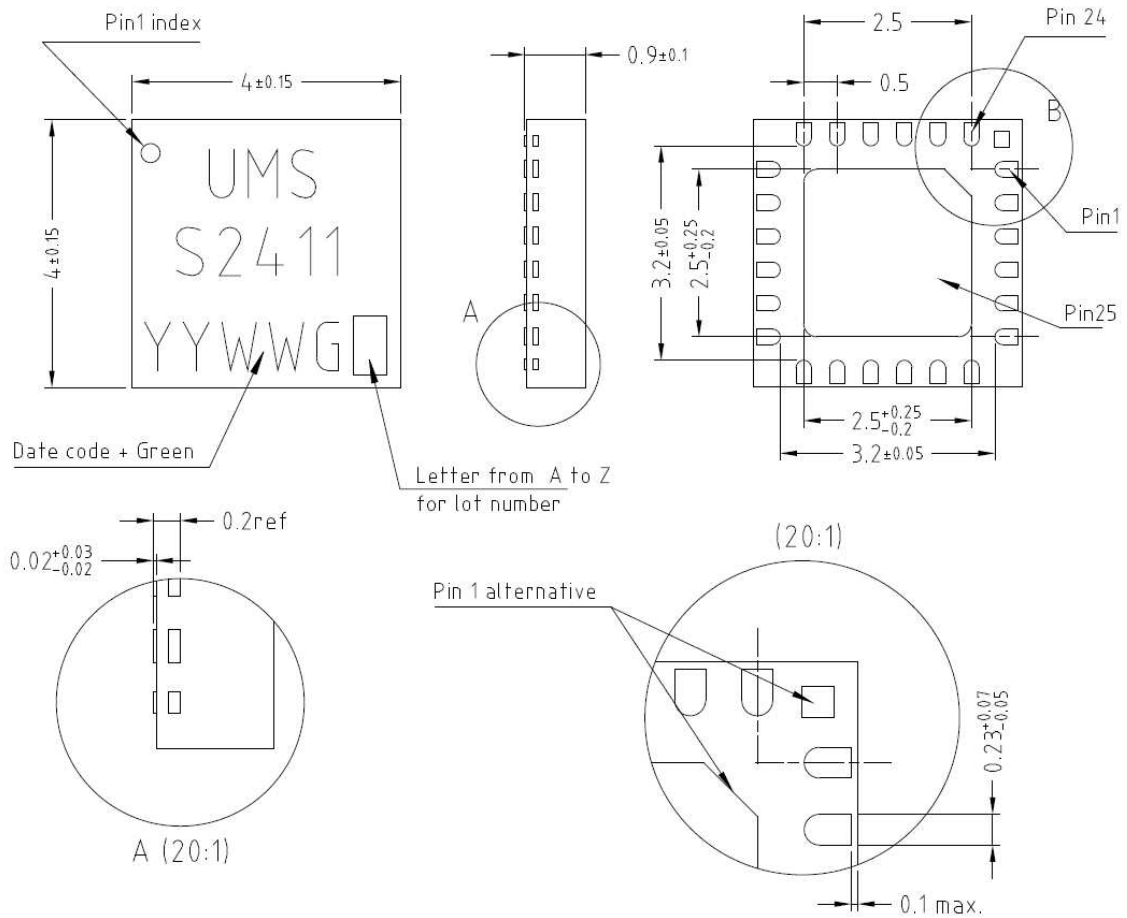

Matt tin, Lead Free	(Green)	1- Nc	9- RF in	17- P2
Units :	mm	2- P3	10- Gnd <sup>(2)</sup>	18- Nc
From the standard :	JEDEC MO-220	3- Gnd <sup>(2)</sup>	11- Gnd <sup>(2)</sup>	19- Gnd <sup>(2)</sup>
	(VGGD)	4- RF <sub>out4</sub>	12- P1	20- RF <sub>out2</sub>
	25- GND	5- Gnd <sup>(2)</sup>	13- Vd <sup>(3)</sup>	21- Gnd <sup>(2)</sup>
		6- Vd <sup>(3)</sup>	14- Gnd <sup>(2)</sup>	22- Gnd <sup>(2)</sup>
		7- P4	15- RF <sub>out1</sub>	23- RF <sub>out3</sub>
		8- Gnd <sup>(2)</sup>	16- Gnd <sup>(2)</sup>	24- Gnd <sup>(2)</sup>

<sup>(1)</sup> The package outline drawing included in this data-sheet is given for indication. Refer to the application note AN0017 (<http://www.ums-gaas.com>) for exact package dimensions.

<sup>(2)</sup> It is strongly recommended to ground all pins marked “Gnd” through the PCB board. Ensure that the PCB board is designed to provide the best possible ground to the package.

<sup>(3)</sup> Vd = +5V.

## Evaluation mother board

- Compatible with the proposed footprint.
- Based on typically Ro4003 / 8mils or equivalent.
- Using a micro-strip to coplanar transition to access the package.
- Recommended for the implementation of this product on a module board.
- See application note AN0017 for details.

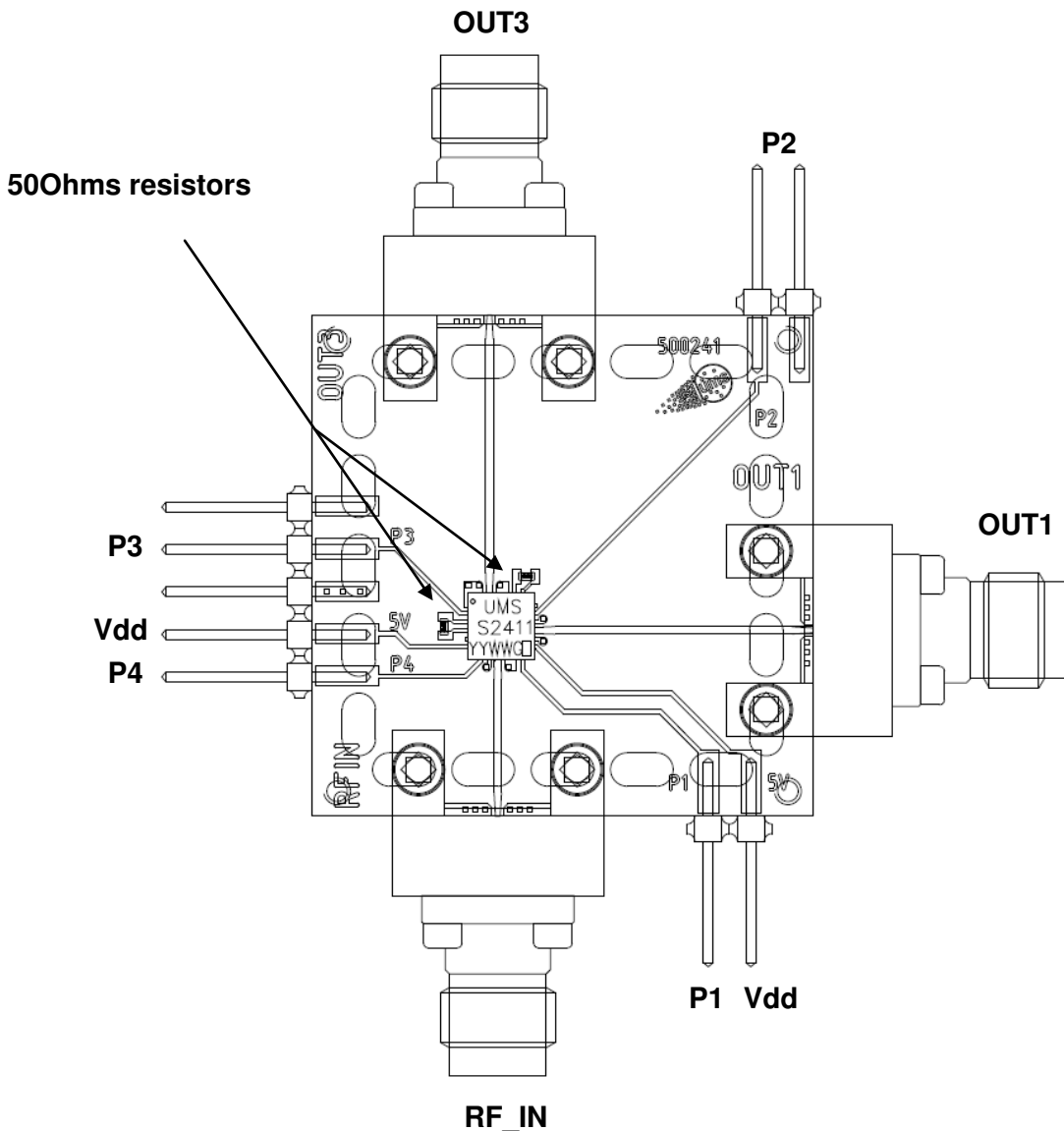

**Recommended Test Fixture (Ref. 97298) for measurements in the package's plans with probes**

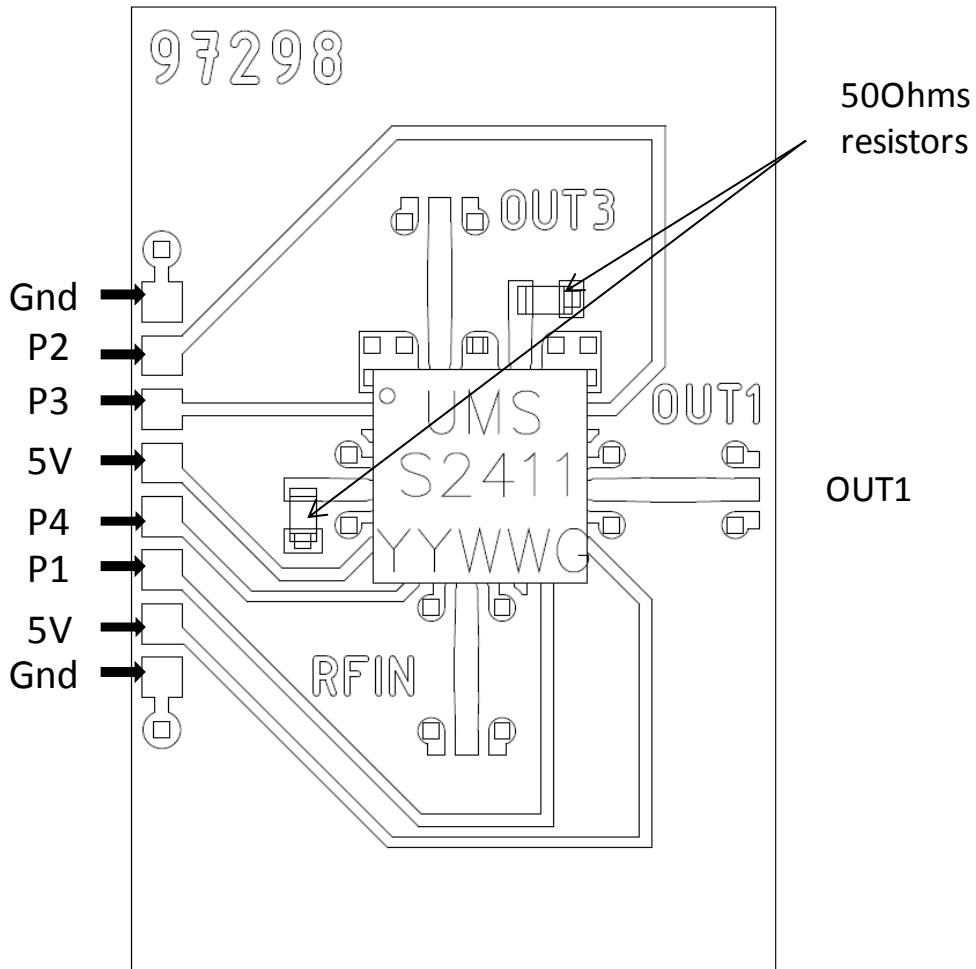

## Bias configuration

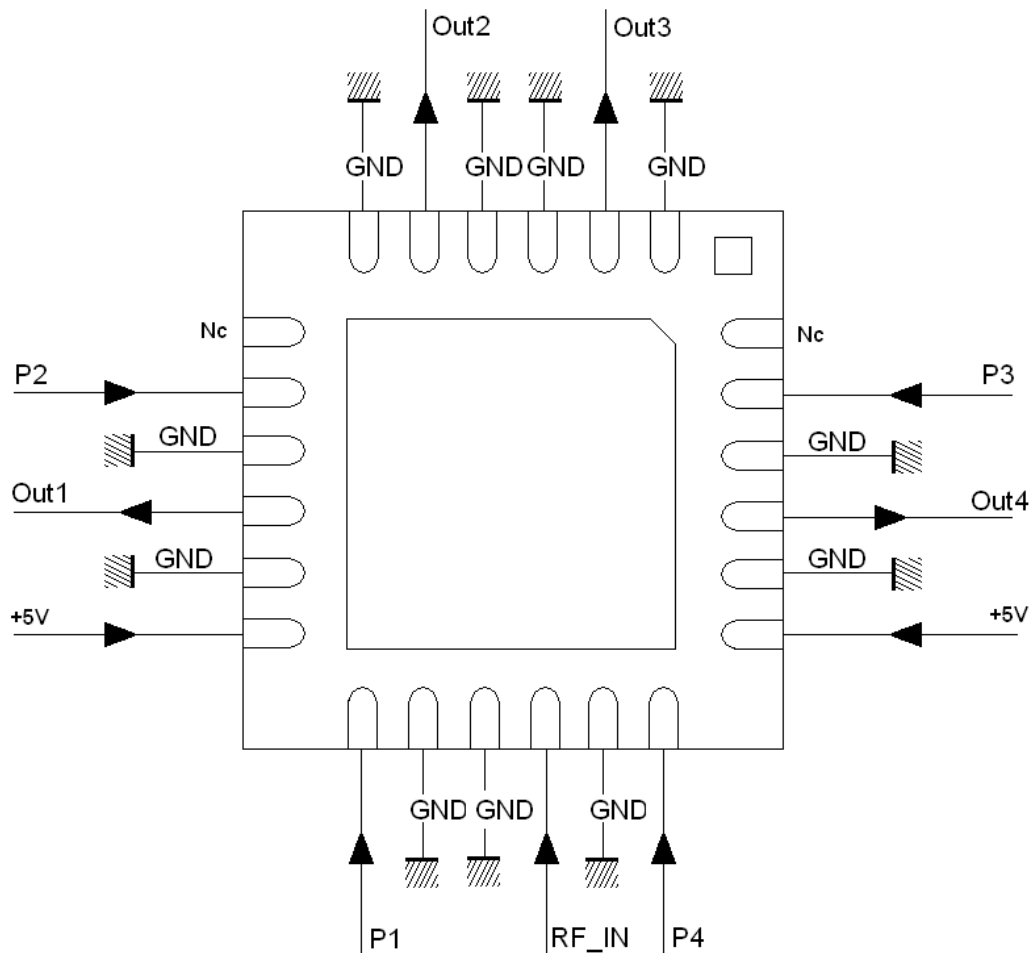

## ESD sensitivity

Standard	Value
MIL-STD-1686C	HBM Class 1 (<2000V)
ESD STM5.1-1998	HBM Class 0 (<250V)

## Package Information

Parameter	Value
Package body material	RoHS-compliant
	Low stress Injection Molded Plastic
Lead finish	100% matte Sn
MSL Rating	MSL1

**Notes**

To cope with CHS2411-QDG high volume production for Automotive radar, UMS has developed and qualified a dual source part named CHS2412-QDG. It provides the same electrical and thermal performances, identical pin out and packaging and meets the same quality standard as CHS2411-QDG. It is compatible with Automotive production flow. The dual source CHS2412-QDG is recognized by package marking S2412.

## Recommended package footprint

Refer to the application note AN0017 available at <http://www.ums-gaas.com> for package footprint recommendations.

## SMD mounting procedure

For the mounting process standard techniques involving solder paste and a suitable reflow process can be used. For further details, see application note AN0017.

## Recommended environmental management

UMS products are compliant with the regulation in particular with the directives RoHS N°2011/65 and REACH N°1907/2006. More environmental data are available in the application note AN0019 also available at <http://www.ums-gaas.com>.

## Recommended ESD management

Refer to the application note AN0020 available at <http://www.ums-gaas.com> for ESD sensitivity and handling recommendations for the UMS package products.

## Ordering Information

QFN 4x4 package:	CHS2411-QDG/XY	
	Stick: XY = 20	Tape & reel: XY = 21
QFN 4x4 package (dual source):	CHS2411-QDG/XY	
	Stick: XY = 20	Tape & reel: XY = 21

Information furnished is believed to be accurate and reliable. However **United Monolithic Semiconductors S.A.S.** assumes no responsibility for the consequences of use of such information nor for any infringement of patents or other rights of third parties which may result from its use. No license is granted by implication or otherwise under any patent or patent rights of **United Monolithic Semiconductors S.A.S.** Specifications mentioned in this publication are subject to change without notice. This publication supersedes and replaces all information previously supplied. **United Monolithic Semiconductors S.A.S.** products are not authorised for use as critical components in life support devices or systems without express written approval from **United Monolithic Semiconductors S.A.S.**