

81-86GHz Medium Power Amplifier

GaAs Monolithic Microwave IC

Description

The CHA3090-98F is a three-stage monolithic Medium Power Amplifier. This circuit includes a power detector which integrates a directional coupler, a detection diode and a reference diode to be used in differential mode.

It is dedicated to E-band telecommunication, particularly well suited for the new generation of high capacity Backhaul.

The circuit is manufactured with a pHEMT process, 0.1 μ m gate length, via holes through the substrate, air bridges and electron beam gate lithography.

It is available in chip form with BCB layer protection.

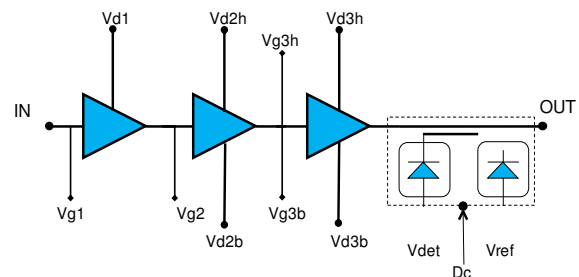

Functional diagram

Main Features

- Broadband performances: 81-86GHz
- 13dB linear gain
- 17dBm power at 1dB compression
- 20dB power detector dynamic range
- BCB layer protection
- DC bias: Vd=3.5V@Id=280mA
- Chip size 3.36x1.78x0.07mm

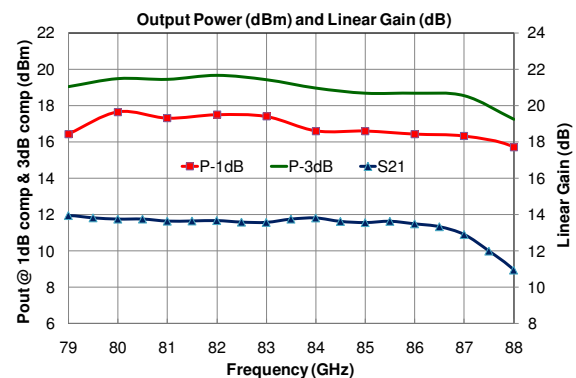

Main Electrical Characteristics

Tamb.= +25°C

Symbol	Parameter	Min	Typ	Max	Unit
Freq	Frequency range	81		86	GHz
Gain	Linear Gain		13		dB
P1dB	Output Power @1dB comp.		17		dBm
Psat	Saturated Output Power		19		dBm
Dr	Detection dynamic range (for output power detection up to Psat)		20		dB

Electrical Characteristics

Tamb.= +25°C, Vd = Dc = 3.5V, Id (quiescent) = 280mA

Symbol	Parameter	Min	Typ	Max	Unit
Freq	Frequency range	81		86	GHz
Gain	Linear Gain		13		dB
P1dB	Output power @ 1dB compression		17		dBm
Psat	Saturated Output Power		19		dBm
Dr	Detection dynamic range (for output power detection up to Psat)		20		dB
Vdetect	Voltage detection Vref-Vdet up to Psat		50 to 1400		mV
RLin	Input Return Loss		8		dB
RLout	Output Return Loss		12		dB
Gain ctrl	Gain control range with Vg1&Vg2 tuning (with Vd fixed at 3.5V)		10		dB
NF	Noise Figure		4.0		dB
Vd1, Vd2h, Vd3h, Vd2b, Vd3b	Drain supply voltage		3.5		V
Id	Supply quiescent current		280		mA
Vg1, Vg2, Vg3b, Vg3h	Gate supply voltage		0.15		V
Dc	Detector supply voltage		3.5		V
IDc	Detector bias current		240		μA

These values are representative of on-wafer measurements that are made without bonding wires at the RF ports but with 10kΩ resistor in parallel on pads Vdet and Vref.

A ribbon (75μm wide) connection at the input and the output of the MMIC amplifier (See chapter recommended chip assembly) should improve the results.

Absolute Maximum Ratings ⁽¹⁾

Tamb.= +25°C

Symbol	Parameter	Values	Unit
Vd	Drain bias voltage	4V	V
Id	Drain bias current	350	mA
Vg	Gate bias voltage	-2 to +0.4	V
Pin	Maximum continuous input power	+12	dBm
Tj	Junction temperature	175	°C
Ta	Operating temperature range	-40 to +85	°C
Tstg	Storage temperature range	-55 to +150	°C

⁽¹⁾ Operation of this device above anyone of these parameters may cause permanent damage.

Typical on-wafer Sij parameters

Tamb.= +25°C, Vd = Dc = 3.5V, Id (quiescent) = 280mA

Freq (GHz)	S11 (dB)	PhS11 (°)	S21 (dB)	PhS21 (°)	S12 (dB)	PhS12 (°)	S22 (dB)	PhS22 (°)
60	-1.93	130.9	-26.09	72.3	-41.2	-79.7	-3.51	-177.5
61	-2.69	129.1	-21.66	80.7	-45.04	-34.3	-3.79	168.5
62	-2.77	127.5	-16.72	70.0	-44.41	-147.6	-5.11	158.6
63	-3.34	118.0	-12.79	33.4	-44.79	-163.0	-8.23	139.2
64	-4.51	117.5	-7.88	4.3	-56.26	46.6	-14.98	139.6
65	-3.82	112.4	-6.1	-29.5	-42.61	-117.1	-16.1	-133.2
66	-2.56	107.6	-4.52	-54.8	-48.11	-163.5	-8.49	-138.4
67	-2.93	94.8	-2.97	-86.3	-60.04	172.8	-7.54	-125.1
68	-2.82	89.0	-1.24	-114.5	-58.99	161.0	-5.06	-157.1
69	-3.12	78.6	0.57	-141.7	-63.33	119.1	-3.08	-162.4
70	-3.24	67.5	2.33	-166.3	-58.85	38.3	-3.19	-179.3
71	-3.57	54.6	4.97	166.3	-52.89	11.8	-2.63	167.6
72	-4.21	36.3	7.62	129.1	-53.16	-17.2	-2.41	158.4
73	-5.67	15.1	10.15	92.3	-47.26	-31.3	-2.87	139.8
74	-9.04	-11.8	12.3	48.2	-42.71	-45.5	-3.65	122.2
75	-14.38	-13.9	12.86	6.4	-39.03	-84.7	-6.03	117.7
76	-15.07	0.2	13.17	-36.0	-39.29	-130.6	-7.61	109.5
77	-13.81	-12.6	13.2	-73.6	-42.29	-173.4	-7.98	103.5
78	-13.32	-38.5	13.31	-109.7	-48.37	148.8	-9.39	92.4
79	-13.16	-69.7	13.29	-145.7	-62.34	84.1	-10.6	82.7
80	-13.87	-104.8	12.95	178.2	-52.79	-87.1	-12.44	86.0
81	-13.98	-120.6	12.64	145.3	-53.89	-168.0	-13.06	71.0
82	-12.47	-143.5	12.75	110.1	-50.06	-75.9	-14.07	53.0
83	-10.43	-156.0	12.8	76.8	-43.17	-107.0	-16.27	40.9
84	-8.91	-176.1	13.29	37.4	-40.54	-137.0	-18.44	27.0
85	-7.46	168.0	13.18	-2.2	-39.05	-165.6	-20.89	7.8
86	-5.5	148.7	13.13	-45.2	-38.12	166.2	-25.18	9.7
87	-3.78	125.2	12.71	-93.6	-37.8	128.6	-23.56	59.7
88	-2.8	98.0	10.99	-143.9	-39.17	89.5	-16.6	34.7
89	-3.06	72.4	7.94	168.1	-41.29	53.6	-13.36	0.6
90	-3.86	49.5	4.31	127.0	-44.06	14.3	-12.05	-27.5
91	-4.76	29.9	0.36	91.4	-49.06	-32.7	-11.47	-52.0
92	-5.42	12.8	-3.58	60.3	-53.9	-86.2	-11.36	-71.1
93	-6.27	-3.2	-7.09	32.3	-53.13	-160.7	-11.64	-87.7
94	-7.05	-19.1	-10.7	4.5	-48.1	119.9	-11.87	-101.2
95	-7.57	-33.4	-14.16	-17.5	-41.63	22.4	-12	-110.6
96	-8.29	-48.4	-17.21	-40.7	-42.94	-40.2	-12.42	-123.7
97	-8.79	-63.5	-21.07	-65.1	-45.34	-76.4	-13.02	-136.0
98	-9.17	-76.6	-25.38	-82.2	-45.24	-86.6	-13.96	-146.1
99	-9.51	-91.0	-26.36	-71.3	-42.25	-92.4	-15.65	-152.1
100	-9.61	-106.8	-25.59	-108.0	-37.21	-125.1	-15.45	-164.6

Typical on wafer Measurements

Tamb.= +25°C, Vd = Dc = 3.5V, Id (quiescent) = 280mA

Gain & Return loss versus frequency

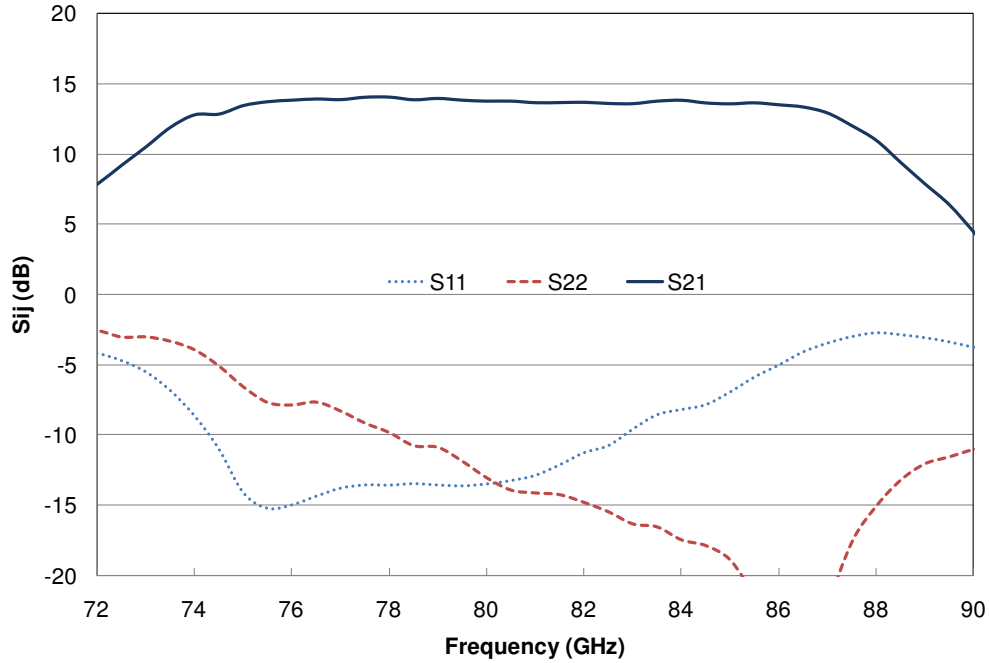

Output power at 1 & 3 dB compression

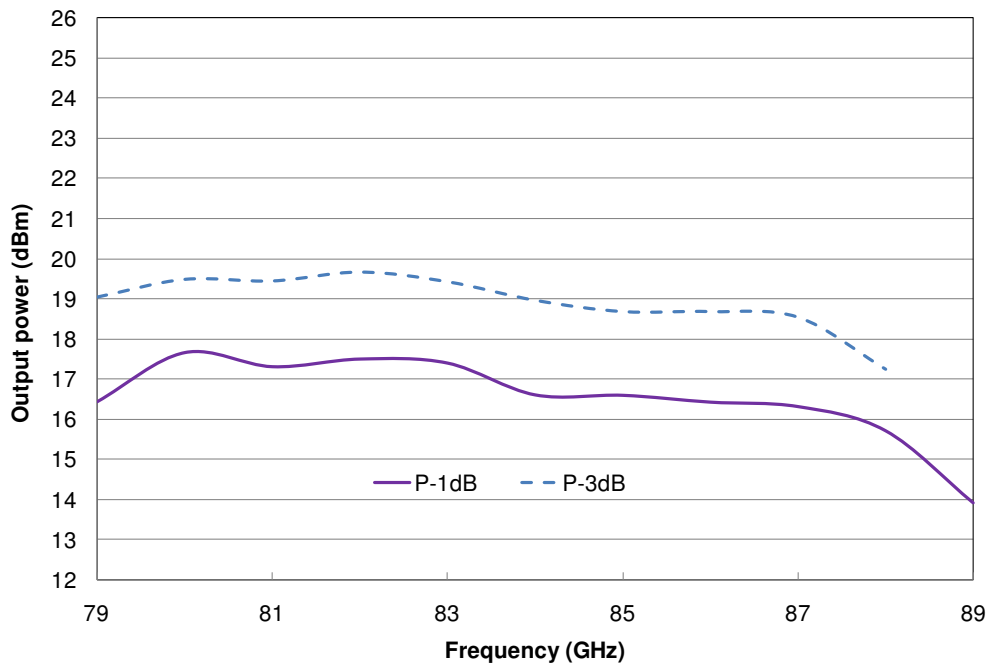

Typical on wafer Measurements

Tamb.= +25°C, Vd = Dc = 3.5V, Id (quiescent) = 280mA

Gain & output power versus input power

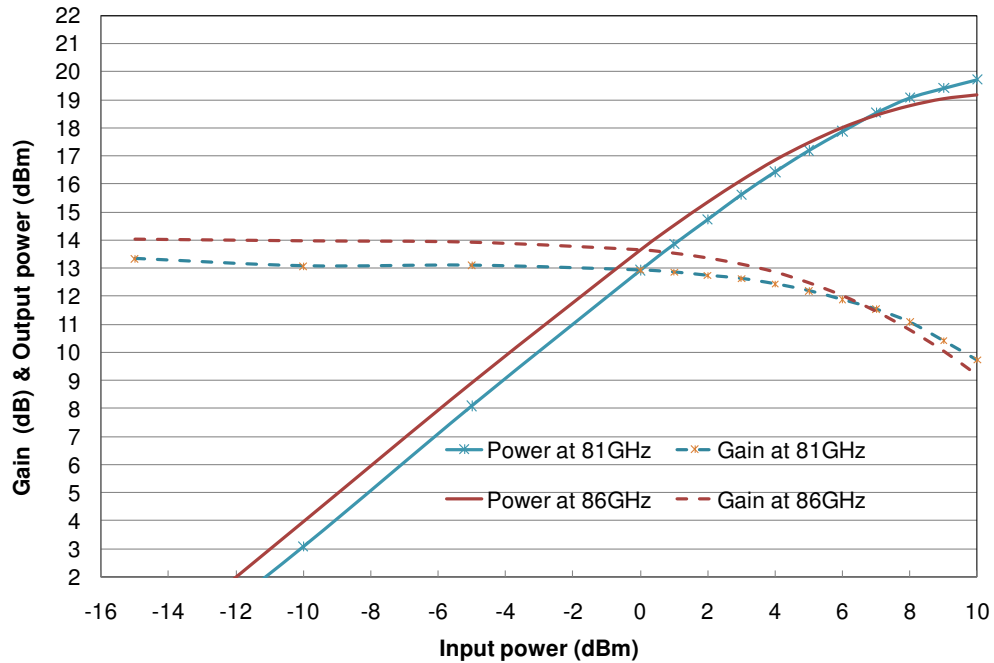

Power detection versus output power
Differential voltage

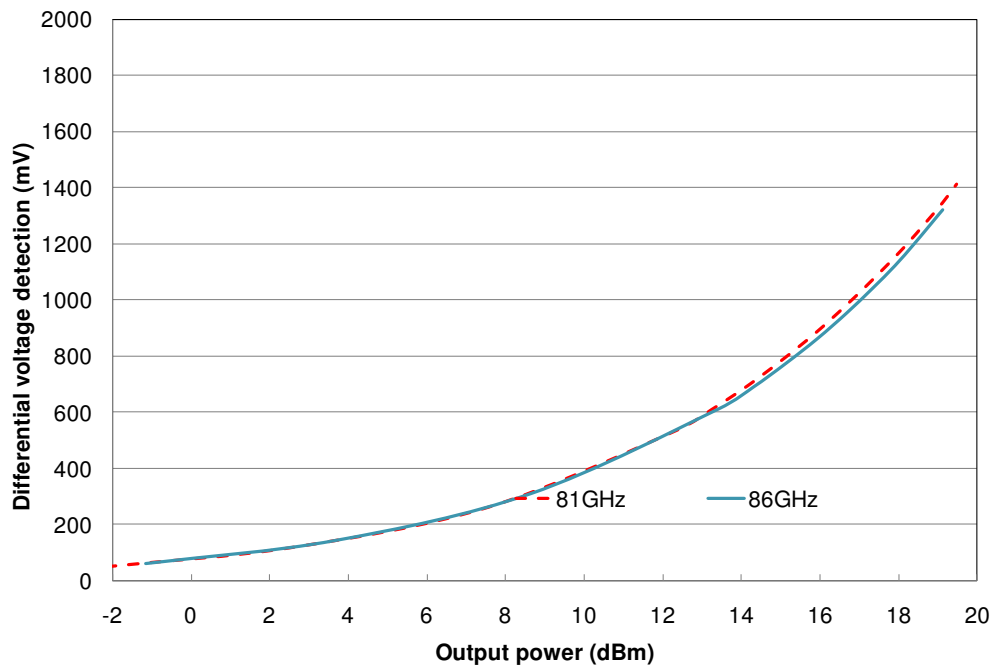

Typical Test Fixture Measurements

Tamb.= -40°C / +25°C / +85°C, Vd = +3.5V, Vg = +0.15V

Id= 330 mA @ -40°C / 280 mA @ +25°C / 245mA @ +85°C

Measurements are given in the test fixture access plans

Linear Gain versus Temperature

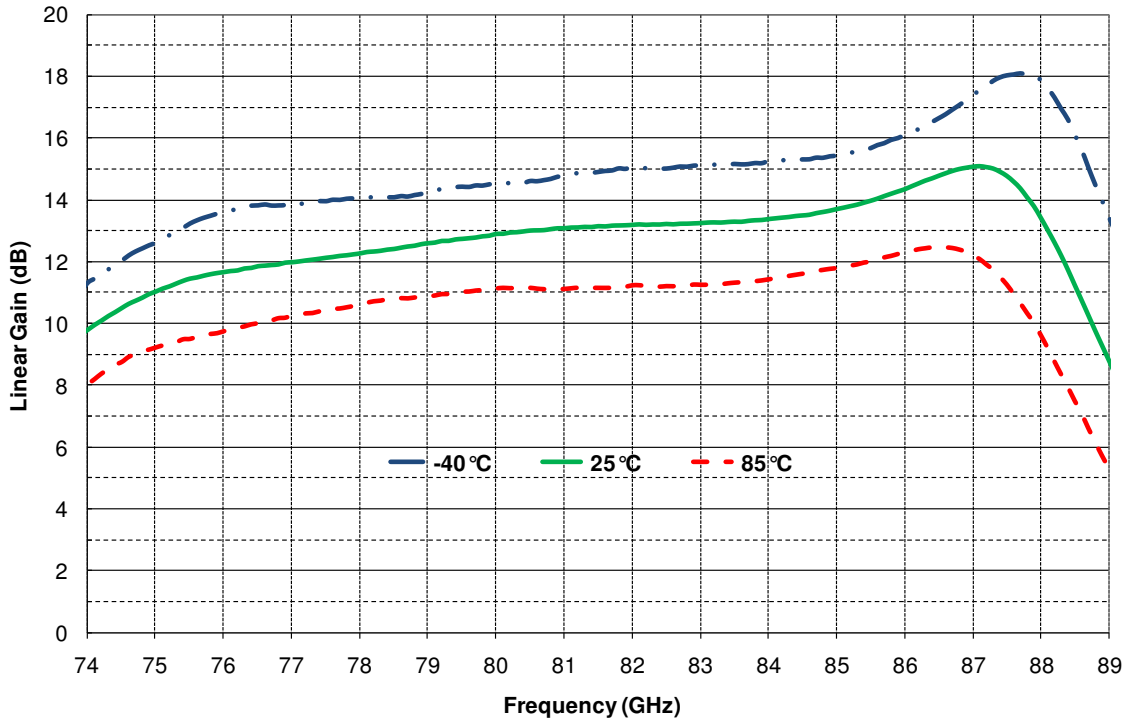

Input Return Loss versus Temperature

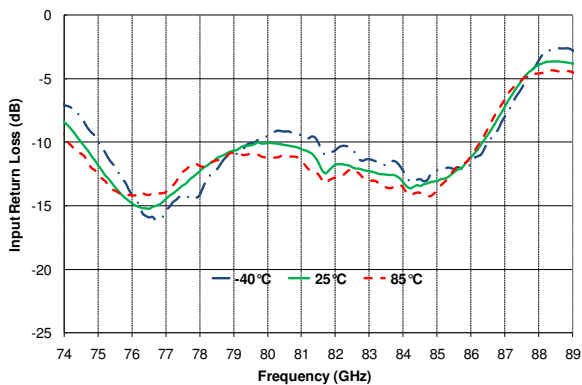

Output Return Loss versus Temperature

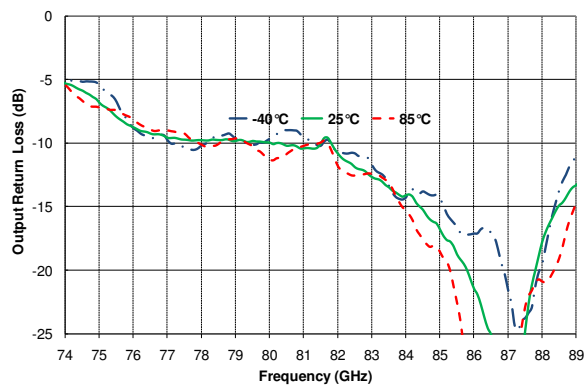

Mechanical data

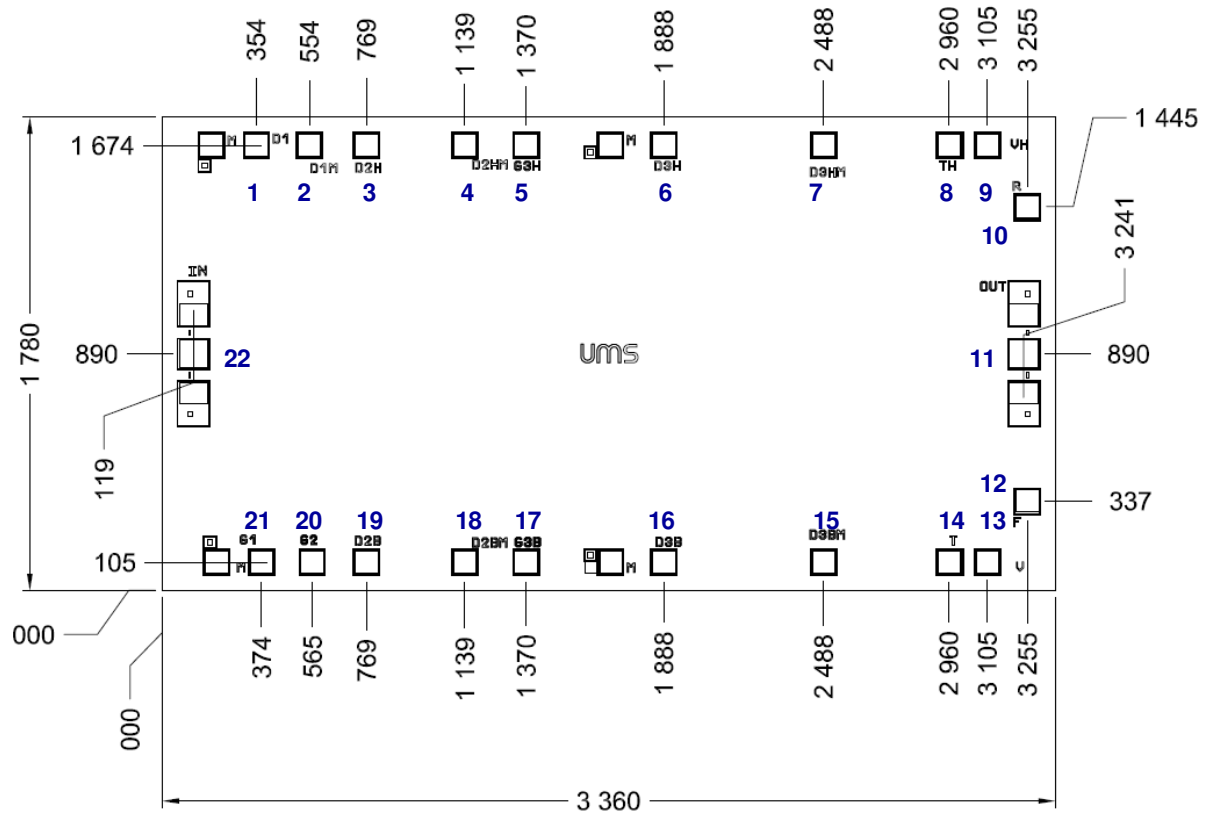

Chip thickness: 70µm.
 Chip size: 3360x1780 ±35µm
 All dimensions are in micrometers

RF Pads = 108 x 106 (BCB opening)
 DC Pads = 86 x 83 (BCB opening)

Recommended circuit bonding table

Pad number	Pad name	Description
1, 3, 6	D1; D2H; D3H	Drain voltage (3.5V, 160mA)
16, 19	D3B, D2B	Drain voltage (3.5V, 120mA)
5	G3H	Gate voltage (0.15V)
17, 20, 21	G3B, G2, G1	Gate voltage (0.15V)
14	T	Detector output
12	F	Detector reference output
13	V	DC voltage detector (3.5V, 240 μ A)
22	IN	RF in
11	OUT	RF out
2, 4, 7	D1M; D2HM; D3HM	Not connected
15, 18	D3BM, D2BM	Not connected
8, 9, 10	TH, DH, R	Not connected
	M	Not connected

Recommended assembly plan

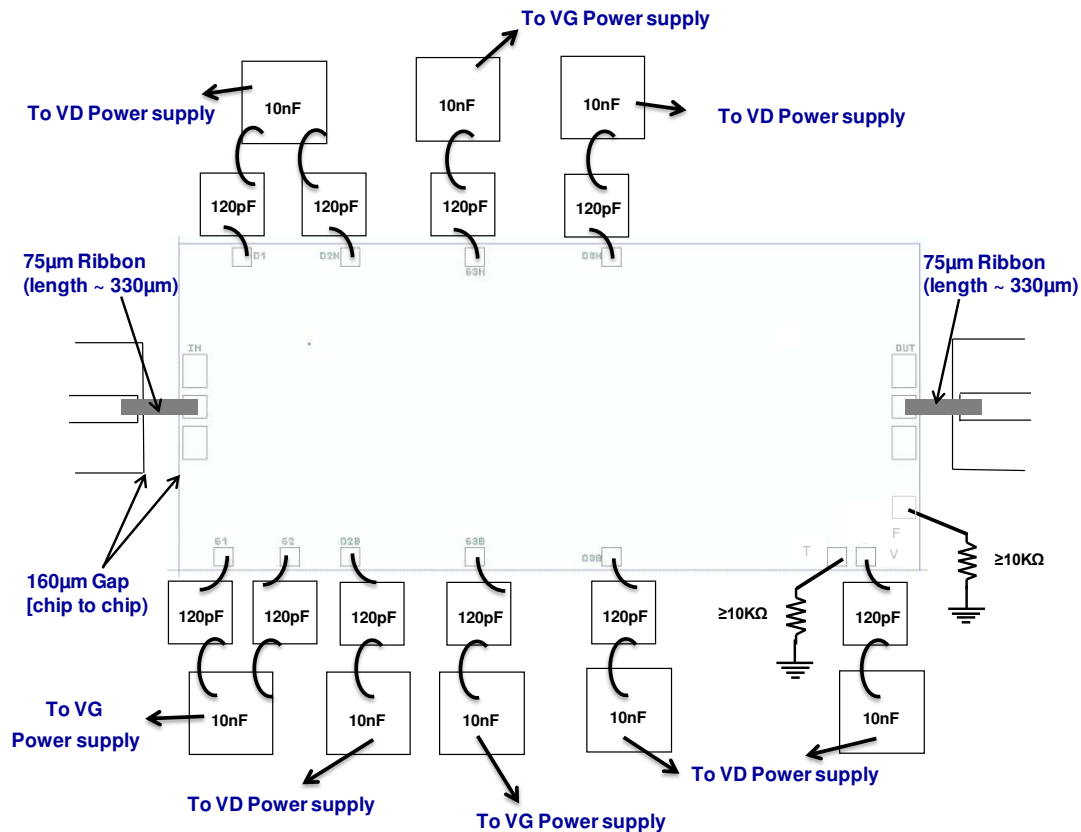

The design of the circuit integrates a half ribbon (75µm wide) connection at the input and the output of the MMIC amplifier compliant with a 50 Ohm line on GaAs MMIC. The circuits have to be as close as possible to each other; the ribbon length must be as short as possible: typically 160µm gap between two chips is considered, and the loop height must also be the smallest possible (80µm).

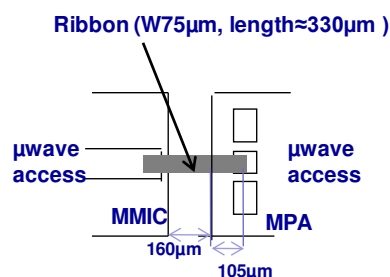

A second solution is to use wires ($\varnothing 25\mu\text{m}$). In this case a minimum of two wires together with the same chip to chip distance mention above are necessary to reduce the inductance effect. Nevertheless, simulations show an improvement of RF performance for E-band frequency range with the use of ribbon connection instead of wire.

For DC connection (DC pads), a 25µm bonding is preferred.

Due to BCB coating on the chip, qualification domain requires the chip to be glued.

DC Schematic

3.5V, 280mA

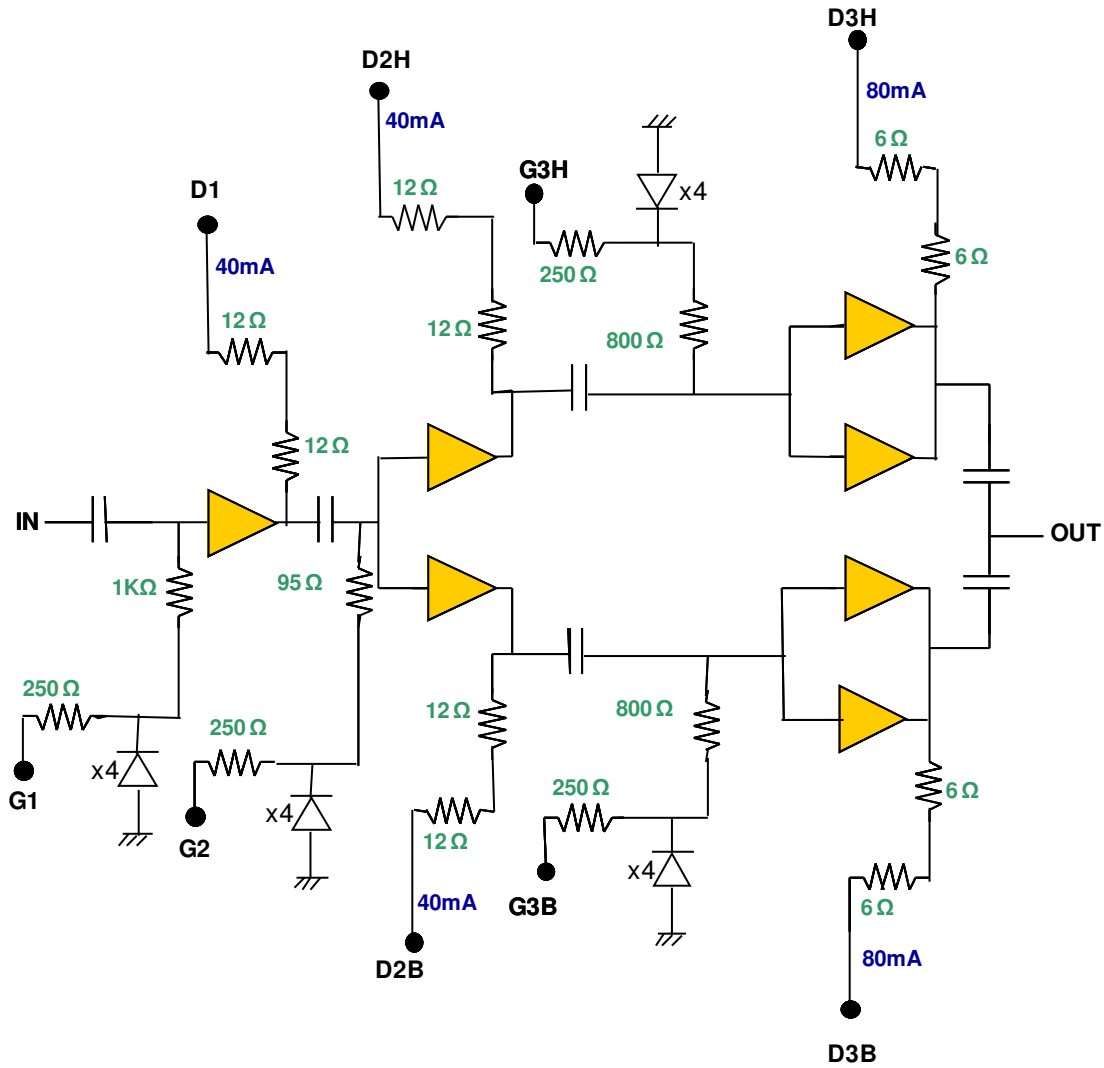

Detector

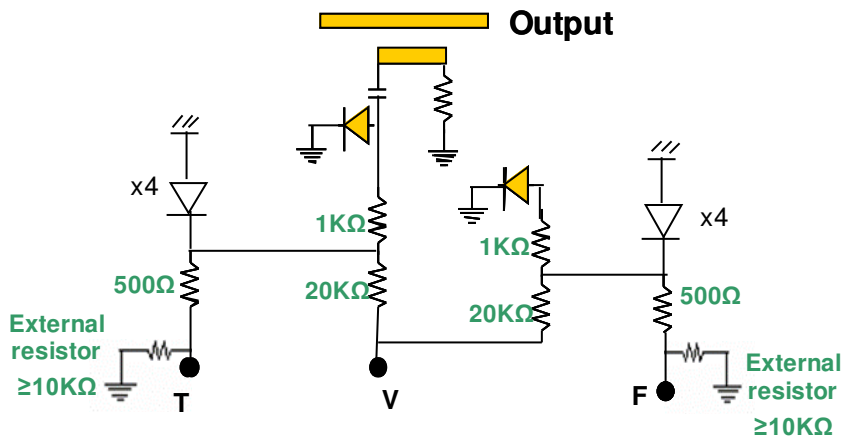

Notes

Recommended ESD management

Refer to the application note AN0020 available at <http://www.ums-gaas.com> for ESD sensitivity and handling recommendations for the UMS products.

Recommended environmental management

UMS products are compliant with the regulation in particular with the directives RoHS N°2011/65 and REACH N°1907/2006. More environmental data are available in the application note AN0019 also available at <http://www.ums-gaas.com>.

Ordering Information

Chip form:

CHA3090-98F/00

Information furnished is believed to be accurate and reliable. However **United Monolithic Semiconductors S.A.S.** assumes no responsibility for the consequences of use of such information nor for any infringement of patents or other rights of third parties which may result from its use. No license is granted by implication or otherwise under any patent or patent rights of **United Monolithic Semiconductors S.A.S.** Specifications mentioned in this publication are subject to change without notice. This publication supersedes and replaces all information previously supplied. **United Monolithic Semiconductors S.A.S.** products are not authorised for use as critical components in life support devices or systems without express written approval from **United Monolithic Semiconductors S.A.S.**