

17-26GHz Medium Power Amplifier

GaAs Monolithic Microwave IC

Description

The CHA5050-99F is a four stage monolithic MPA that provides typically 25.5dBm of output power associated to 20% of power added efficiency at 3dB gain compression.

It is designed for a wide range of applications, from military to commercial communication systems.

The circuit is manufactured with a pHEMT process, 0.25µm gate length, via holes through the substrate, air bridges and electron beam gate lithography.

It is available in chip form.

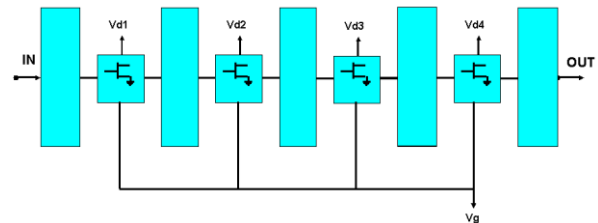

Main Features

- 0.25µm Power pHEMT Technology
- Frequency band: 17-26GHz
- Output power: 25.5dBm @ 3dBcomp
- Linear gain: 22dB
- Quiescent bias point: Vd=6V, Id=230 mA
- Chip size: 2.38x1.14x0.07mm

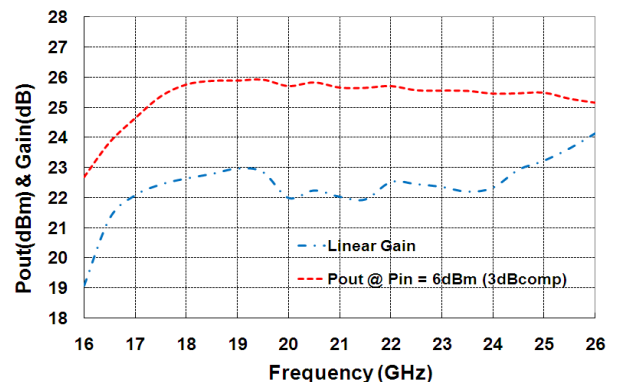

Main Electrical Characteristics

Tamb = +25°C,

Vd = 6V, Id (Quiescent) = 230 mA, CW mode.

| Symbol | Parameter | Min | Typ | Max | Unit |
|--------|-------------------------|------|------|------|------|
| Freq | Frequency range | 17.0 | | 26.0 | GHz |
| Gain | Linear Gain | | 22.0 | | dB |
| Pout | Output Power @1dB comp. | | 25.0 | | dBm |

Electrical Characteristics

Tamb = +25 °C, Vd = 6V, Id (Quiescent) = 230 mA, CW mode.

| Symbol | Parameter | Min | Typ | Max | Unit |
|----------------------------------|---|-----|------|-----|------|
| Fop | Operating frequency | 17 | | 26 | GHz |
| G | Small signal gain | | 22 | | dB |
| RLin | Input Return Loss | | 8 | | dB |
| RLout | Output Return Loss | | 10 | | dB |
| P _{-1dB} | Output power @ 1dBcomp | | 25 | | dBm |
| P _{-3dB} | Output power @ 3dBcomp | | 25.5 | | dBm |
| PAE _{-P_{-3dB}} | Power Added Efficiency @ 3dBcomp | | 20 | | % |
| Id _{-P_{-3dB}} | Supply drain current @ 3dBcomp | | 320 | | mA |
| Vd1, Vd2 | Drain supply voltage | | 6 | | V |
| Id | Supply quiescent current ⁽¹⁾ | | 230 | | mA |
| Vg | Gate supply voltage | | -0.5 | | V |

These values are representative of on-wafer measurements that are made without bonding wires at the RF ports.

A bonding wire of typically 0.2 to 0.25nH will improve the matching at the accesses.

Absolute Maximum Ratings ⁽¹⁾

Tamb. = +25 °C

| Symbol | Parameter | Values | Unit |
|-------------------|----------------------------------|-------------|------|
| Cmp | Compression level ⁽²⁾ | 8 | dB |
| Vd | Supply voltage ⁽³⁾ | 8 | V |
| Id | Supply quiescent current | 400 | mA |
| Id _{sat} | Supply current in saturation | 450 | mA |
| Vg | Supply voltage | -0.2 | V |
| Tj | Maximum junction temperature | 175 | °C |
| Tstg | Storage temperature range | -55 to +150 | °C |

⁽¹⁾ Operation of this device above anyone of these parameters may cause permanent damage.

⁽²⁾ Duration < 1s.

⁽³⁾ Without RF input power.

Typical Bias Conditions

Tamb. = +25 °C

| Symbol | Pad N° | Parameter | Values | Unit |
|--------|-------------|-------------------------------------|-----------------------|------|
| Vd | D1,D2,D3,D4 | DC drain Voltage | 6 | V |
| Vg | G1 | DC gate Voltage | ≈ -0.5 ⁽¹⁾ | V |
| Id | | DC Drain current controlled with Vg | 230 | mA |

(1) To be adjusted until to obtain Id: 230mA

Typical on-wafer Sij parameters

Tamb.= +25°C, Vd =+6V, Id =230 mA, CW mode.

| Freq (GHz) | S11 (dB) | PhS11 (°) | S12 (dB) | PhS12 (°) | S21 (dB) | PhS21 (°) | S22 (dB) | PhS22 (°) |
|------------|----------|-----------|----------|-----------|----------|-----------|----------|-----------|
| Freq | dBS11 | PhS11 | dBS12 | PhS12 | dBS21 | PhS21 | dBS22 | PhS22 |
| 1.00 | -0.06 | -11.52 | -65.84 | 129.40 | -51.96 | -45.86 | -0.10 | -11.30 |
| 2.00 | -0.11 | -22.78 | -70.73 | 150.50 | -48.12 | -131.60 | -0.08 | -22.62 |
| 3.00 | -0.19 | -34.46 | -73.59 | -100.10 | -51.41 | 142.40 | -0.12 | -34.68 |
| 4.00 | -0.37 | -46.03 | -67.18 | -35.91 | -49.98 | 31.35 | -0.20 | -47.36 |
| 5.00 | -0.59 | -57.83 | -68.21 | -41.60 | -45.46 | -69.67 | -0.41 | -60.86 |
| 6.00 | -0.82 | -69.91 | -71.44 | 93.39 | -47.85 | -138.80 | -0.70 | -75.99 |
| 7.00 | -1.19 | -82.40 | -76.13 | 130.40 | -40.31 | 160.80 | -1.38 | -93.16 |
| 8.00 | -1.69 | -95.15 | -67.42 | -117.50 | -30.30 | 105.40 | -2.72 | -111.90 |
| 9.00 | -2.40 | -108.60 | -84.26 | 56.99 | -21.08 | 41.44 | -5.15 | -130.00 |
| 10.00 | -3.38 | -122.40 | -62.14 | 7.22 | -14.37 | -29.19 | -8.57 | -143.10 |
| 11.00 | -4.78 | -137.70 | -64.54 | 10.29 | -9.26 | -89.26 | -13.11 | -155.50 |
| 12.00 | -6.88 | -153.10 | -74.45 | -129.90 | -4.29 | -141.10 | -24.33 | -154.30 |
| 13.00 | -10.60 | -167.50 | -60.49 | -134.50 | 0.96 | 170.10 | -17.65 | -33.06 |
| 14.00 | -17.65 | 176.20 | -61.05 | -145.40 | 6.61 | 119.80 | -11.24 | -44.64 |
| 15.00 | -26.57 | -66.82 | -66.18 | -129.30 | 12.67 | 64.91 | -8.42 | -61.70 |
| 16.00 | -16.13 | -80.08 | -65.08 | 73.52 | 18.72 | -2.23 | -7.18 | -78.01 |
| 17.00 | -21.30 | -97.79 | -66.74 | -179.60 | 22.17 | -84.34 | -6.45 | -95.20 |
| 18.00 | -15.82 | -41.25 | -72.50 | -132.10 | 22.90 | -156.10 | -6.81 | -113.10 |
| 19.00 | -10.26 | -49.12 | -58.77 | -174.20 | 22.60 | 141.50 | -8.92 | -129.20 |
| 20.00 | -8.27 | -63.27 | -58.87 | -172.90 | 22.26 | 86.10 | -11.55 | -131.30 |
| 21.00 | -7.38 | -72.30 | -60.64 | 161.10 | 21.86 | 36.20 | -12.56 | -121.00 |
| 22.00 | -5.87 | -82.61 | -55.85 | 99.18 | 21.95 | -12.88 | -12.77 | -119.00 |
| 23.00 | -5.69 | -94.05 | -58.92 | 121.60 | 22.12 | -57.51 | -12.01 | -122.20 |
| 24.00 | -6.05 | -105.80 | -59.39 | 116.40 | 23.02 | -104.50 | -13.18 | -136.70 |
| 25.00 | -7.30 | -111.60 | -64.00 | 22.15 | 23.74 | -156.60 | -17.84 | -131.50 |
| 26.00 | -8.80 | -108.40 | -64.31 | -12.45 | 24.33 | 148.40 | -17.29 | -80.63 |
| 27.00 | -8.62 | -94.46 | -67.93 | -130.00 | 24.12 | 87.81 | -11.71 | -73.06 |
| 28.00 | -6.47 | -86.97 | -56.53 | -164.80 | 22.73 | 26.56 | -7.99 | -83.28 |
| 29.00 | -3.83 | -88.39 | -54.45 | 162.30 | 20.39 | -32.26 | -5.80 | -98.65 |
| 30.00 | -1.90 | -98.80 | -53.49 | 174.90 | 17.48 | -89.01 | -4.42 | -114.20 |
| 31.00 | -0.89 | -111.60 | -50.44 | 160.30 | 13.75 | -142.20 | -3.54 | -129.70 |
| 32.00 | -0.51 | -122.60 | -46.61 | 136.40 | 9.64 | 169.10 | -3.07 | -144.50 |
| 33.00 | -0.28 | -132.30 | -44.40 | 116.90 | 5.36 | 124.50 | -2.66 | -159.30 |
| 34.00 | -0.33 | -140.60 | -44.16 | 80.16 | 0.96 | 81.63 | -2.46 | -174.30 |
| 35.00 | -0.19 | -147.80 | -44.33 | 67.77 | -3.56 | 41.54 | -1.93 | 170.50 |
| 36.00 | -0.17 | -154.70 | -44.49 | 39.31 | -8.48 | 1.91 | -1.69 | 154.00 |
| 37.00 | -0.17 | -160.60 | -45.12 | 24.13 | -13.91 | -35.51 | -1.36 | 136.00 |
| 38.00 | -0.16 | -166.50 | -46.36 | 7.06 | -20.14 | -70.88 | -0.82 | 116.80 |

Typical on wafer Measurements

Tamb= +25°C; Vd =6V, Id (Quiescent) =230 mA, CW mode

Linear Gain versus frequency

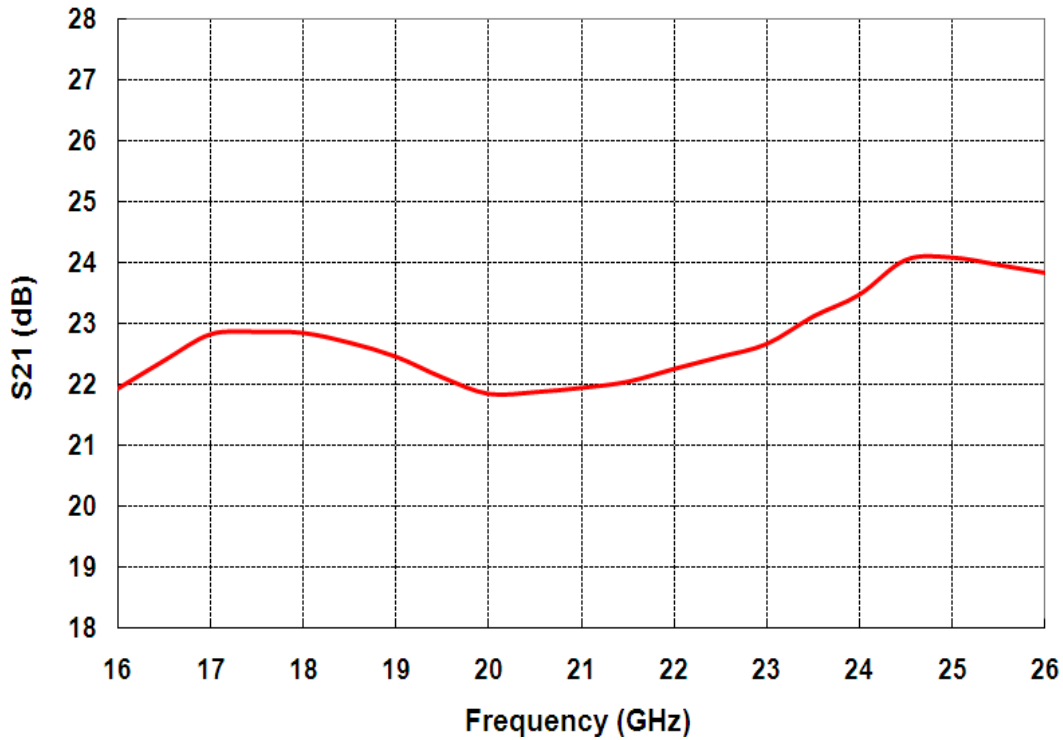

Return losses versus frequency

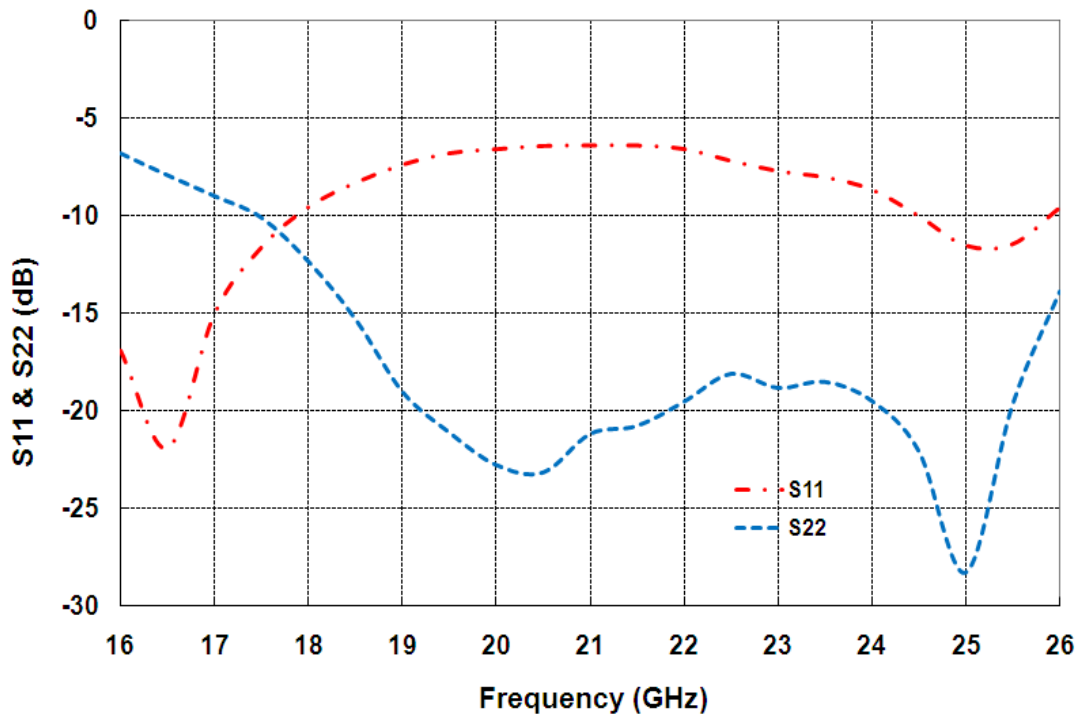

Typical Test Fixture Measurements

Temp= -40 °C, +25 °C, +85 °C; Vd =6V, Id (Quiescent) =230 mA, CW mode

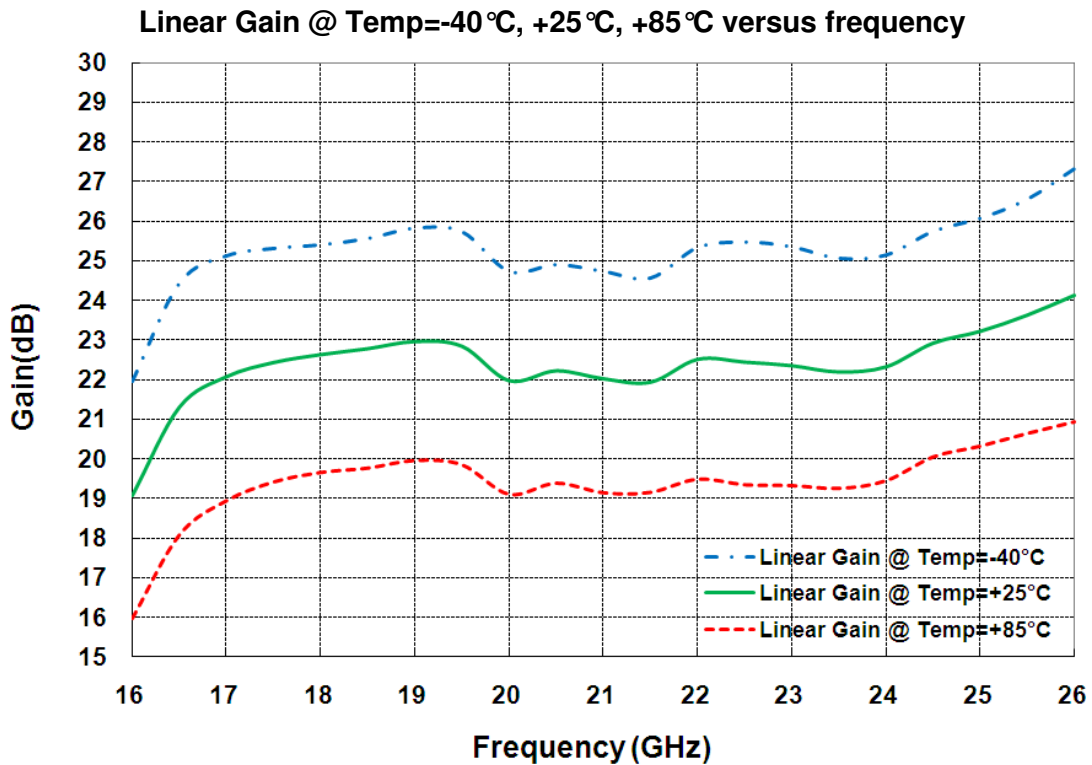

Output Power @ ≈3dBcomp & Temp=-40 °C, +25 °C, +85 °C versus frequency

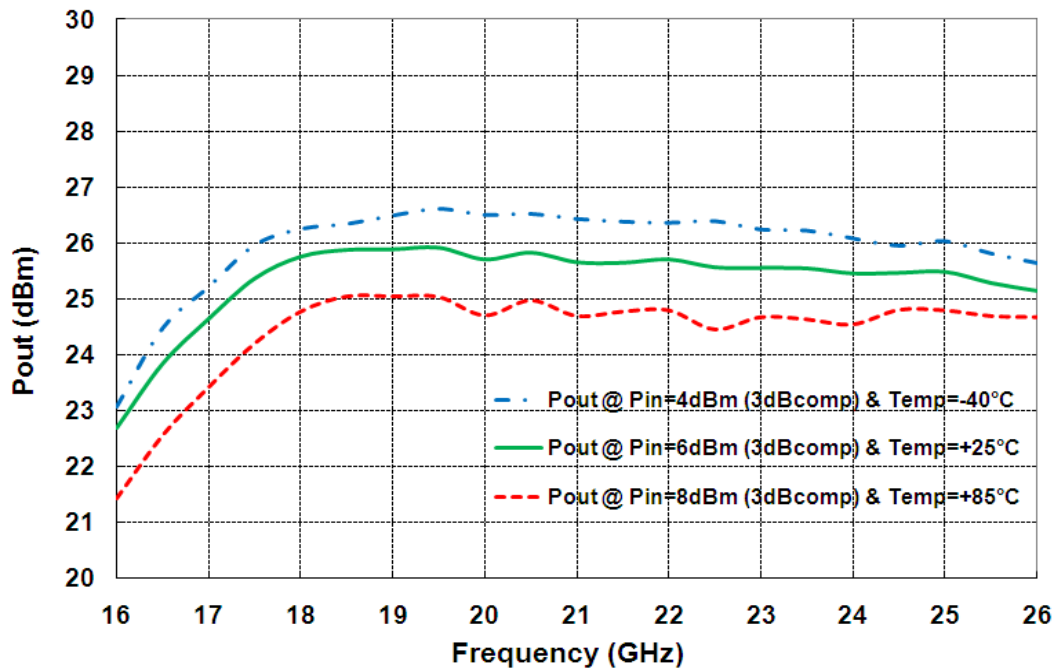

Typical Test Fixture Measurements

Temp= -40°C, +25°C, +85°C; Vd =6V, Id (Quiescent) =230 mA, CW mode

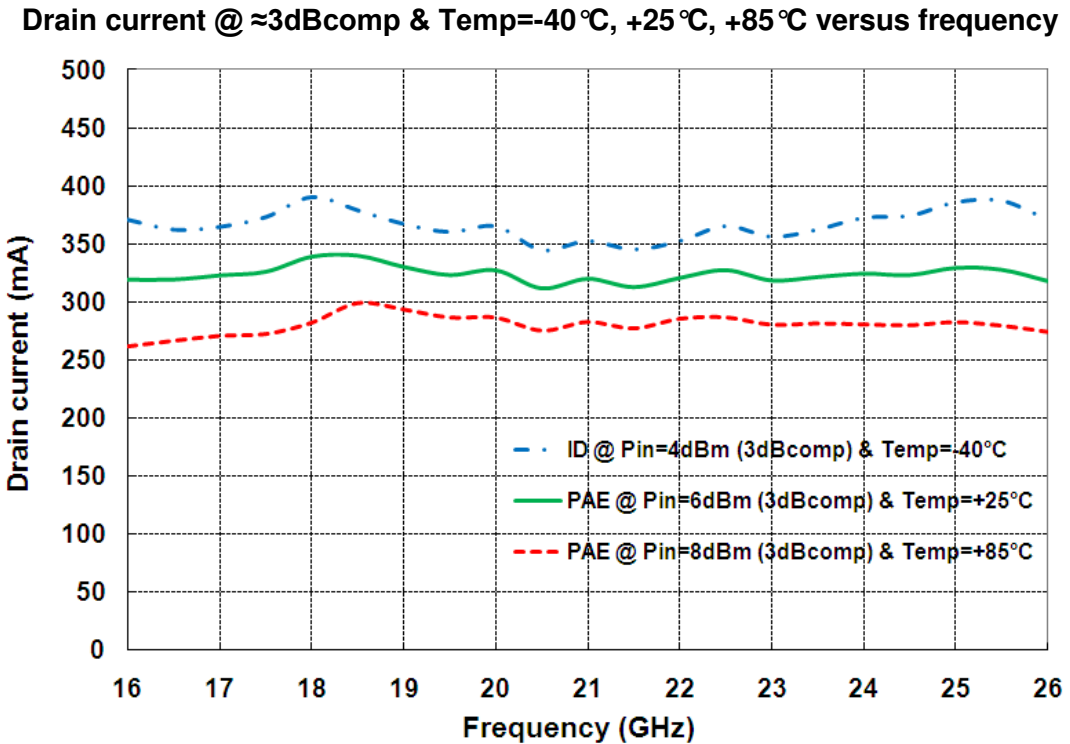
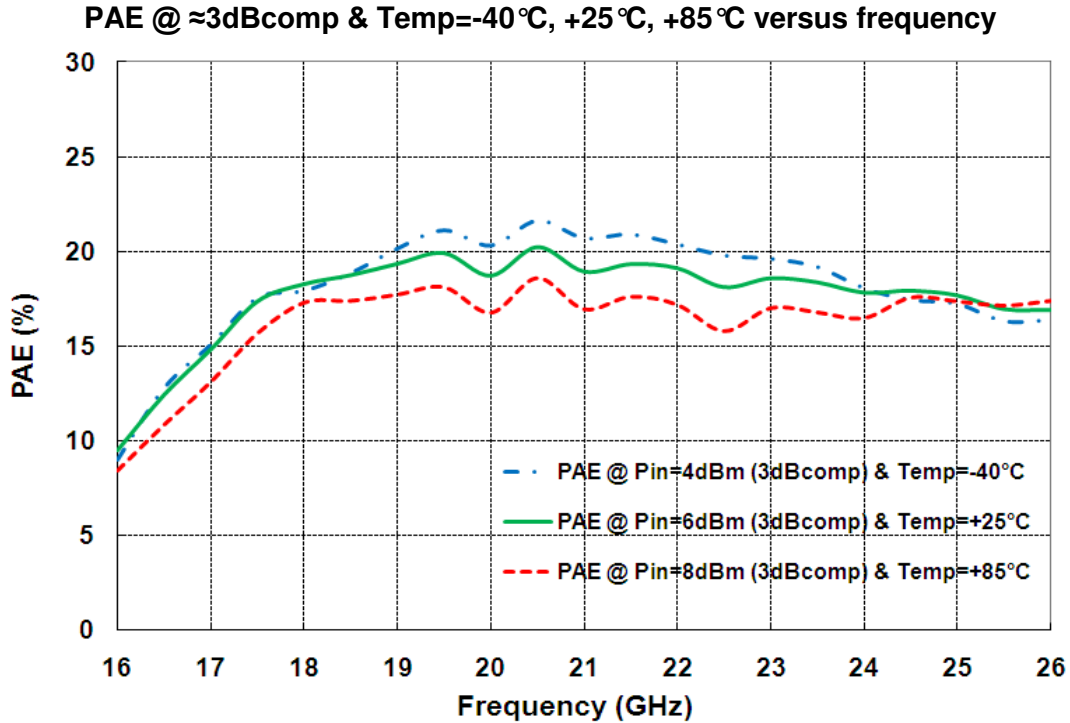

Mechanical data

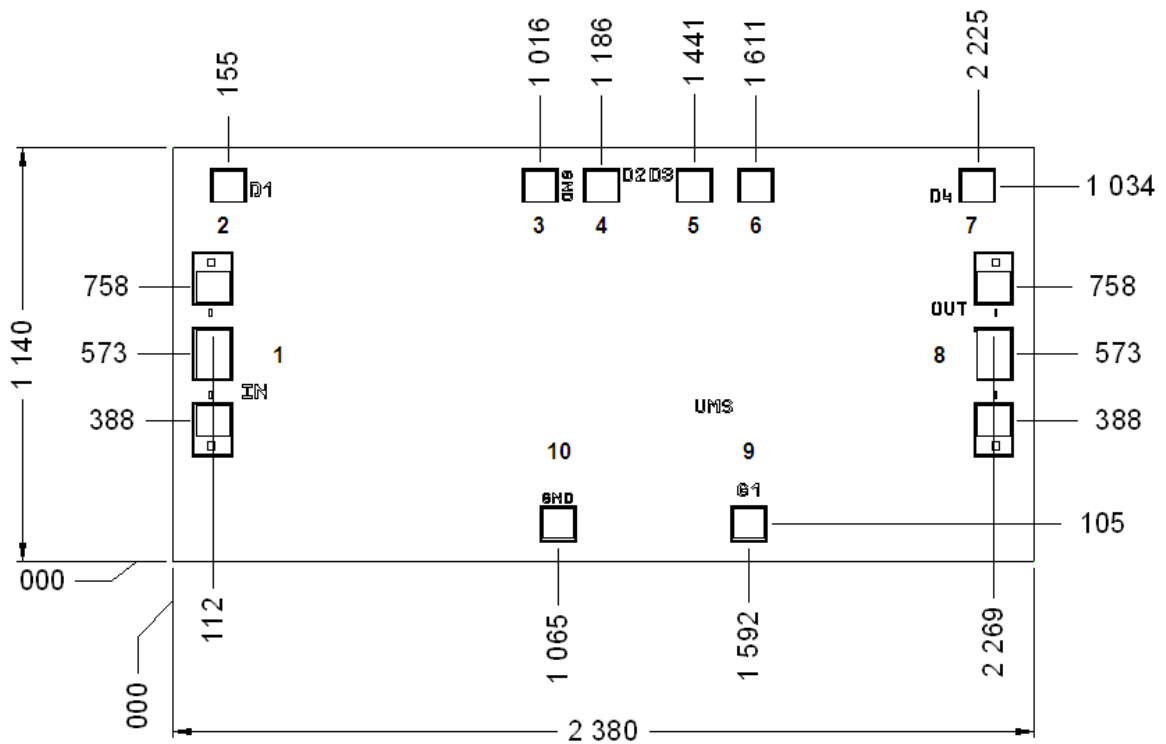

All dimensions are in micrometers

Chip size = 2380x1140 ±35µm

Chip thickness = 70µm ±10µm

RF pads (1, 8) = 110 x 150µm²

DC pads (2, 4, 5, 7, 9) = 100 x 100µm²

Chip width and length are given with a tolerance of ±35µm

| Pin number | Pin name | Description |
|------------|----------|-------------|
| 1 | IN | Input RF |
| 2 | D1 | Vd1 |
| 3, 6, 10 | GND | NC |
| 4 | D2 | Vd2 |
| 5 | D3 | Vd3 |
| 7 | D4 | Vd4 |
| 8 | OUT | Output RF |
| 9 | G1 | Vg |

Recommended assembly plan

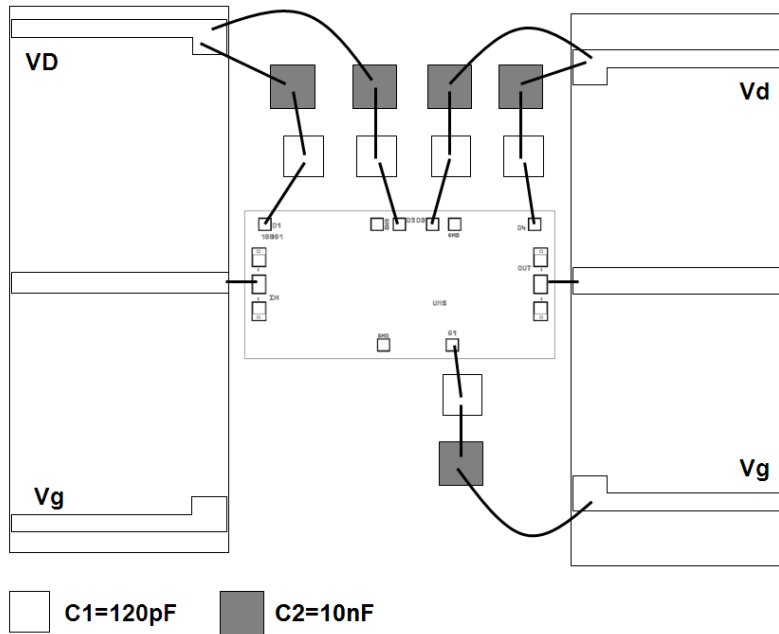

Bonding recommendations

| Port | Connection | External capacitor |
|------|--|-----------------------|
| IN | Inductance (L_{bonding}) = 0.3nH 400 μm length with a wire diameter of 25 μm | |
| OUT | Inductance (L_{bonding}) = 0.3nH 400 μm length with a wire diameter of 25 μm | |
| Vg | Inductance \leq 1nH | C1 ~ 120pF, C2 ~ 10nF |
| Vd | Inductance \leq 1nH | C1 ~ 120pF |

DC Schematic

Medium Power Amplifier: 6V, 230mA

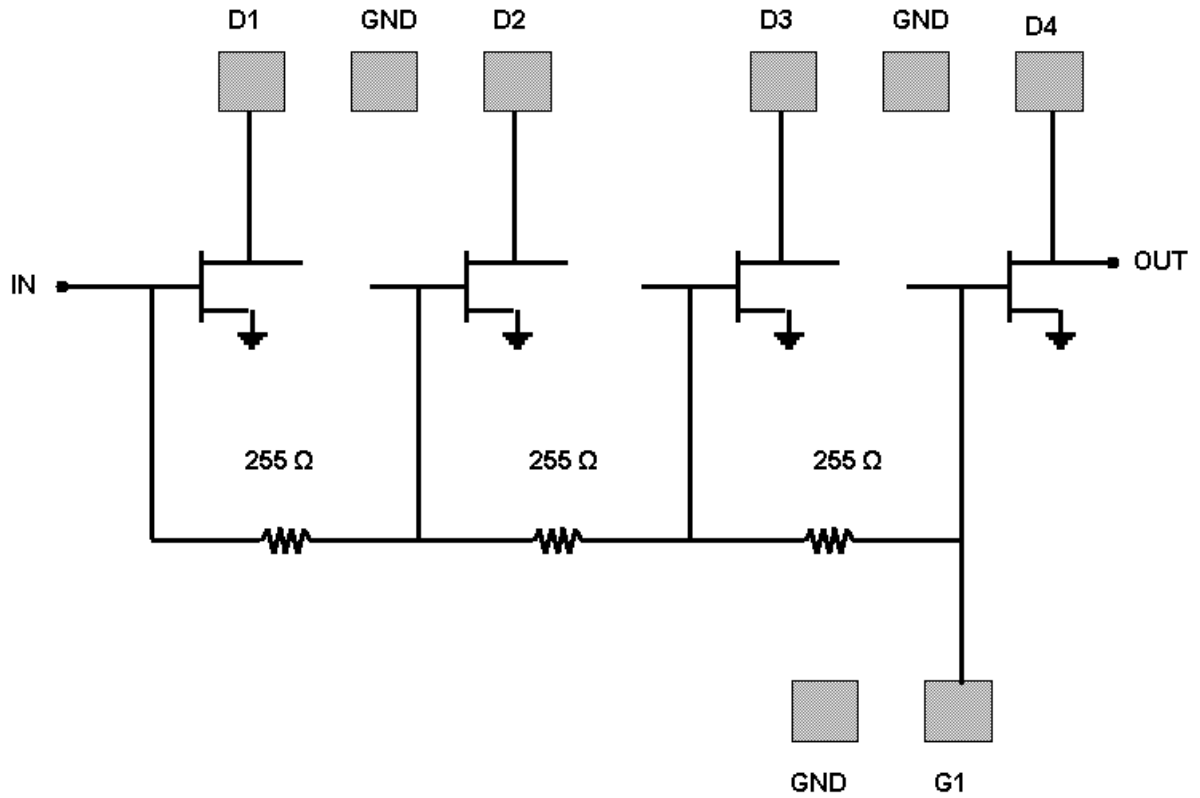

Recommended ESD management

Refer to the application note AN0020 available at <http://www.ums-gaas.com> for ESD sensitivity and handling recommendations for the UMS products.

Recommended environmental management

UMS products are compliant with the regulation in particular with the directives RoHS N°2011/65 and REACH N°1907/2006. More environmental data are available in the application note AN0019 also available at <http://www.ums-gaas.com>.

Ordering Information

Chip form:

CHA5050-99F/00

Information furnished is believed to be accurate and reliable. However **United Monolithic Semiconductors S.A.S.** assumes no responsibility for the consequences of use of such information nor for any infringement of patents or other rights of third parties which may result from its use. No license is granted by implication or otherwise under any patent or patent rights of **United Monolithic Semiconductors S.A.S.**. Specifications mentioned in this publication are subject to change without notice. This publication supersedes and replaces all information previously supplied. **United Monolithic Semiconductors S.A.S.** products are not authorised for use as critical components in life support devices or systems without express written approval from **United Monolithic Semiconductors S.A.S.**