

# X Band HBT Driver Amplifier

## GaAs Monolithic Microwave IC

### Description

The CHA5014 chip is a monolithic two-stage medium power amplifier designed for X band applications. Moreover this amplifier is relevant for systems that require an output power weakly sensitive to temperature.

This device is manufactured using a GaInP HBT process, including, via holes through the substrate and air bridges. A nitride layer protects the transistors and the passive components.

A special control circuit is implemented to stabilize the output power in temperature.

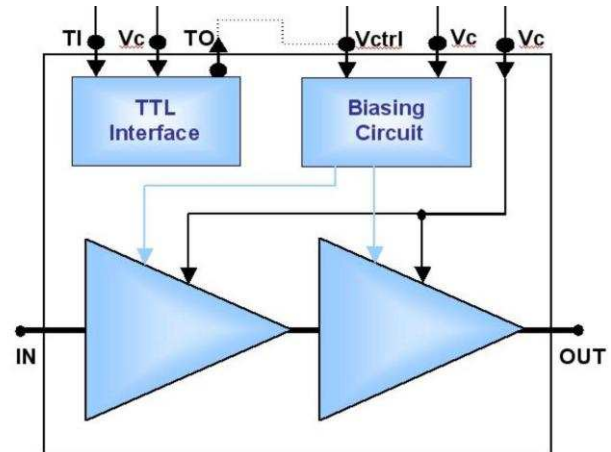

### Main Features

- 30dBm Saturated output power
- Temperature compensated Output power
- Two biasing modes:
  - Digital control thanks to TTL interface
  - Analog control thanks to Biasing circuit
- Quiescent bias point: 8.5V@230mA
- Chip size: 2.87 x 1.37 x 0.1mm<sup>3</sup>

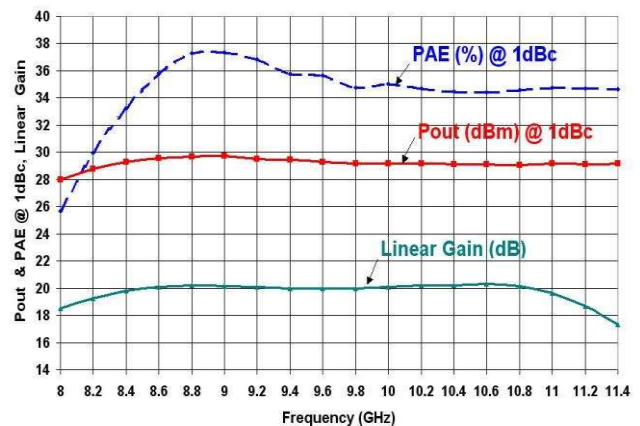

Pout & PAE @ 1dBc and Linear Gain (Tamb 20 °C)

### Main Characteristics

Tamb = +20 °C, Vc = +8.5V (Pulse 100µs 20%)

Symbol	Parameter	Min	Typ	Max	Unit
Fop	Operating frequency range	8.5		11	GHz
G	Small signal gain		20		dB
P1dB	Output power at 1dB gain compression		29		dBm
Icq	Power supply quiescent current		230		mA

ESD Protections: Electrostatic discharge sensitive device observe handling precautions!

## Electrical Characteristics

Vc = +8.5V (Pulse 100µs 20%)

Symbol	Parameter	Min	Typ	Max	Unit
Top	Operating temperature range	-40		80	°C
Fop	Operating frequency range	8.5		11	GHz
G	Small signal gain at 20°C		20		dB
ΔG	Small signal gain flatness at 20°C		±0.25		dB
ΔG_T	Linear gain variation vs temperature		-0.03		dB/°C
P1dB	Output power at 1dB gain compression		29		dBm
Psat	Saturated output power		30		dBm
PAE_1dBc	PAe at 1dB gain compression at 20°C		35		%
dBS11	Input Return Loss		-12		dB
dBS22	Output Return Loss		-12		dB
Vc	Power supply voltage		8.5		V
Icq	Power supply quiescent current (1)		230		mA
Ic_1dBc	Consumption under 1dB gain compression		260		mA
Vctrl	Collector current control voltage		5		V
Ictrl	Biasing circuit consumption		5		mA
TI_Low	TTL input voltage low level	0		0.4	V
TI_High	TTL input voltage high level (1)	2.5		7.0	V
I_TI	TTL input current		1		mA

(1) For Vc = 8.5V, TTL interface settles Icq to 230mA when TI=TI\_High. If needed, Icq can be tuned thanks to Vctrl if the analog biasing circuit is used.

## Absolute Maximum Ratings (2)

Tamb = 20°C

Symbol	Parameter	Values	Unit
Cmp	Compression level (3)	6	dB
Vc	Power supply voltage (4)	10	V
Icq	Power supply quiescent current	320	mA
Ic_sat	Power supply current in saturation	370	mA
Vctrl	Collector current control voltage	6	V
Ai	CTRL voltage (TI_low, TI_high)	-2 , +8	V
Tj	Maximum Junction temperature (5)	175	°C
Tstg	Storage temperature range	-55 to +150	°C

- (2) Operation of this device above anyone of these parameters may cause permanent damage.
- (3) For higher compression the level limit can be increased by decreasing the voltage Vc using the rate 0.5V/dBc. Compression level shall not be higher than 3dB at -40°C.
- (4) Without RF input power
- (5) Equivalent Thermal Resistance to Backside : 45°C/W

**Typical measurement characteristics**

Tamb = 20°C, Vc = 8.5V, Ic (Quiescent) = 230mA Pulse = 100µs 20%

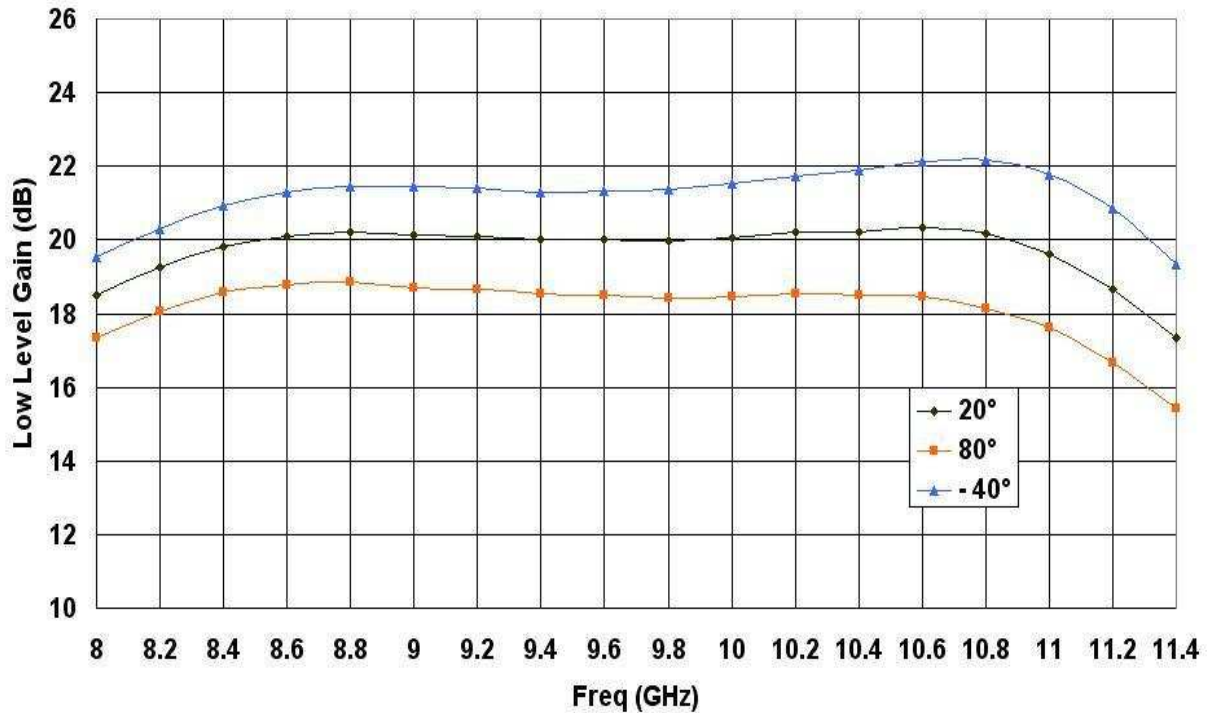

*Linear gain versus frequency and temperature*

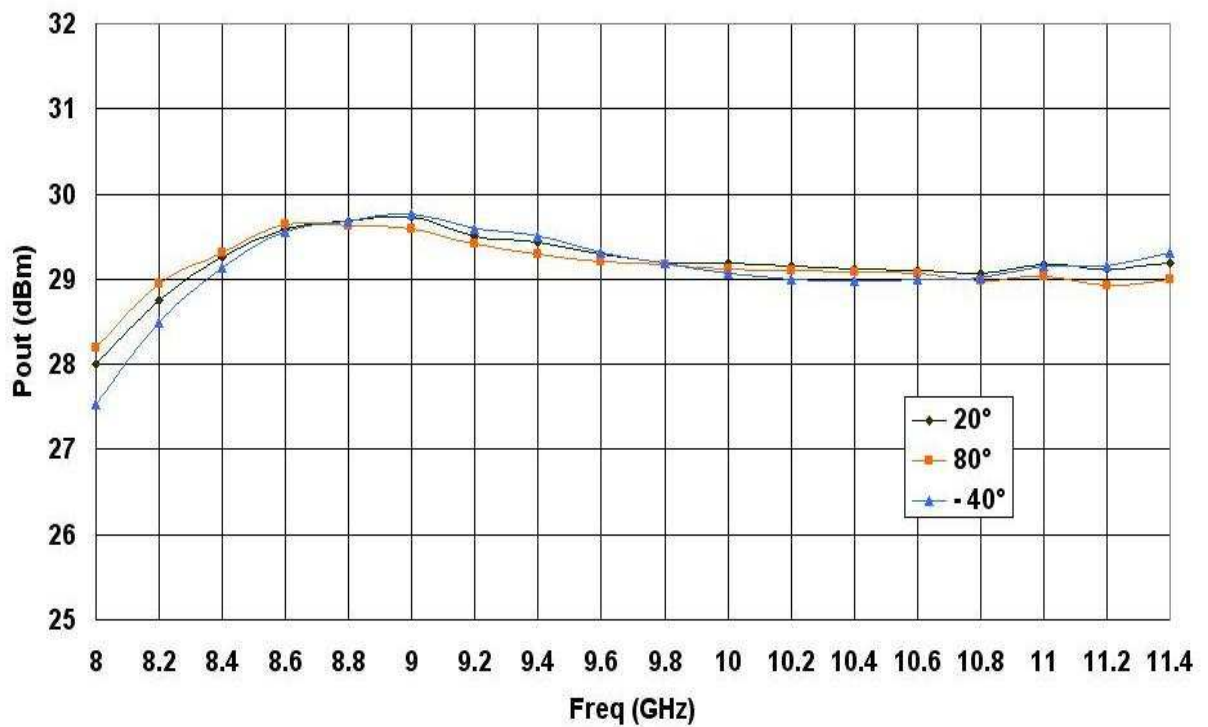

*Output Power @ 1dB gain compression versus frequency and temperature*

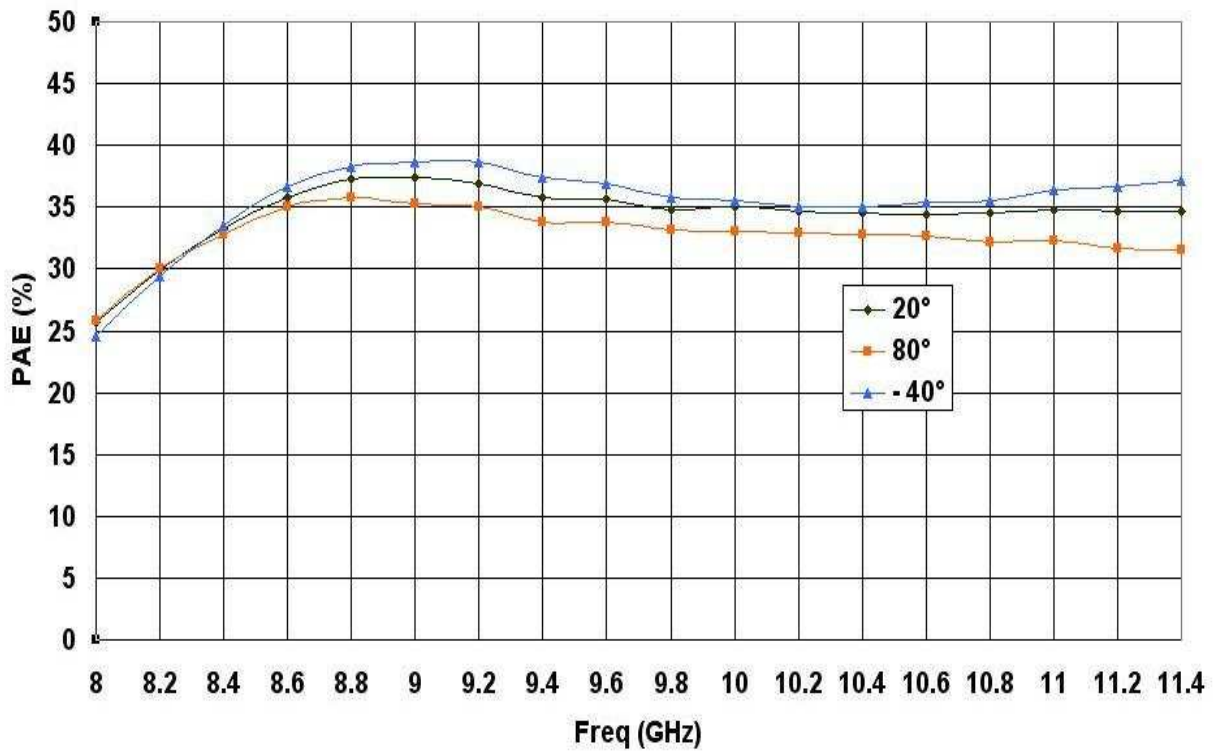

*Power added efficiency@1dB gain compression versus frequency*

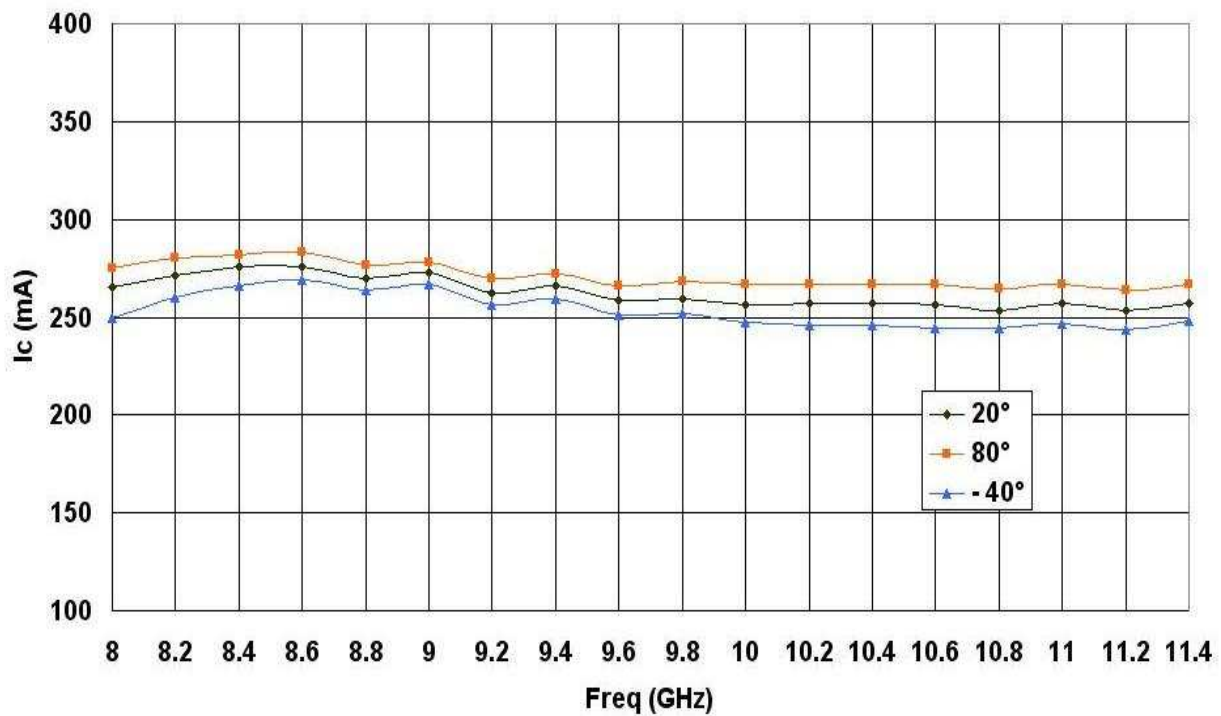

*Collector current @1dB gain compression versus frequency*

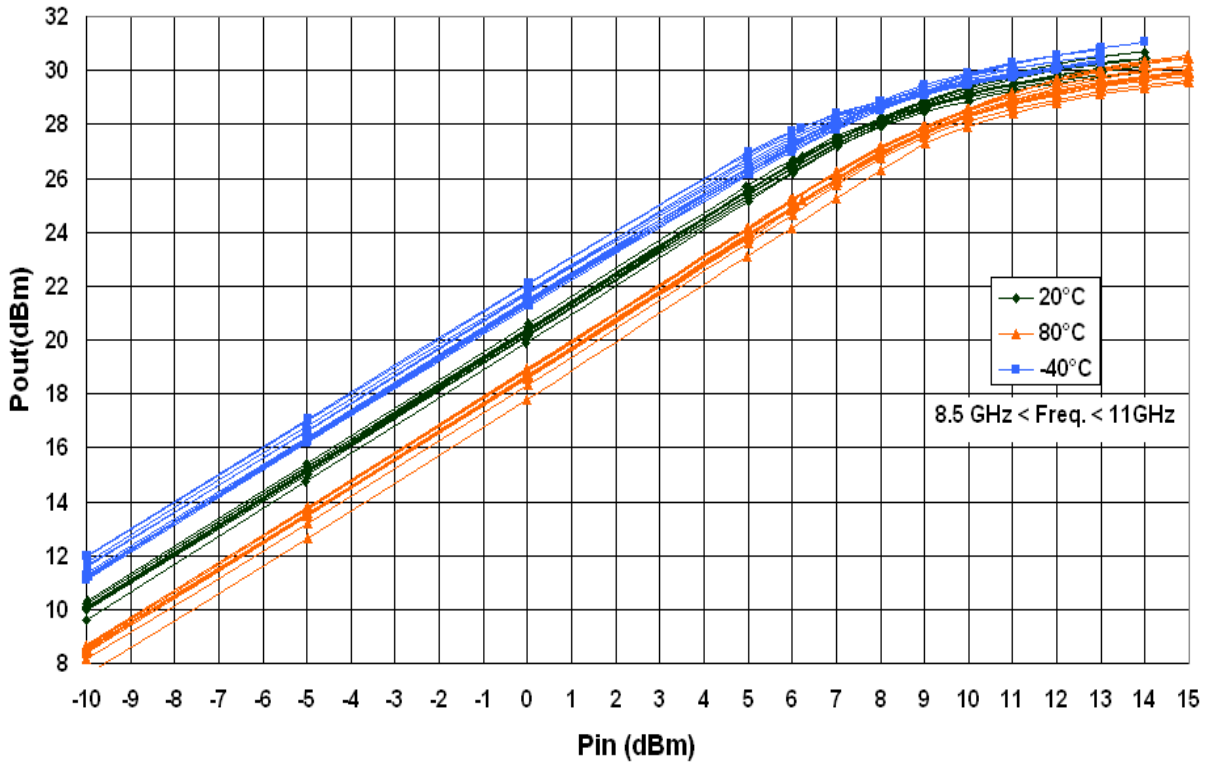

Output power versus Input power

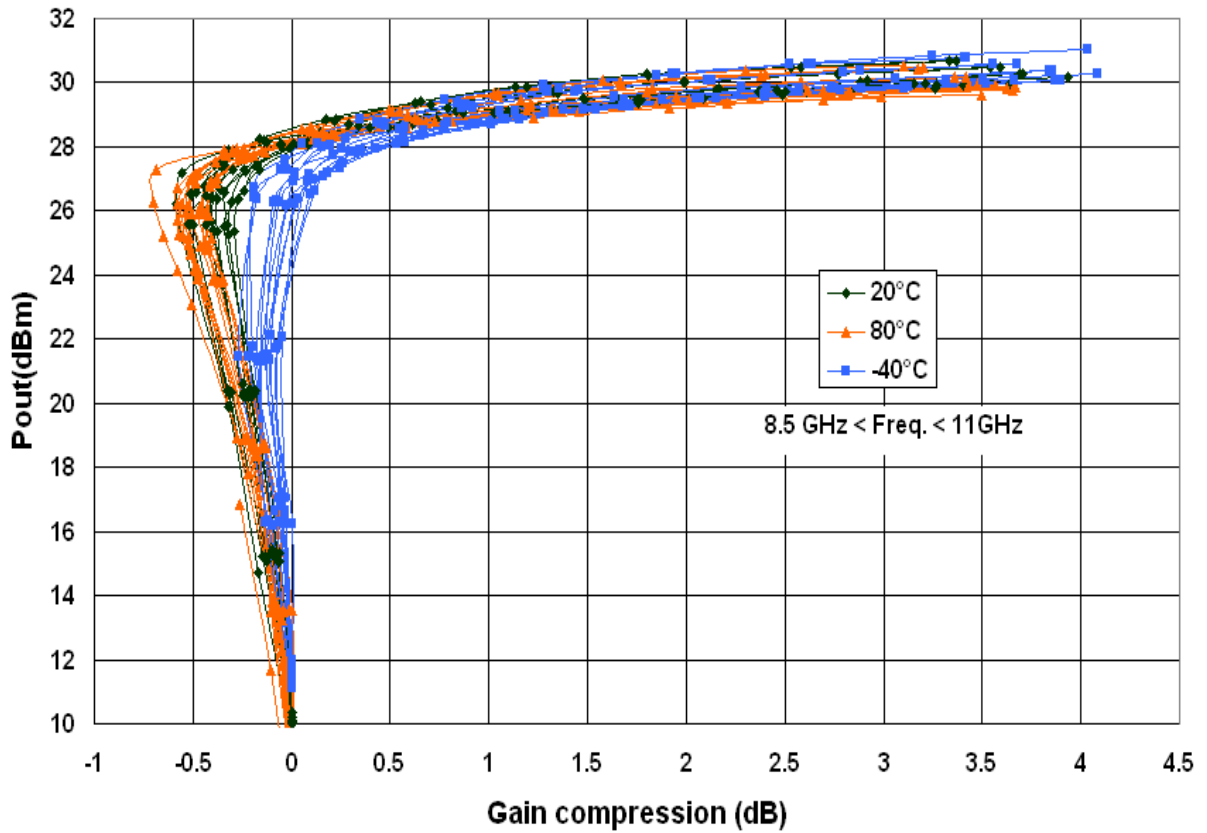

Output power versus gain compression

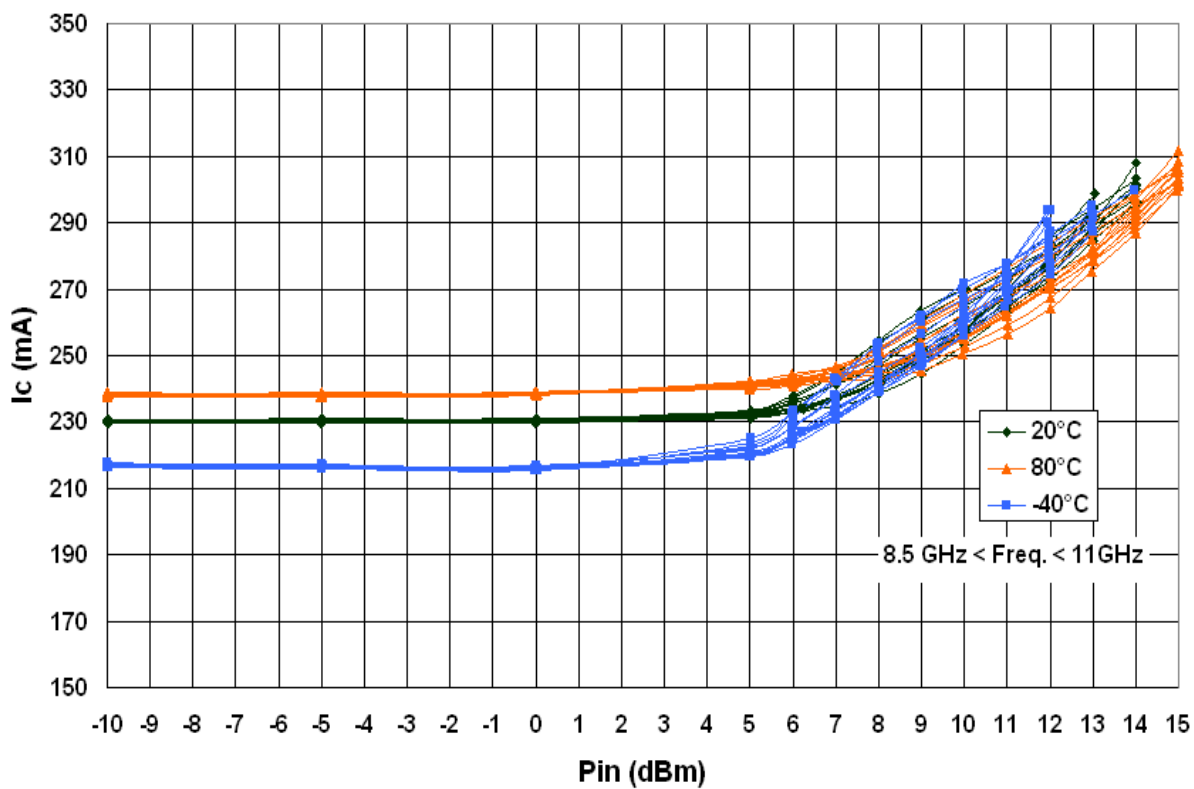

*Collector current versus Input power*

Chip Mechanical Data and Pin references

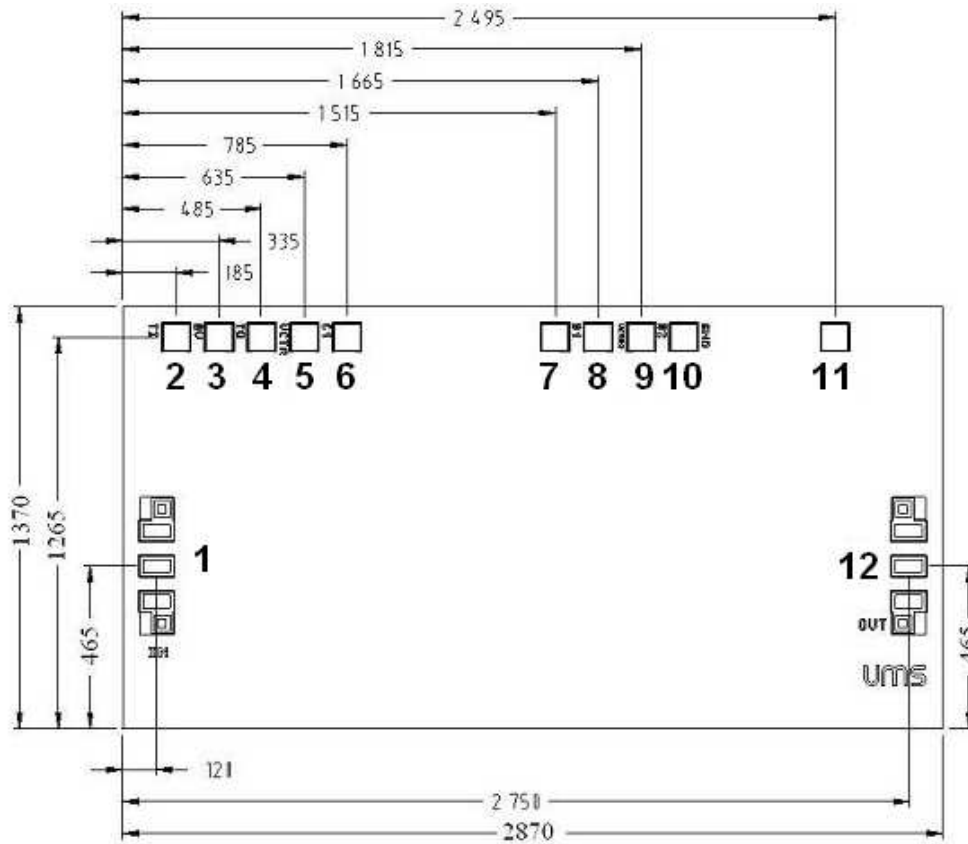

UNITS :  $\mu\text{m}$   
Tol :  $\pm 35\mu\text{m}$

Chip thickness =  $100 \pm 10\mu\text{m}$   
RF pads (1, 12) =  $118 \times 68\mu\text{m}^2$   
DC pads (2, 3, 4, 5, 9, 6, 7, 8, 9, 10, 11) =  $96 \times 96\mu\text{m}^2$

Pin number	Pin name	Description
1	IN	Input RF port
7, 9		NC
5, 8	Vctrl	Collector current control voltage
2	TI	TTL input
4	TO	TTL output
10	GND	Ground (NC)
3, 6, 11	Vc	Power supply voltage
12	OUT	Output RF port

Recommended ESD management

Refer to the application note AN0020 available at <http://www.ums-gaas.com> for ESD sensitivity and handling recommendations for the UMS products.

## Assembly recommendations in test fixture (TTL interface)

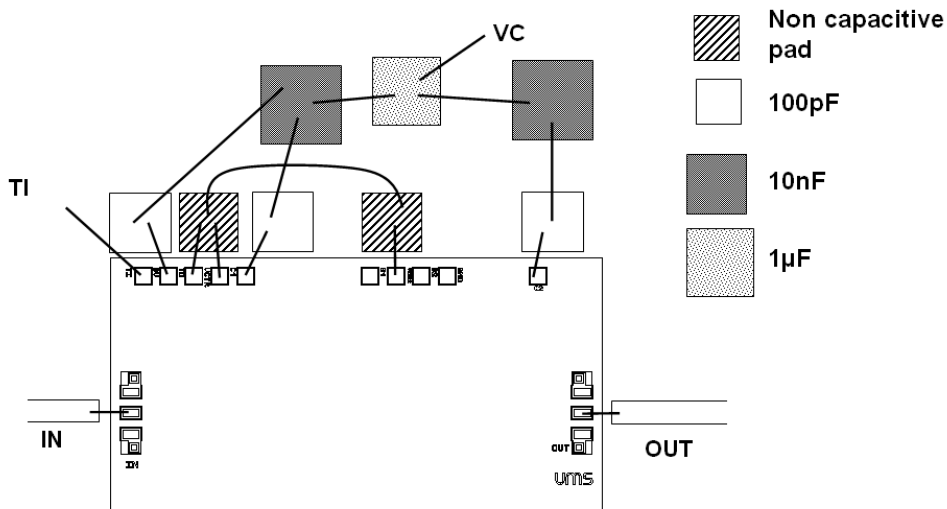

Note: when the TTL interface is used for biasing, the pin TO (pin number 4) must be connected to the pins Vctrl (pins number 5 and 8).

## Assembly recommendations in test fixture (using Biasing circuits)

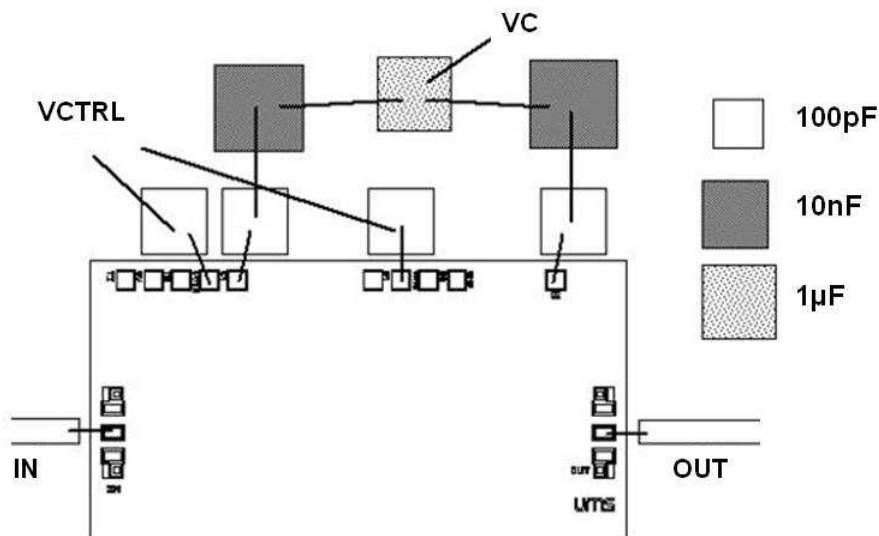

## Ordering Information

Chip form : CHA5014-99F/00

Information furnished is believed to be accurate and reliable. However **United Monolithic Semiconductors S.A.S.** assumes no responsibility for the consequences of use of such information nor for any infringement of patents or other rights of third parties which may result from its use. No license is granted by implication or otherwise under any patent or patent rights of **United Monolithic Semiconductors S.A.S.** Specifications mentioned in this publication are subject to change without notice. This publication supersedes and replaces all information previously supplied. **United Monolithic Semiconductors S.A.S.** products are not authorised for use as critical components in life support devices or systems without express written approval from **United Monolithic Semiconductors S.A.S.**