

## 1-18 GHz WIDE BAND AMPLIFIER GaAs Monolithic Microwave IC

### Description

The CHA3023 is a travelling wave amplifier using cascode FET. It is designed for a wide range of applications.

The circuit is manufactured with a pHEMT process of 0.25µm gate length, via holes through the substrate and air bridges and it is available in die form.

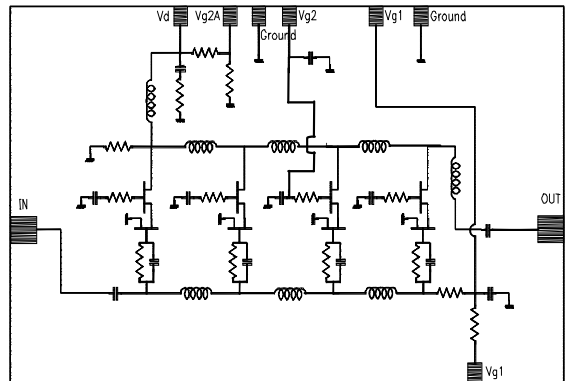

### Main Features

- Broadband performances: 1-18 GHz
- 14dB gain
- 3dB typical Low Noise Figure
- ± 0.7 dB gain flatness
- Chip size: 2.15 X 1.42 X 0.10mm

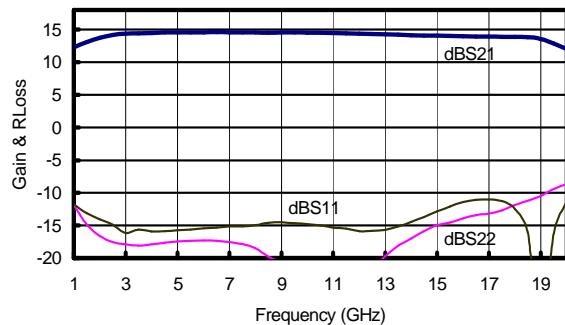

On wafer measurements

### Main Characteristics

Tamb. = 25°C

Symbol	Parameter	Min	Typ	Max	Unit
Fop	Operating frequency range	1		18	GHz
G	Small signal Gain	12.5	14		
NF	Noise figure			4	dB
Id	Bias current		95		mA

ESD Protection : Electrostatic discharge sensitive device. Observe handling precautions !

## Electrical Characteristics for Broadband Operation

Tamb = +25°C,

Vd=5V, Vg1=-0.3V tuned to have Id=95mA Vg2=+2V

Symbol	Parameter	Min	Typ	Max	Unit
Fop	Operating frequency range	1		18	GHz
G	Small signal gain F= 1 to 3GHz F= 3 to 18GHz	11.5 12.5	13 14		dB dB
ΔG	Small signal gain flatness		± 0.7		dB
P1dB	Output power at 1dB gain compression	15	17		dBm
VSWRin	Input VSWR		2.2:1		
VSWRout	Output VSWR		2.2:1		
NF	Noise Figure F= 1 to 4GHz F= 1 to 18GHz		4 2.5	6 4	dB dB
Vdc	DC voltage Vd Vg1 Vg2		+5 -0.3 +2		V V V
Id	Bias current		95		mA

## Absolute Maximum Ratings

Tamb. = 25°C (1)

Symbol	Parameter	Min.	Max.	Unit
Vd	Drain to ground bias voltage	0	6.5	V
Id	Drain current		110	mA
Vg1	Gate to ground bias voltage	-1.5	0.3	V
Vg2	Gate to ground bias voltage	0	3	V
Pin	Maximum peak input power overdrive (2)		+15	dBm
Pin	Maximum input CW power		+10	dBm
Top	Operating temperature	-40	85	°C
Tstg	Storage temperature range	-55	125	°C

(1) Operation of this device above anyone of these parameters may cause permanent damage

(2) Duration < 1s

## Typical Results

### Chip Typical Response (On wafer Sij)

Tamb = +25°C

Vd = 5.0V ; Vg2 = 2V and Vg1 tuned to Id = 95mA

Freq GHz	MS11 dB	PS11 °	MS12 dB	PS12 °	MS21 dB	PS21 °	MS22 dB	PS22 °
1,00	-11,84	-86,69	-68,86	12,95	12,27	175,21	-11,75	175,50
1,50	-14,88	-96,63	-59,00	-65,50	13,11	164,60	-13,13	134,72
2,00	-16,59	-102,61	-57,76	-85,24	13,74	152,90	-14,05	103,57
2,50	-17,55	-106,89	-55,88	-101,83	14,21	140,45	-14,93	77,53
3,00	-17,90	-110,67	-56,09	-133,36	14,38	127,54	-16,15	60,98
3,50	-18,04	-114,80	-54,51	-146,60	14,42	116,64	-15,59	48,79
4,00	-17,90	-119,10	-53,45	-166,51	14,50	105,01	-15,88	36,69
4,50	-17,64	-124,04	-52,07	178,88	14,55	93,81	-15,86	24,61
5,00	-17,43	-129,21	-52,57	165,06	14,56	82,83	-15,73	15,78
5,50	-17,36	-134,92	-50,96	155,03	14,57	71,87	-15,62	6,63
6,00	-17,32	-140,65	-49,52	145,22	14,57	61,00	-15,45	-1,24
6,50	-17,35	-146,35	-48,93	131,37	14,59	50,26	-15,32	-9,98
7,00	-17,55	-152,20	-48,40	115,97	14,58	39,44	-15,18	-16,89
7,50	-17,83	-157,72	-47,52	106,26	14,57	28,65	-15,15	-23,44
8,00	-18,45	-162,53	-46,94	95,20	14,56	17,95	-14,94	-30,10
8,50	-19,80	-164,62	-46,12	84,24	14,54	7,35	-14,56	-35,12
9,00	-20,69	-168,37	-45,55	74,79	14,55	-3,41	-14,48	-41,40
9,50	-21,89	-169,76	-44,84	62,64	14,55	-14,27	-14,67	-46,03
10,00	-23,72	-166,34	-44,04	53,09	14,53	-25,14	-14,80	-51,30
10,50	-25,53	-158,58	-43,80	39,38	14,50	-36,02	-14,99	-53,99
11,00	-26,70	-141,85	-43,12	26,47	14,48	-46,99	-15,32	-57,64
11,50	-25,89	-122,93	-42,27	14,98	14,44	-57,87	-15,48	-58,42
12,00	-24,09	-110,31	-41,97	2,10	14,40	-68,96	-15,87	-59,30
12,50	-21,74	-106,76	-41,35	-12,13	14,35	-79,91	-15,80	-58,07
13,00	-19,70	-104,76	-41,15	-24,23	14,29	-90,92	-15,65	-56,60
13,50	-18,11	-106,18	-40,87	-38,14	14,23	-101,96	-15,16	-55,31
14,00	-17,00	-112,34	-40,38	-49,23	14,17	-112,98	-14,47	-55,03
14,50	-15,86	-116,67	-40,14	-64,35	14,11	-124,02	-13,71	-56,11
15,00	-14,97	-120,58	-39,83	-75,76	14,05	-135,10	-12,85	-58,60
15,50	-14,53	-124,94	-39,66	-88,72	14,01	-146,32	-12,09	-63,04
16,00	-13,93	-128,81	-39,29	-102,25	13,97	-157,55	-11,44	-69,64
16,50	-13,43	-132,05	-38,83	-118,12	13,93	-168,97	-11,06	-77,10
17,00	-13,18	-134,80	-38,87	-127,14	13,92	179,41	-11,02	-85,48
17,50	-12,67	-137,46	-38,86	-144,06	13,92	167,15	-11,28	-95,81
18,00	-11,85	-137,37	-37,71	-156,10	13,91	154,49	-12,47	-109,17
18,50	-11,23	-139,77	-37,48	-170,79	13,84	140,84	-16,01	-125,94
19,00	-10,46	-143,04	-37,24	175,70	13,57	125,81	-32,15	-109,28
19,50	-9,39	-147,86	-36,76	157,84	12,86	111,51	-16,15	-15,25
20,00	-8,65	-153,32	-36,48	142,87	12,02	99,83	-11,25	-34,96

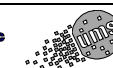

## Chip Typical Response (On wafer measurements)

Tamb = +25°C

Vd = 5.0V ; Vg2 = 2V and Vg1 tuned to Id = 95mA

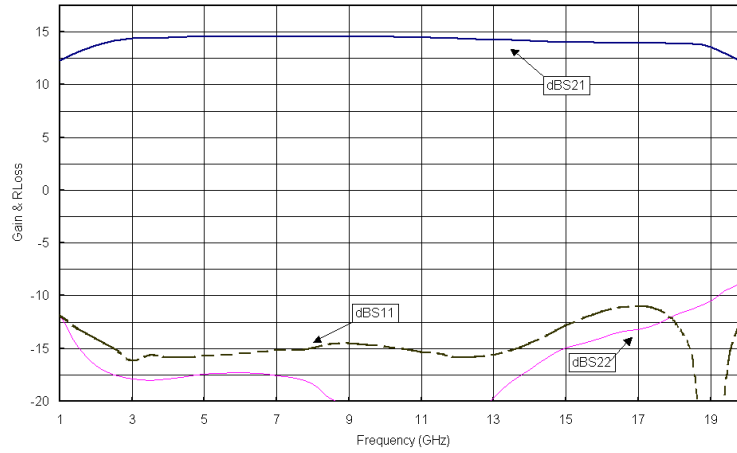

Typical on wafer S parameters

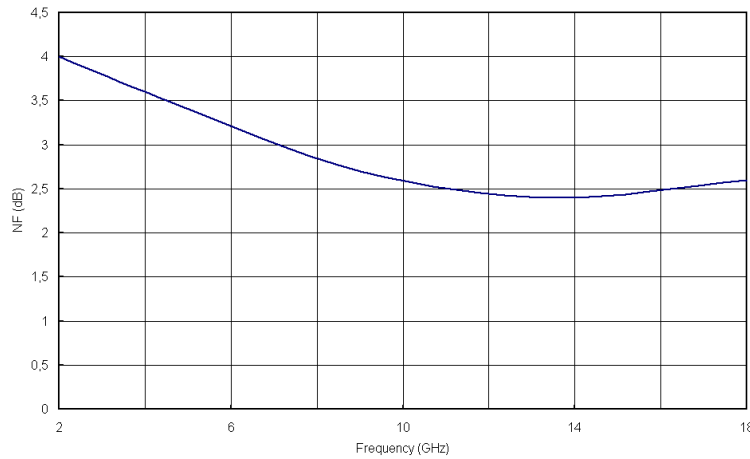

Typical on wafer Noise Figure

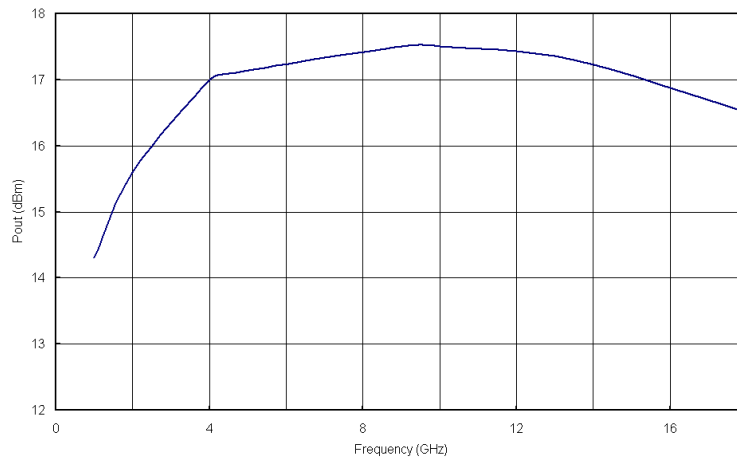

Pout vs Frequency (Pin=4dBm)

**Chip Typical Response (Test Jig measurements)**

Tamb = +25°C

Vd = 5.0V ; Vg2 = 2V and Vg1 tuned to Id = 95mA

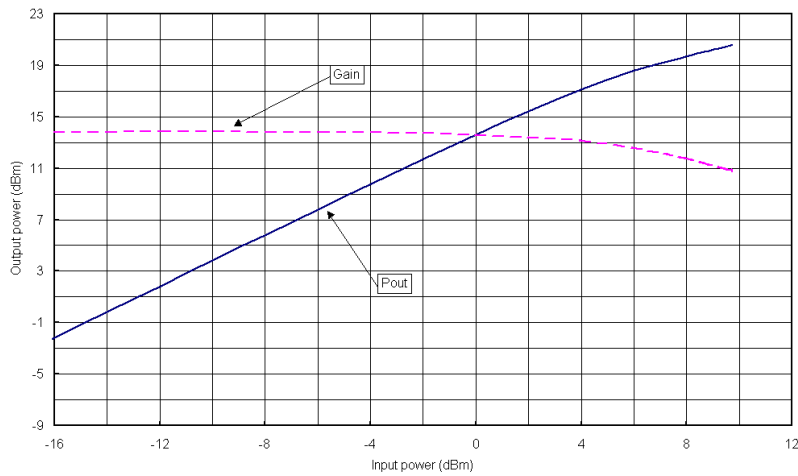

**Power compression @ 1GHz**

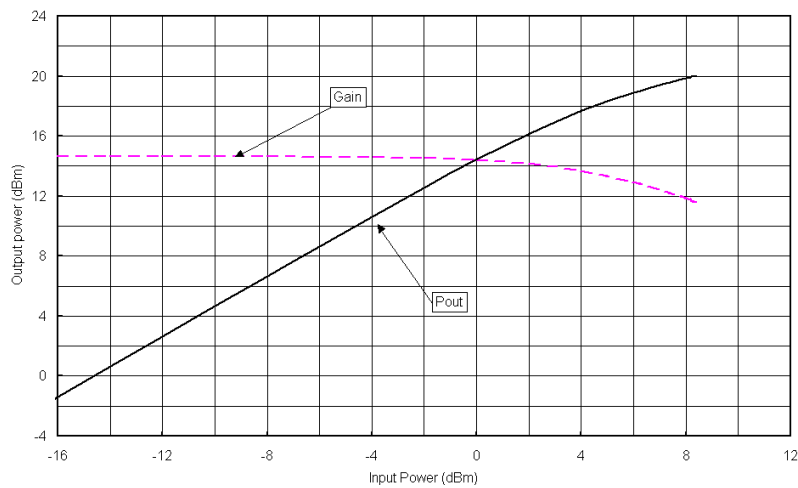

**Power compression @ 12GHz**

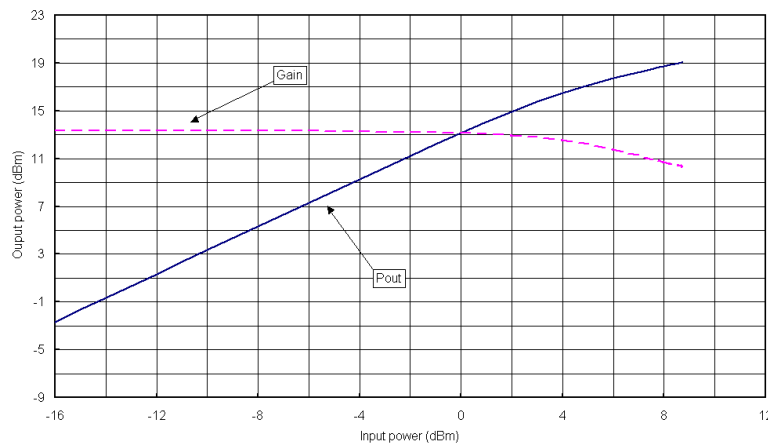

**Power compression @ 18GHz**

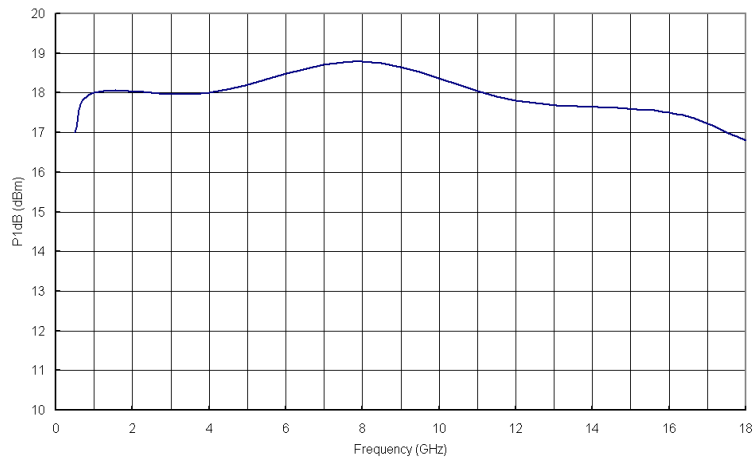

**P1dB vs Frequency**

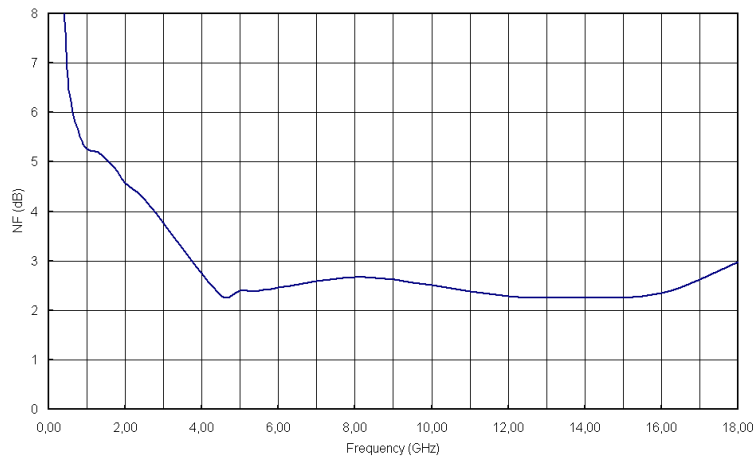

**Noise Figure vs Frequency**

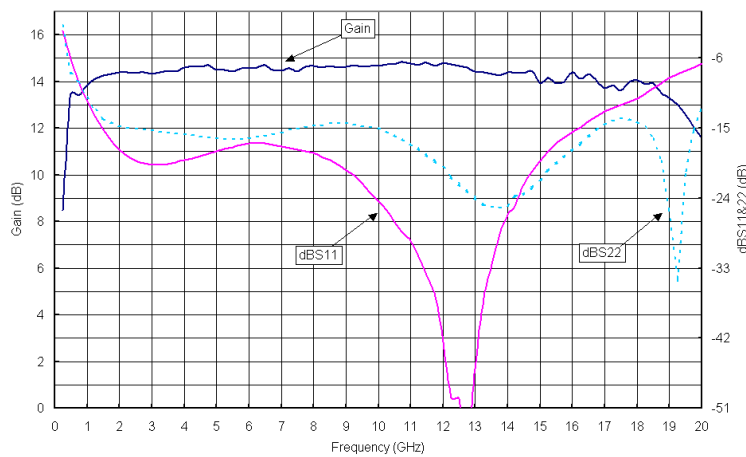

**Gain & Return Loss vs Frequency**



**Bonding pad positions**

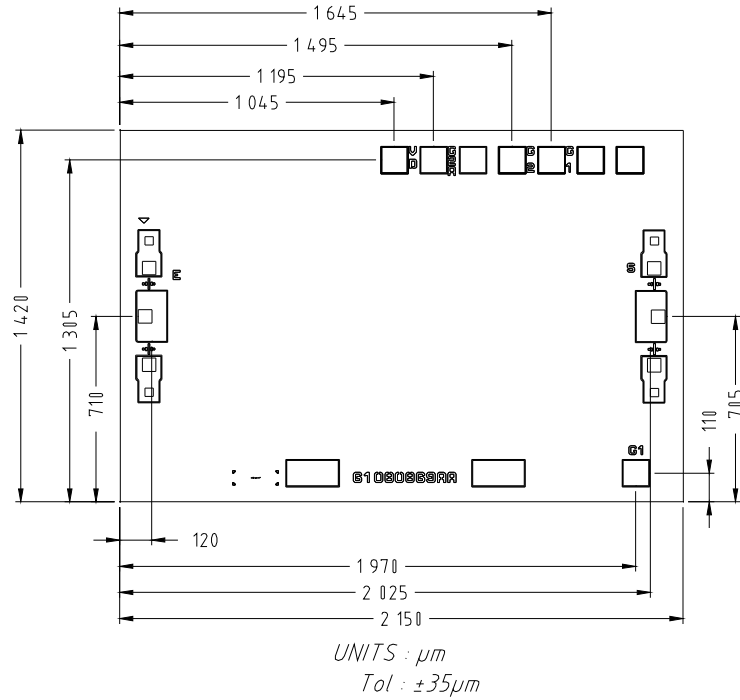

Chip Thickness: 100um  
Chipsize: 2150X1420±35 μm

**Ordering Information**

Chip form : CHA3023-99F/00

Information furnished is believed to be accurate and reliable. However **United Monolithic Semiconductors S.A.S.** assumes no responsibility for the consequences of use of such information nor for any infringement of patents or other rights of third parties which may result from its use. No license is granted by implication or otherwise under any patent or patent rights of **United Monolithic Semiconductors S.A.S.** Specifications mentioned in this publication are subject to change without notice. This publication supersedes and replaces all information previously supplied. **United Monolithic Semiconductors S.A.S.** products are not authorised for use as critical components in life support devices or systems without express written approval from **United Monolithic Semiconductors S.A.S.**