

5-6GHz 6-bit Phase-Shifter

GaAs Monolithic Microwave IC

Description

The CHP4014-98F is a 6-bit digital phase shifter MMIC with a 0°-360° range. It is designed for 5 to 6GHz frequency range applications. The circuit supports a variety of C-band phased array applications including industrial sensors and military radars. The circuit is manufactured with a Power pHEMT process, 0.25µm gate length.

It is available in chip form.

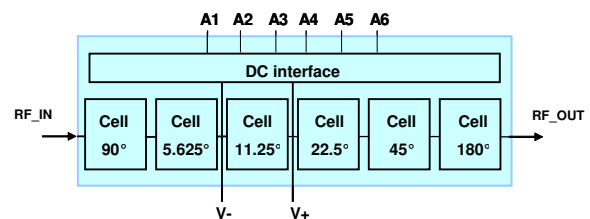

Main Features

- Broadband performances: 5-6GHz
- 5.625° phase step
- 6dB Losses
- 26dBm input power at -1dB comp.
- I/O reversible
- TTL compatible control inputs
- chip size 3.54x2.54x0.1mm

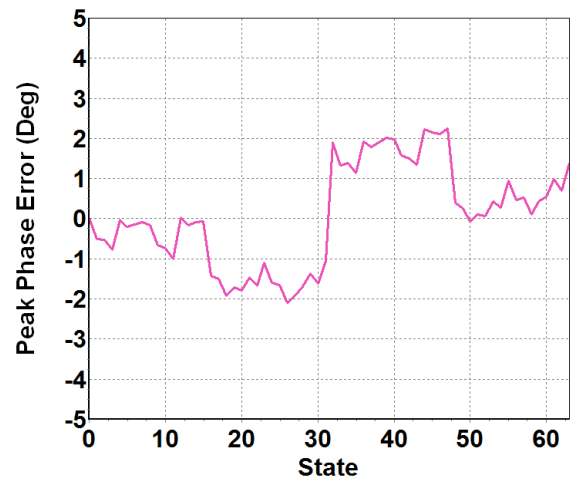

Peak Phase Error versus state @ 5.5GHz
(wafer measurement)

Main Characteristics

Tamb.= +25°C

Symbol	Parameter	Min	Typ	Max	Unit
Fop	Operating frequency range	5		6	GHz
Ls	Insertion loss		6	7	dB
P1dB	Input power at 1dB compression		26		dBm
VA _i ⁽¹⁾	Voltage control	0	3.3	7	V

⁽¹⁾ i=1, 2, 3, 4, 5, and 6

ESD Protection: Electrostatic discharge sensitive device. Observe handling precautions!

Main Characteristics

Tamb.= +25°C

Symbol	Parameter	Min	Typ	Max	Unit
Fop	Operating frequency range	5		6	GHz
PhS	Phase Shifting Range	0		360	deg
PhS step	Phase Shifting Step		5.625		deg
PPE	Peak Phase Error		+/- 4	+/- 7	deg
RMSPE_Std	RMS Phase Error Standard Deviation		1	2	deg
RMSPE	RMS Phase Error		1	2	deg
Ls	Insertion Loss		6	7	dB
LsV	Insertion Loss variation		+/- 0.4	+/- 0.7	dB
RL_In	Input Return Loss	-10	-17		dB
RL_Out	Output Return Loss	-12	-20		dB
P1dB	Input power at 1dB compression (CW)		26		dBm
IIP3	Input Third Order Intercept		32		dBm
Ts	Switching time		20	50	ns
V_low	Control Input (A1-A6) – low level	0		0.4	V
V_high	Control Input (A1-A6) – high level	2.4	3.3	7	V
V+	Positive Supply Voltage		5		V
V-	Negative Supply Voltage		- 5		V
I+	Positive Supply Current		3.5	10	mA
I-	Negative Supply Current		3.5	10	mA
Top	Operating temperature	-40		+85	deg

Absolute Maximum Ratings ⁽¹⁾

Tamb.= +25°C

Symbol	Parameter	Values	Unit
V+	Maximum DC positive supply voltage	+8	V
V-	Maximum DC negative supply voltage	-8	V
Ai ⁽²⁾	Phase Shifter CTRL voltage (V_low, V_high)	-2 , +8	V
Pin	Maximum peak input power overdrive	+30	dBm
Top	Operating temperature range	-40 to +85	°C
Tstg	Storage temperature range	-55 to +150	°C

⁽¹⁾ Operation of this device above any one of these parameters may cause permanent damage.

⁽²⁾ i= (1, 2, 3, 4, 5, and 6)

Peak Phase Error (PPE) definition

$$PPE_{(i)} = \text{measured_phase}(S21)_{(i)} - \text{measured_phase}(S21)_{(0)} - \text{theoretical_phase}_{(i)}$$

where (i) is the state (from 0 to 63)

RMS Phase Error (RMSPE) definition

$$RMS_PE = \sqrt{\frac{\sum_{i=0}^{63} PPE^2(i)}{64}}$$

Where i is the state number (from 0 to 63).

Insertion Losses Variation (LsV) definition

$$LsV_{(i)} = \text{measured_dB}(S21)_{(i)} - \text{measured_dB}(S21)_{(0)}$$

where (i) is the state (from 0 to 63)

Typical on-wafer results with 0.3nH inductance on input and output [S] parameters

Tamb.= +25°C; V+=+5V; V=- -5V

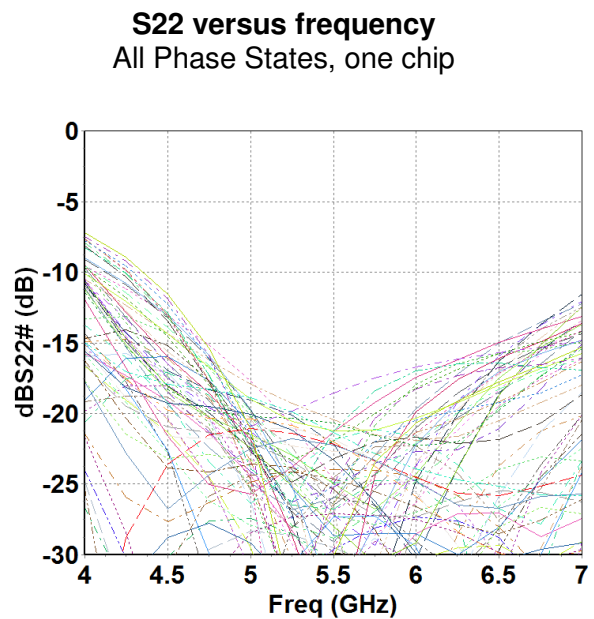
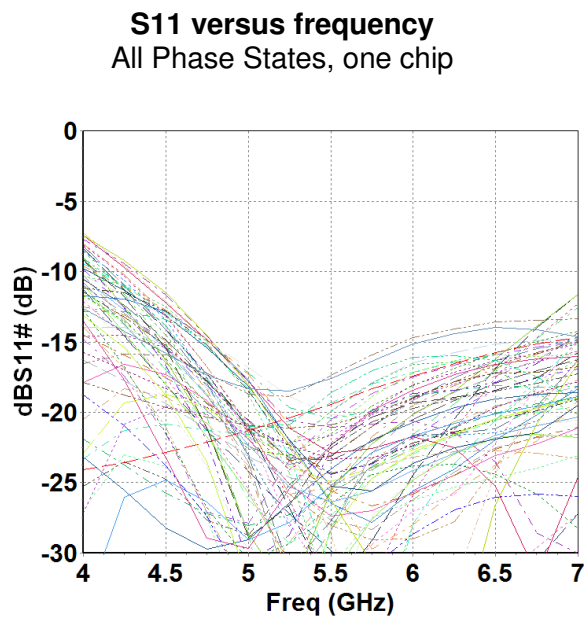
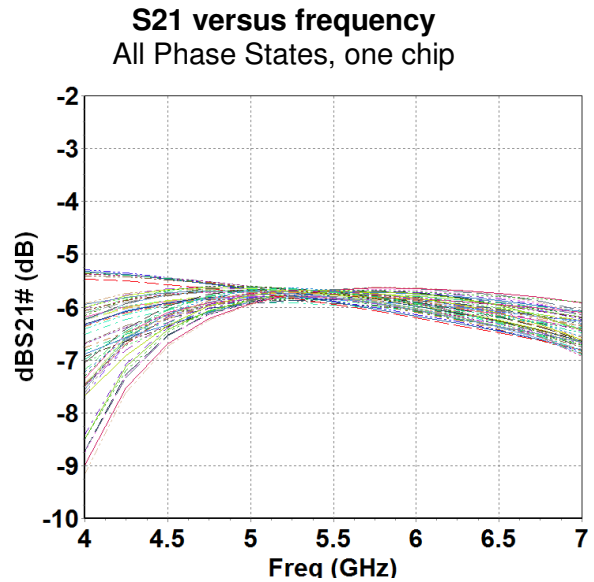
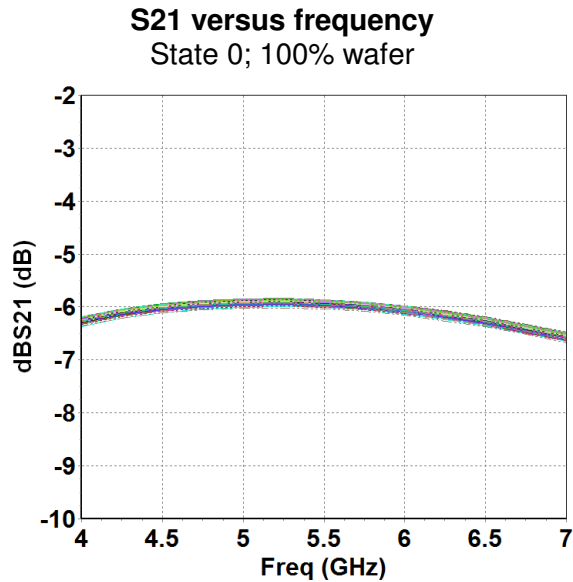

Typical on-wafer results

Phase shifter performances: Peak phase error

Tamb.= +25 °C; V+=+5V; V-= -5V

Peak phase error (deg) versus frequency
All Phase States, one chip

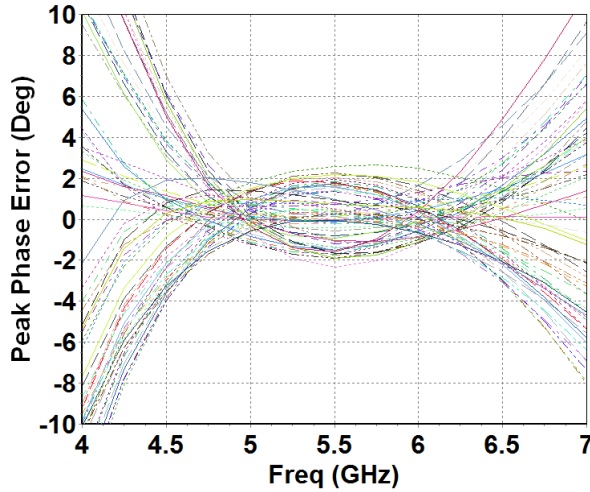

Peak phase error (deg) versus Phase State
State

Frequency = [5 – 6GHz], one chip

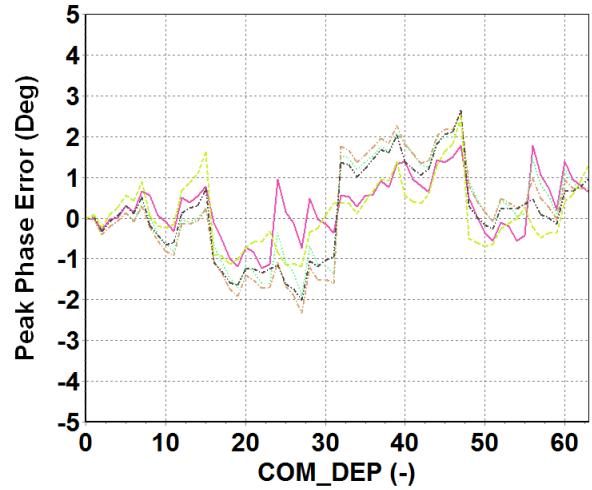

RMS Phase error

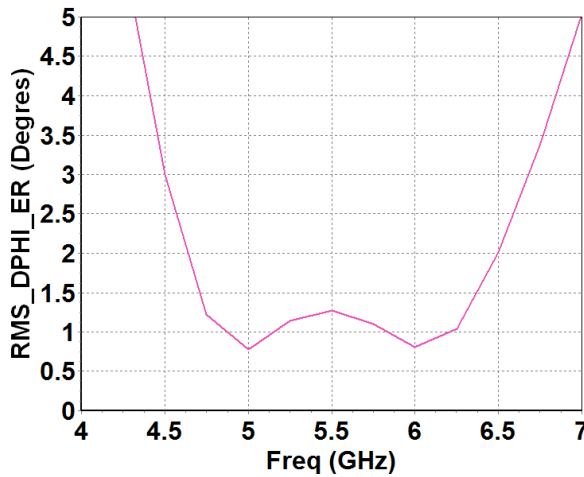

Peak phase (deg) versus Phase state

Frequency = [5 – 6GHz], one chip

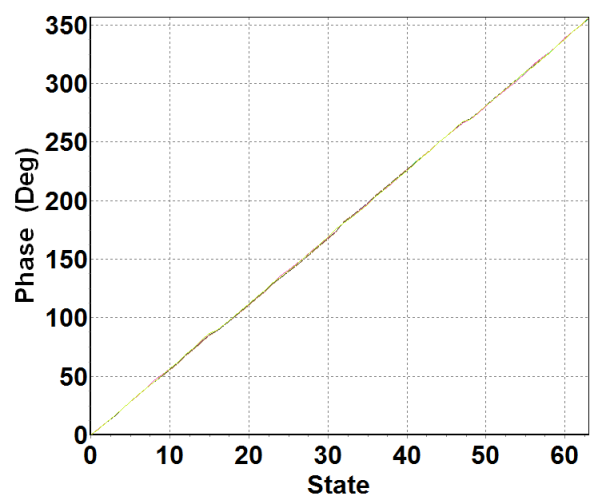

Typical on-wafer results

Phase shifter performances: Insertion loss variation

Tamb.= +25°C; V+=+5V; V=- -5V

Insertion loss variation (dB) versus frequency
All Phase States, one chip

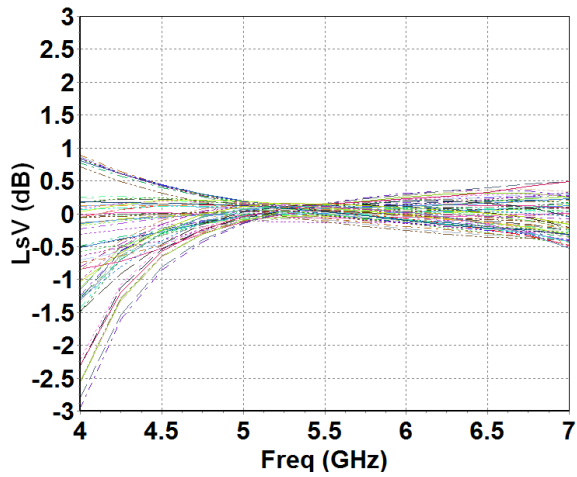

Insertion loss variation (dB) versus Phase State
Frequency = [5 - 6GHz], one chip

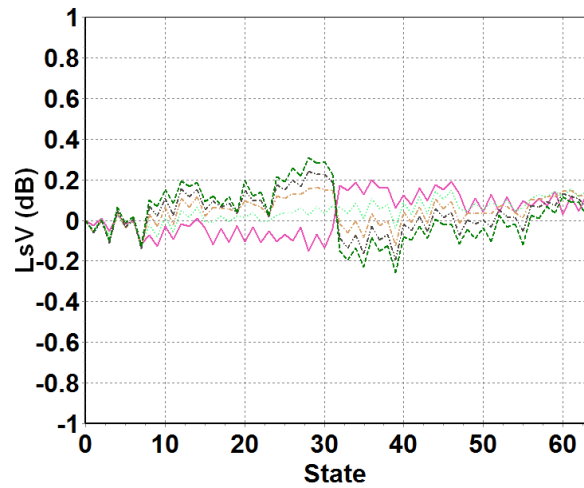

Mechanical dimensions and pads allocation

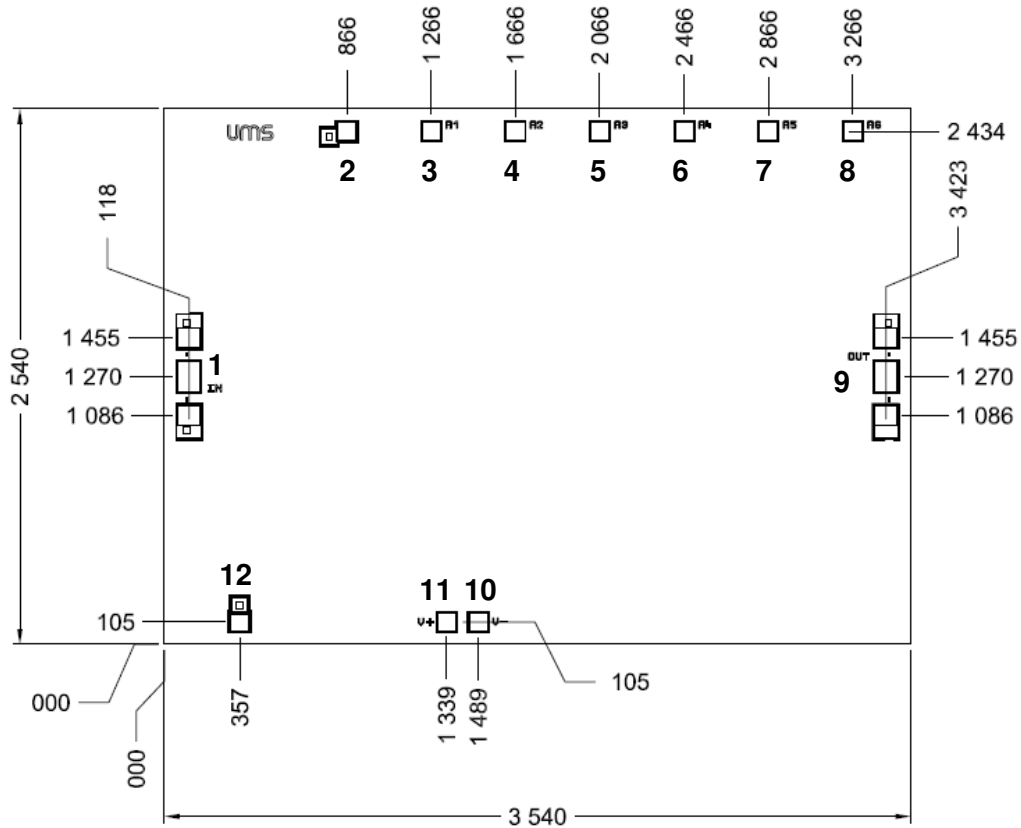

Unit: μm; tolerance: +/- 35μm

Chip thickness = 100μm +/- 10μm

RF pads (1, 9) = 122 x 160μm²

DC and control pads (2, 3, 4, 5, 6, 7, 8, 10, 11, 12) = 100 x 100μm²

Pin number	Pad name	Description
1	IN	Input RF:
3	A1	Shifter bit 1
4	A2	Shifter bit 2
5	A3	Shifter bit 3
6	A4	Shifter bit 4
7	A5	Shifter r bit 5
8	A6	Shifter tor bit 6
9	OUT	Output RF
10	V-	-5V supply voltage: interface
11	V+	+5V supply voltage: interface
2, 12	GND	NC

RF_in and RF_out are AC coupled (serie capacitances inside the circuit).

Bonding recommendations

Port	Connection
IN (1) OUT (9)	Inductance (L _{bonding}) = 0.3nH one wire: diameter 25µm, length 0.4mm
DC and Interface pads	Inductance (L _{bonding}) = 0.8nH one wire: diameter 25µm, length 1.0mm

Recommended assembly diagram

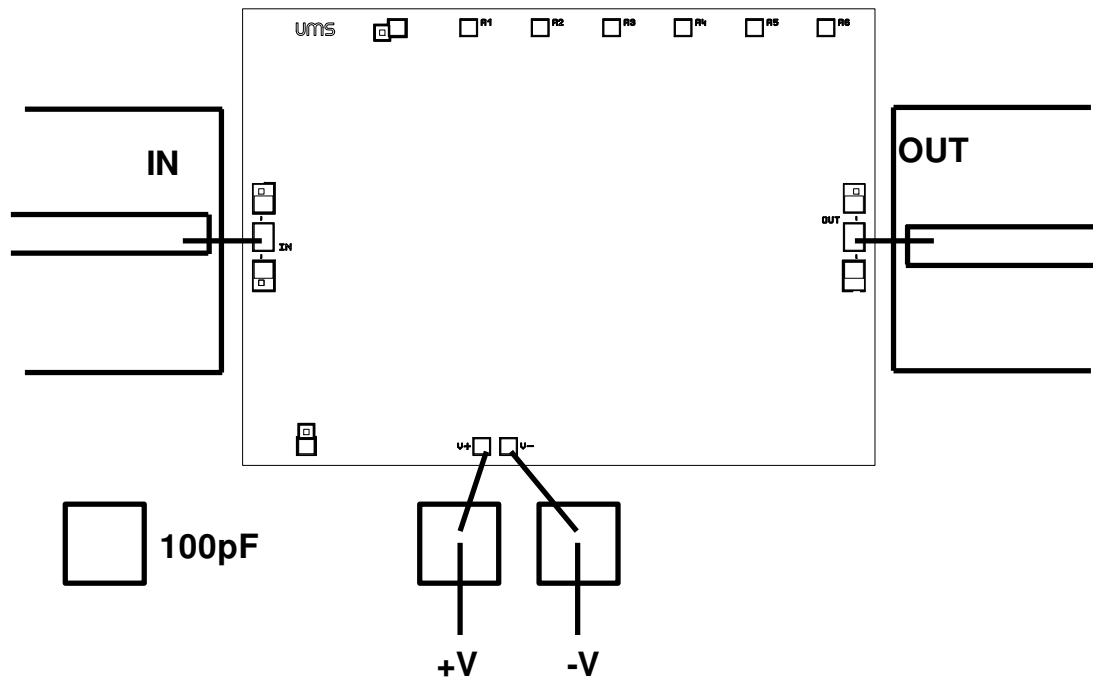

Phase Shifter Control Interface

The 6-bit phase shifter is controlled by 6 control pads (A1 to A6). Reference state is "0". State is "0" when 0V is applied, state is "1" when +3.3V is applied.

State	A1	A2	A3	A4	A5	A6	Phase (deg)
0	0	0	0	0	0	0	0
1	1	0	0	0	0	0	5,625
2	0	1	0	0	0	0	11,25
3	1	1	0	0	0	0	16,875
4	0	0	1	0	0	0	22,5
5	1	0	1	0	0	0	28,125
6	0	1	1	0	0	0	33,75
7	1	1	1	0	0	0	39,375
8	0	0	0	1	0	0	45
9	1	0	0	1	0	0	50,625
10	0	1	0	1	0	0	56,25
11	1	1	0	1	0	0	61,875
12	0	0	1	1	0	0	67,5
13	1	0	1	1	0	0	73,125
14	0	1	1	1	0	0	78,75
15	1	1	1	1	0	0	84,375
16	0	0	0	0	1	0	90
17	1	0	0	0	1	0	95,625
18	0	1	0	0	1	0	101,25
19	1	1	0	0	1	0	106,875
20	0	0	1	0	1	0	112,5
21	1	0	1	0	1	0	118,125
22	0	1	1	0	1	0	123,75
23	1	1	1	0	1	0	129,375
24	0	0	0	1	1	0	135
25	1	0	0	1	1	0	140,625
26	0	1	0	1	1	0	146,25
27	1	1	0	1	1	0	151,875
28	0	0	1	1	1	0	157,5
29	1	0	1	1	1	0	163,125
30	0	1	1	1	1	0	168,75
31	1	1	1	1	1	0	174,375
32	0	0	0	0	0	1	180
33	1	0	0	0	0	1	185,625
34	0	1	0	0	0	1	191,25
35	1	1	0	0	0	1	196,875
36	0	0	1	0	0	1	202,5
37	1	0	1	0	0	1	208,125
38	0	1	1	0	0	1	213,75
39	1	1	1	0	0	1	219,375
40	0	0	0	1	0	1	225
41	1	0	0	1	0	1	230,625
42	0	1	0	1	0	1	236,25
43	1	1	0	1	0	1	241,875
44	0	0	1	1	0	1	247,5
45	1	0	1	1	0	1	253,125
46	0	1	1	1	0	1	258,75
47	1	1	1	1	0	1	264,375
48	0	0	0	0	1	1	270
49	1	0	0	0	1	1	275,625
50	0	1	0	0	1	1	281,25
51	1	1	0	0	1	1	286,875
52	0	0	1	0	1	1	292,5
53	1	0	1	0	1	1	298,125
54	0	1	1	0	1	1	303,75
55	1	1	1	0	1	1	309,375
56	0	0	0	1	1	1	315
57	1	0	0	1	1	1	320,625
58	0	1	0	1	1	1	326,25
59	1	1	0	1	1	1	331,875
60	0	0	1	1	1	1	337,5
61	1	0	1	1	1	1	343,125
62	0	1	1	1	1	1	348,75
63	1	1	1	1	1	1	354,375

Recommended ESD management

Refer to the application note AN0020 available at <http://www.ums-gaas.com> for ESD sensitivity and handling recommendations for the UMS products.

Recommended environmental management

UMS products are compliant with the regulation in particular with the directives RoHS N°2011/65 and REACH N°1907/2006. More environmental data are available in the application note AN0019 also available at <http://www.ums-gaas.com>.

Ordering Information

Chip form:

CHP4014-98F/00

Information furnished is believed to be accurate and reliable. However **United Monolithic Semiconductors S.A.S.** assumes no responsibility for the consequences of use of such information nor for any infringement of patents or other rights of third parties which may result from its use. No license is granted by implication or otherwise under any patent or patent rights of **United Monolithic Semiconductors S.A.S.** Specifications mentioned in this publication are subject to change without notice. This publication supersedes and replaces all information previously supplied. **United Monolithic Semiconductors S.A.S.** products are not authorised for use as critical components in life support devices or systems without express written approval from **United Monolithic Semiconductors S.A.S.**