

13.5-40.5GHz Frequency Multiplier

GaAs Monolithic Microwave IC

Description

The CHX1191-98F is a monolithic time three multiplier which integrates input and output buffer.

The output frequency from 33.7 to 43.5GHz, combined with an output power of 6dBm make of this circuit a very versatile multiplier for telecommunication, specifically for E-band LO chain system.

Moreover it integrates ESD protection. The overall power supply is of +5V/ 80mA.

It is developed on a robust 0.15 μ m gate length pHEMT process, and will be available as a bare die.

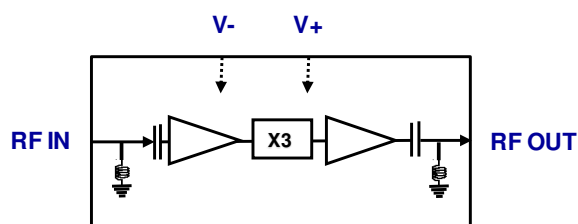

Main Features

- Broadband performances: 11.25-14.5GHz
- 6dBm Pout for -1dBm input power
- DC bias: V+=5 Volts, V- = -5V@Id=80mA
- Chip size 1.77x0.94x0.1mm

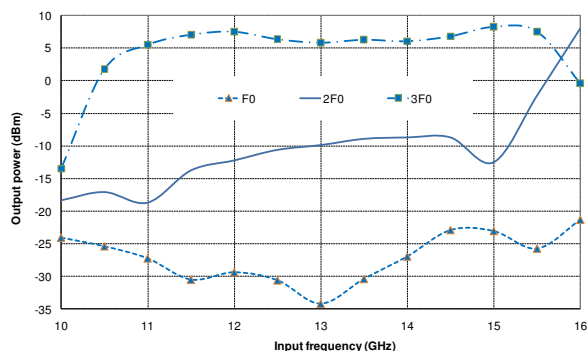

Main Electrical Characteristics

Tamb.= +25°C

Symbol	Parameter	Min	Typ	Max	Unit
Fin	Input frequency range	11.25		14.5	GHz
Fout	Output frequency range	33.75		43.5	GHz
Pin	Input power		-1		dBm
Pout_H3	3rd harmonic output power		6		dBm

Electrical Characteristics

Tamb.= +25°C, V+ = +5.0V

Symbol	Parameter	Min	Typ	Max	Unit
Fin	Input frequency range	11.25		14.5	GHz
Fout	Output frequency range	33.75		43.5	GHz
Pin	Input power		-1		dBm
Pout_H3	3rd harmonic output power		6		dBm
Rej_H1	Fundamental rejection		35		dBc
Rej_H2	2nd harmonic rejection		15		dBc
RL_in	Input return loss		-12		dB
RL_out	Output return loss		-12		dB
V+	DC positive voltage		+5		V
V-	DC negative voltage		-5		V
Id	DC current		80		mA

These values are representative of test fixture measurements with RF bonding around 0.15nH

Absolute Maximum Ratings ⁽¹⁾

Tamb.= +25°C

Symbol	Parameter	Values	Unit
V+	Positive bias voltage	5.5	V
V-	Negative bias current	-6	V
Id	DC current	120	mA
Pin	Maximum input power	+4	dBm
Tj	Junction temperature	175	°C
Ta	Operating temperature range	-40 to +85	°C
Tstg	Storage temperature range	-55 to +150	°C

⁽¹⁾ Operation of this device above anyone of these parameters may cause permanent damage.

Typical Test Fixture Measurements

Tamb.= +25°C, V+ = +5.0V, Id = 80mA

Harmonic output power versus frequency
Pin= -1dBm

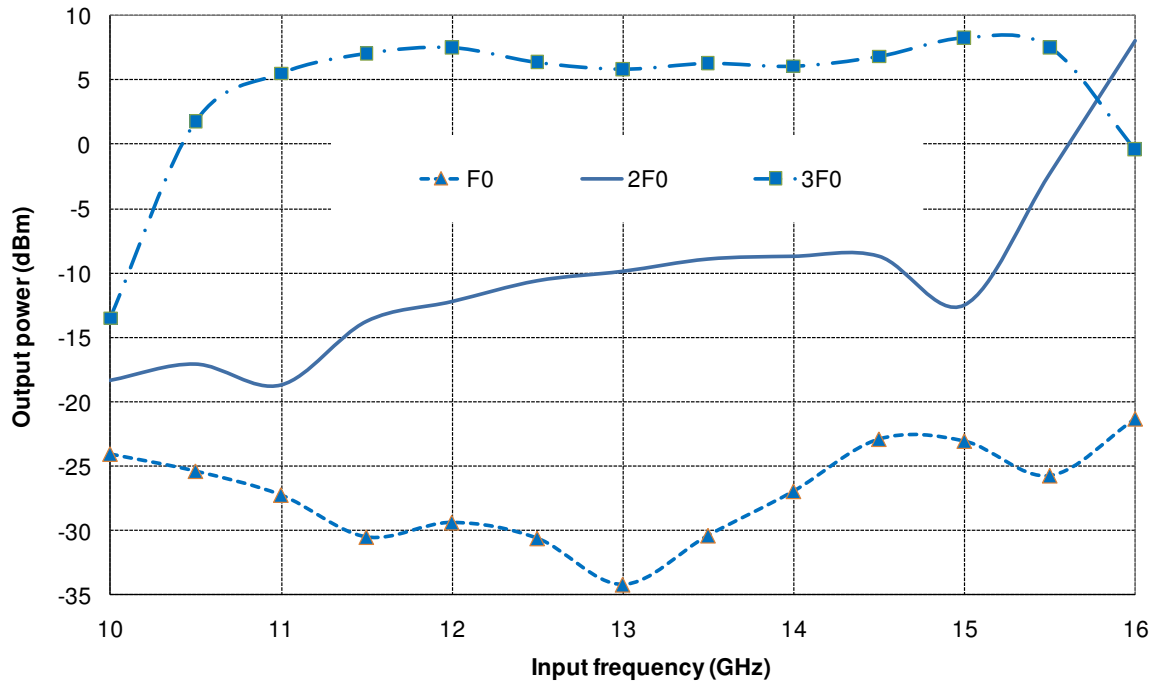

Harmonic output power versus temperature
Pin= -1dBm

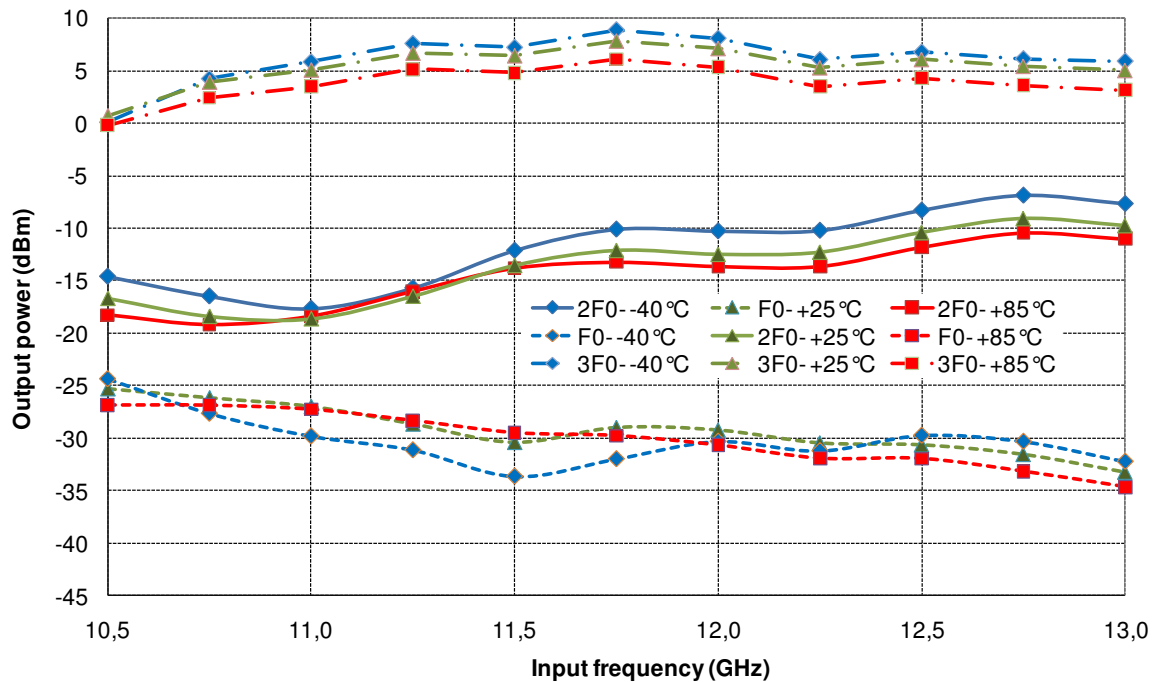

Typical Test Fixture Measurements

Tamb.= +25°C, V+ = +5.0V, Id = 80mA

Harmonic output power versus input power
F0=11.5GHz

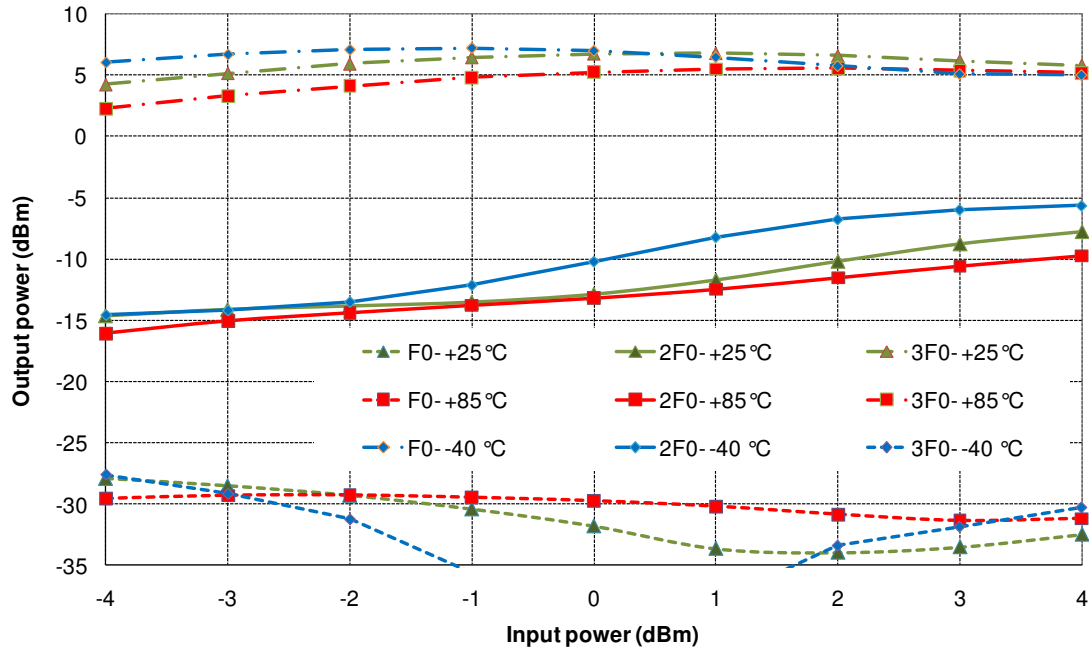

Input & Output return loss

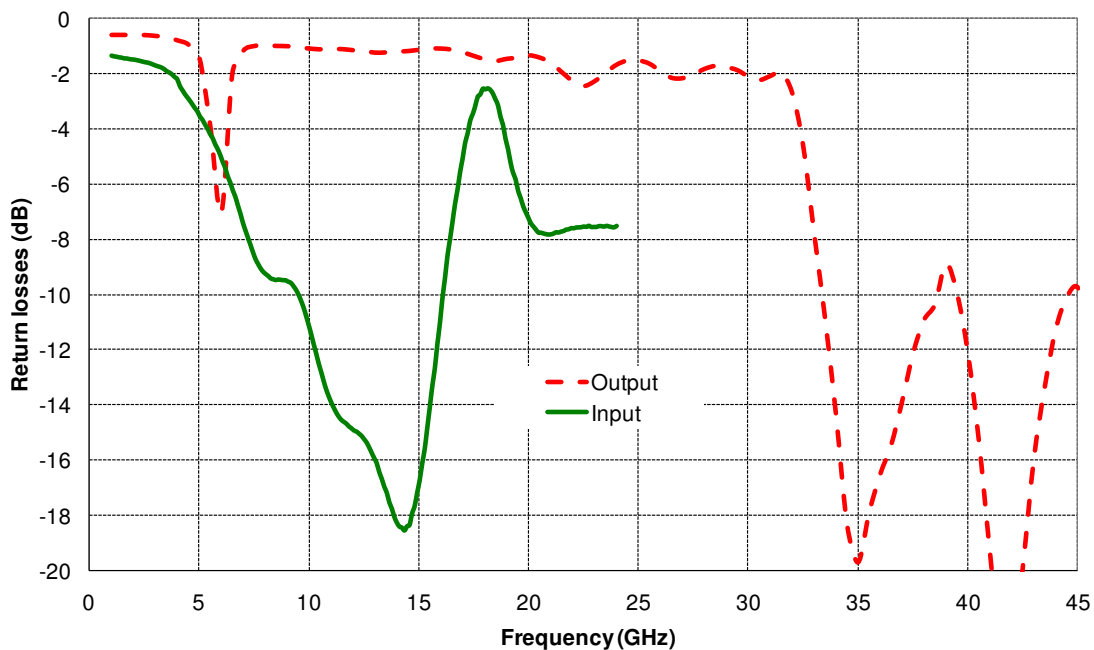

Mechanical data

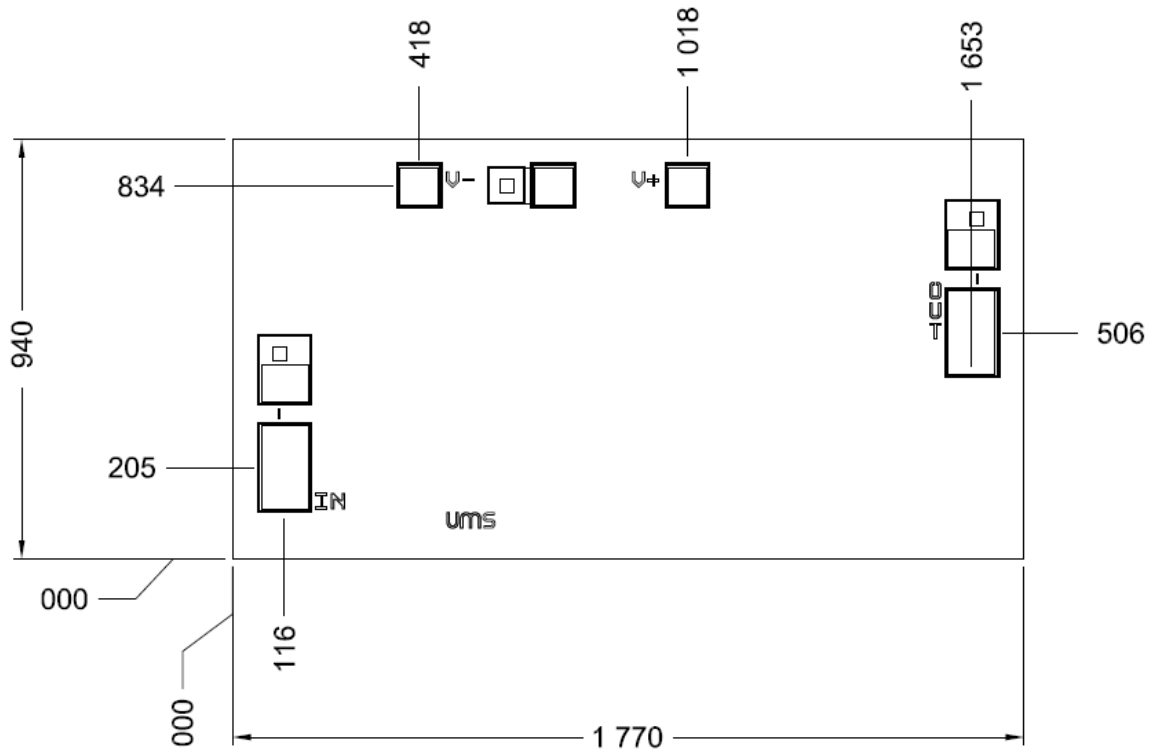

Chip thickness: 100μm.

Chip size: 1770x940 ±35μm

All dimensions are in micrometers

Recommended assembly plan

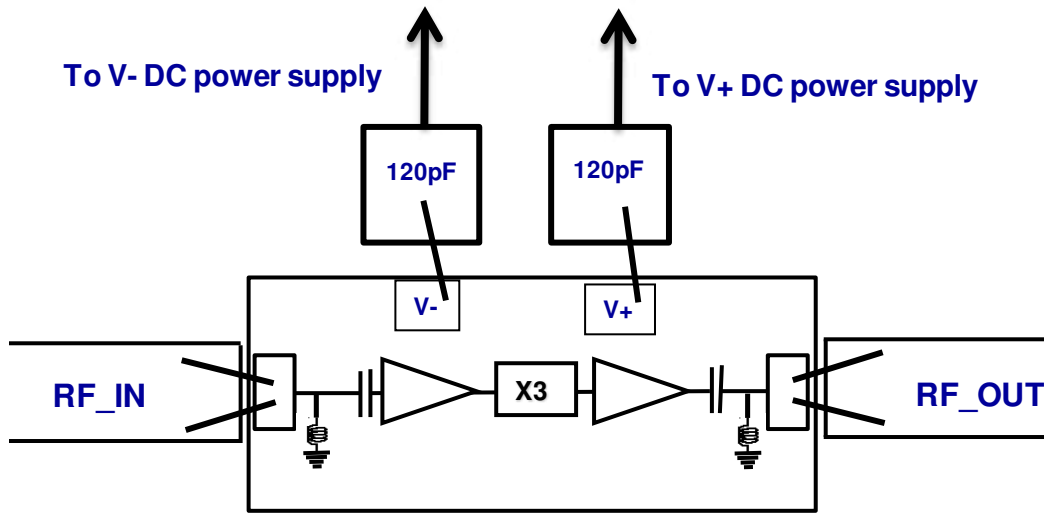

25µm wedge bonding is preferred

Note: Supply feed should be bypassed. 25µm diameter gold wire is preferred. Two wires are recommended to minimize the equivalent self inductance. (0.15nH should be targeted).

Recommended circuit bonding table

Label	Type	Decoupling	Comment
RF_IN		Required if external voltage	Inductance (Lbonding) = 0.3nH Two wires: length 0.6mm
RF_OUT		Required if external voltage	Inductance (Lbonding) = 0.3nH Two wires: length 0.6mm
V+	Vd	120pF	Drain Supply
V+	Vg	120pF	Gate Supply

Evaluation mother board

- Compatible with the proposed footprint.
- Based on typically Ro4003 / 8mils or equivalent.
- Decoupling capacitors of 120pF \pm 10% are recommended for all DC accesses.

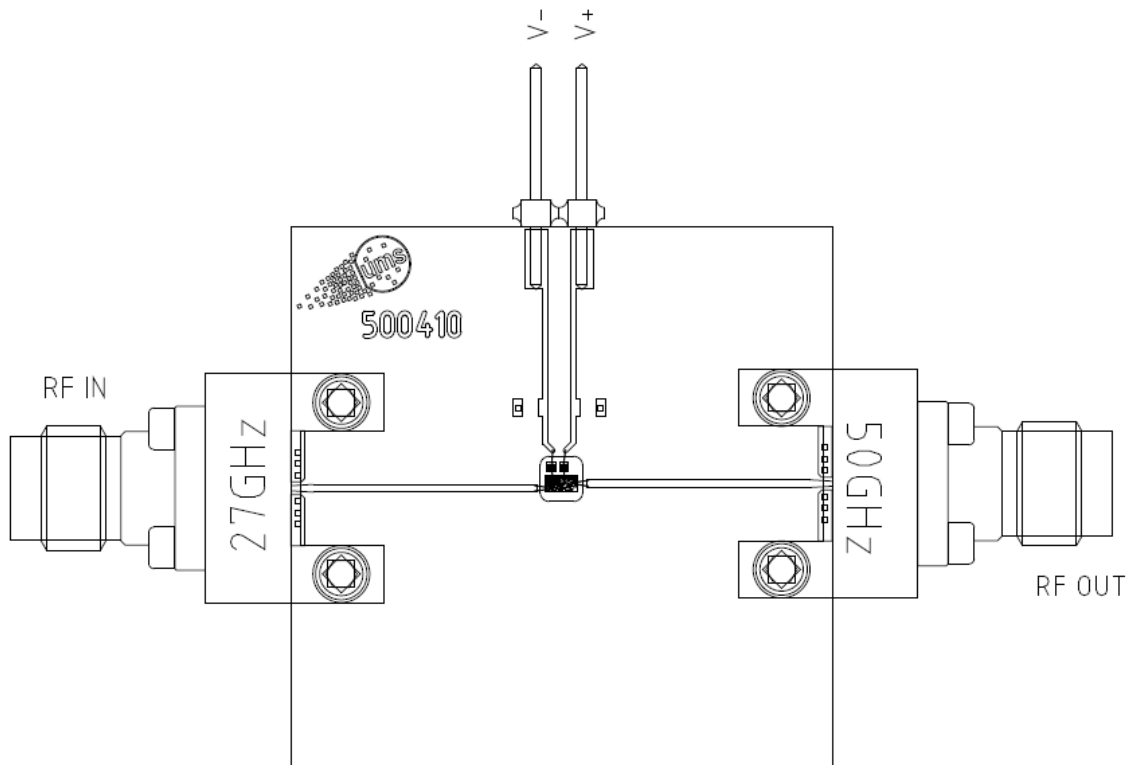

Notes

Due to ESD protection circuits on RF input and output, an external capacitance might be requested to isolate the product from external voltage that could be present on the RF accesses.

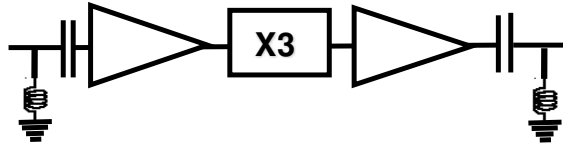

Due to BCB coating on the chip, epoxy die attached is required.

DC Schematic

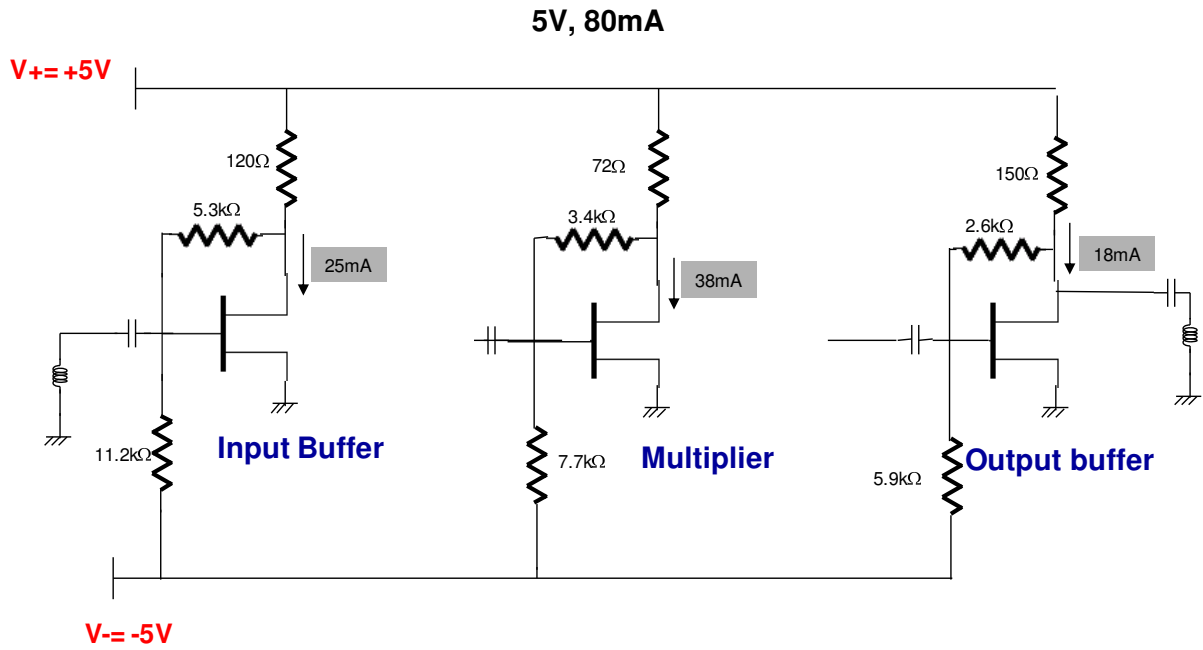

Recommended ESD management

Refer to the application note AN0020 available at <http://www.ums-gaas.com> for ESD sensitivity and handling recommendations for the UMS products.

Recommended environmental management

UMS products are compliant with the regulation in particular with the directives RoHS N°2011/65 and REACH N°1907/2006. More environmental data are available in the application note AN0019 also available at <http://www.ums-gaas.com>.

Ordering Information

Chip form:

CHX1191-98F/00

Information furnished is believed to be accurate and reliable. However **United Monolithic Semiconductors S.A.S.** assumes no responsibility for the consequences of use of such information nor for any infringement of patents or other rights of third parties which may result from its use. No license is granted by implication or otherwise under any patent or patent rights of **United Monolithic Semiconductors S.A.S.** Specifications mentioned in this publication are subject to change without notice. This publication supersedes and replaces all information previously supplied. **United Monolithic Semiconductors S.A.S.** products are not authorised for use as critical components in life support devices or systems without express written approval from **United Monolithic Semiconductors S.A.S.**