

36-40GHz Very Low Noise Amplifier

GaAs Monolithic Microwave IC

Description

The CHA2391 is a two-stage wide band monolithic low noise amplifier.

The circuit is manufactured with a standard pHEMT process: 0.25 μ m gate length, via holes through the substrate, air bridges and electron beam gate lithography.

It is supplied in chip form.

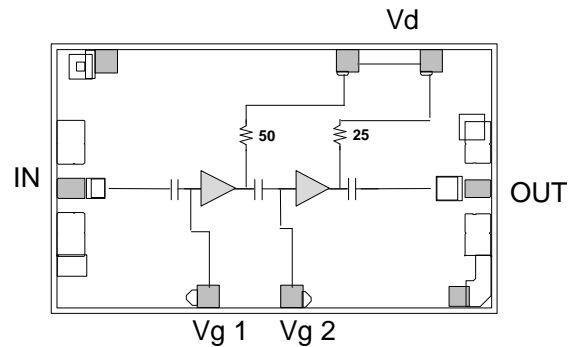

Main Features

- Broad band performance 36-40GHz
- 2.5dB noise figure, 36-40GHz
- 15dB gain, ± 0.5 dB gain flatness
- Low DC power consumption, 50mA
- 20dBm 3rd order intercept point
- Chip size: 1.67 x 1.03 x 0.1mm

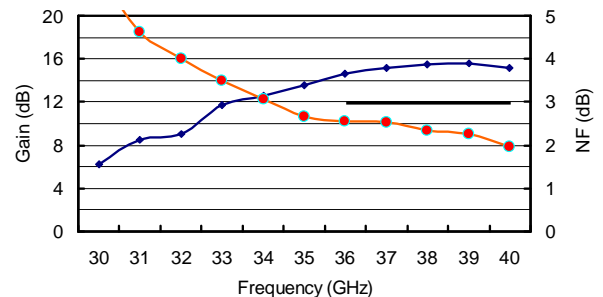

On wafer typical measurements

Main Characteristics

Tamb = +25°C

| Symbol | Parameter | Min | Typ | Max | Unit |
|--------|--------------------------------------|-----|-----|-----|------|
| Fop | Operating frequency range | 36 | | 40 | GHz |
| NF | Noise figure, 36-40GHz | | 2.5 | 3 | dB |
| G | Gain | 12 | 15 | | dB |
| P1dB | Output power at 1dB gain compression | | 9 | | dBm |

ESD Protections : Electrostatic discharge sensitive device observe handling precautions !

Electrical Characteristics

Tamb = +25°C, Bias Conditions: Vd = +4V

| Symbol | Parameter | Min | Typ | Max | Unit |
|---------|--------------------------------------|-----|-------|-------|------|
| Fop | Operating frequency range | 36 | | 40 | Ghz |
| G | Gain (1) | 12 | 15 | | dB |
| ΔG | Gain flatness (1) | | ± 0.5 | ± 1.0 | dB |
| NF | Noise figure (1) | | 2.5 | 3 | dB |
| VSWRin | Input VSWR (1) | | | 3.0:1 | |
| VSWRout | Ouput VSWR (1) | | | 3.0:1 | |
| IP3 | 3rd order intercept point | | 20 | | dBm |
| P1dB | Output power at 1dB gain compression | | 12 | | dBm |
| Vd | DC Voltage | | 4 | 4.5 | V |
| | Vd | -2 | -0.25 | +0.4 | |
| | Vg | | | | |
| Id | Drain bias current (2) | | 45 | | mA |

(1) These values are representative of on-wafer measurements that are made without bonding wires at the RF ports. When the chip is attached with typical 0.15nH input and output bonding wires, the indicated parameters should be improved.

(2) 45 mA is the typical bias current used for on wafer measurements, with Vg1= Vg2. For optimum noise figure, the bias current could be reduced down to 30 mA, adjusting the Vg1,2 voltage.

Absolute Maximum Ratings (1)

Tamb = +25°C

| Symbol | Parameter | Values | Unit |
|--------|--|--------------|------|
| Vd | Drain bias voltage | 5.0 | V |
| Vg | Gate bias voltage | -2.0 to +0.4 | V |
| Vdg | Maximum drain to gate voltage (Vd-Vg) | +5.0 | V |
| Pin | Maximum peak input power overdrive (2) | +15 | dBm |
| Pin | Maximum continuous input power | +1 | dBm |
| Top | Operating temperature range | -40 to +85 | °C |
| Tsg | Storage temperature range | -55 to +125 | °C |

(1) Operation of this device above any one of these parameters may cause permanent damage.

(2) Duration < 1s.

Typical Results

Chip Typical Response (On wafer Sij)

Tamb = +25°C

Bias conditions: Vd = +4V, Id=45mA

| Freq GHz | MS11 dB | PS11 ° | MS12 dB | PS12 ° | MS21 dB | PS21 ° | MS22 dB | PS22 ° |
|-------------|---------------|--------------|---------------|---------------|--------------|--------------|---------------|---------------|
| 10 | -6,21 | 154,25 | -62,67 | -132,87 | -22,58 | 67,85 | -2,93 | -143,42 |
| 12 | -6,33 | 141,75 | -57,99 | -156,02 | -16,83 | 50,10 | -3,89 | -164,87 |
| 14 | -6,29 | 127,36 | -55,17 | 173,41 | -12,52 | 23,11 | -4,95 | 178,26 |
| 16 | -6,08 | 114,92 | -55,88 | 168,49 | -9,73 | -5,37 | -5,86 | 161,51 |
| 18 | -5,84 | 101,82 | -53,92 | 135,46 | -7,54 | -31,47 | -7,18 | 144,01 |
| 20 | -5,54 | 86,62 | -51,45 | 138,48 | -6,13 | -55,85 | -8,65 | 131,69 |
| 21 | -5,43 | 78,44 | -50,53 | 139,32 | -5,41 | -67,16 | -9,65 | 127,30 |
| 22 | -5,30 | 68,96 | -49,42 | 132,07 | -4,82 | -77,06 | -10,46 | 125,73 |
| 23 | -5,29 | 58,88 | -49,04 | 122,68 | -4,06 | -85,86 | -11,18 | 124,83 |
| 24 | -5,35 | 47,97 | -49,34 | 123,59 | -3,25 | -94,05 | -11,33 | 125,87 |
| 25 | -5,54 | 35,38 | -47,96 | 126,63 | -2,19 | -101,60 | -11,19 | 124,77 |
| 26 | -5,87 | 21,00 | -46,55 | 123,65 | -0,88 | -110,55 | -11,01 | 125,49 |
| 27 | -6,47 | 3,87 | -44,77 | 125,28 | 0,38 | -119,43 | -10,17 | 122,17 |
| 28 | -7,39 | -16,23 | -43,13 | 124,81 | 1,88 | -128,85 | -9,43 | 117,25 |
| 29 | -8,77 | -41,92 | -40,03 | 123,61 | 3,63 | -138,80 | -9,11 | 109,58 |
| 30 | -10,69 | -77,04 | -37,67 | 115,28 | 5,50 | -151,53 | -8,70 | 103,41 |
| 31 | -12,44 | -127,88 | -35,70 | 105,15 | 7,35 | -166,04 | -8,15 | 94,50 |
| 32 | -12,19 | 170,79 | -33,04 | 93,43 | 9,18 | 176,87 | -7,69 | 83,88 |
| 33 | -10,65 | 120,05 | -31,11 | 75,77 | 10,75 | 158,36 | -7,59 | 70,55 |
| 34 | -9,85 | 82,96 | -29,60 | 58,30 | 12,14 | 138,69 | -7,80 | 56,02 |
| 35 | -9,98 | 54,87 | -28,64 | 42,10 | 13,37 | 117,54 | -8,57 | 40,66 |
| 36 | -10,94 | 33,47 | -27,69 | 26,41 | 14,27 | 95,66 | -9,80 | 25,19 |
| 37 | -12,52 | 20,51 | -26,89 | 9,83 | 14,95 | 73,24 | -11,70 | 9,54 |
| 38 | -13,72 | 17,24 | -26,15 | -5,87 | 15,28 | 51,13 | -14,31 | -4,52 |
| 39 | -13,22 | 18,64 | -25,53 | -22,03 | 15,46 | 29,79 | -17,89 | -18,79 |
| 40 | -11,65 | 9,29 | -25,06 | -38,88 | 15,53 | 8,33 | -23,80 | -30,52 |
| 41 | -10,30 | -3,86 | -24,91 | -56,23 | 15,40 | -12,86 | -51,61 | -16,72 |
| 42 | -8,90 | -20,55 | -24,74 | -72,65 | 15,17 | -32,98 | -26,28 | 118,15 |
| 43 | -7,51 | -38,62 | -24,62 | -88,50 | 14,89 | -52,97 | -20,52 | 111,87 |
| 44 | -6,22 | -59,90 | -24,63 | -105,66 | 14,54 | -73,10 | -17,09 | 101,92 |
| 45 | -5,17 | -81,47 | -24,78 | -122,84 | 14,05 | -93,80 | -14,60 | 89,21 |
| 46 | -4,24 | -102,42 | -25,30 | -139,10 | 13,39 | -113,54 | -12,92 | 73,66 |
| 47 | -3,18 | -122,95 | -25,65 | -155,88 | 12,59 | -133,30 | -11,93 | 59,95 |
| 48 | -2,51 | -143,29 | -26,29 | -173,89 | 11,55 | -152,49 | -11,14 | 47,16 |
| 49 | -2,04 | -161,80 | -27,21 | 170,58 | 10,40 | -170,65 | -10,65 | 35,08 |
| 50 | -1,62 | -178,03 | -27,82 | 157,24 | 9,39 | 172,00 | -9,69 | 20,78 |

Typical Results

Chip Typical Response (On wafer Si_j)

T_{amb} = +25°C
 V_d = +4V I_d=45mA

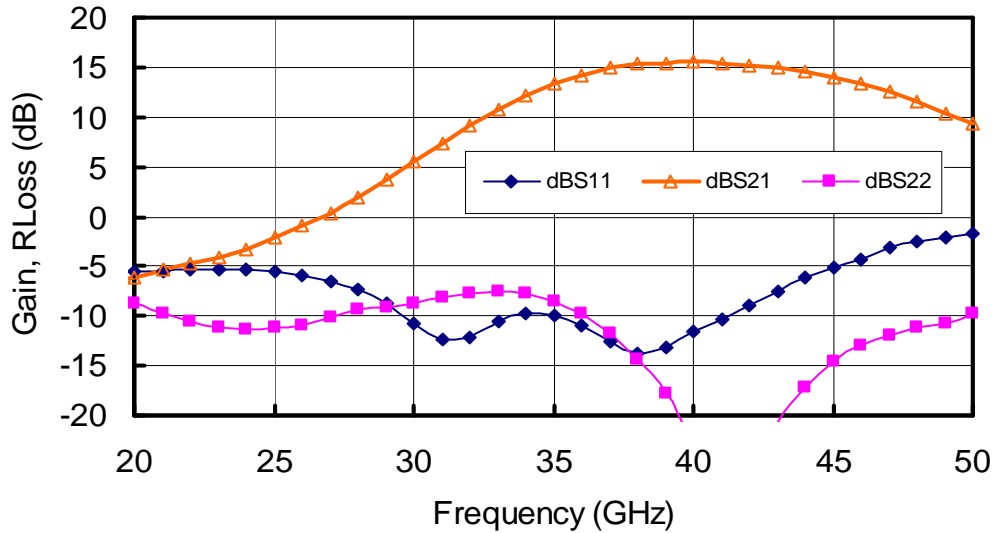

Typical Gain and Matching measurements on wafer

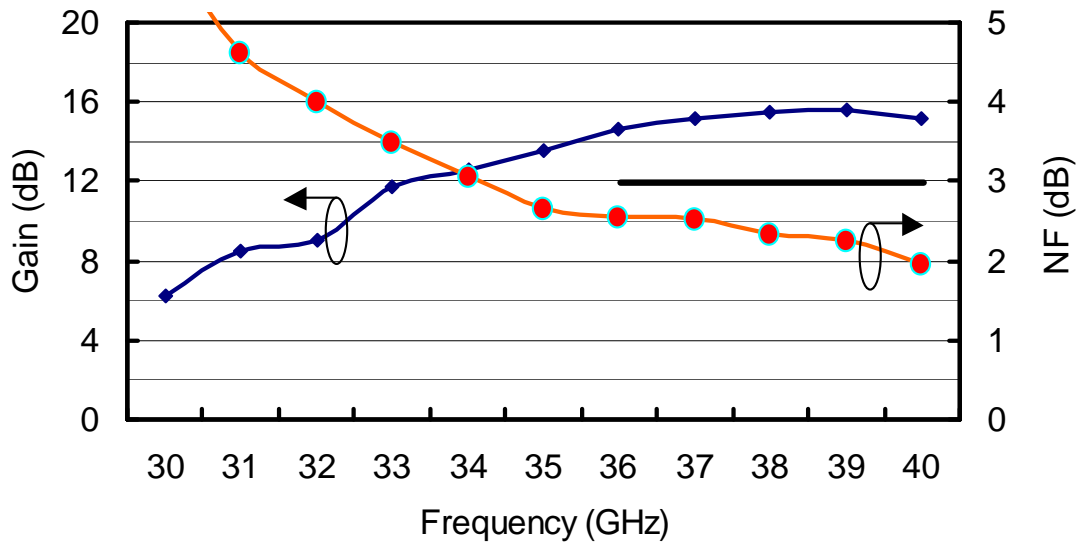

Typical Gain and Noise Figure measurements on wafer

Typical Results

Tamb = +25°C

Vd = 4V ; Id = 45mA

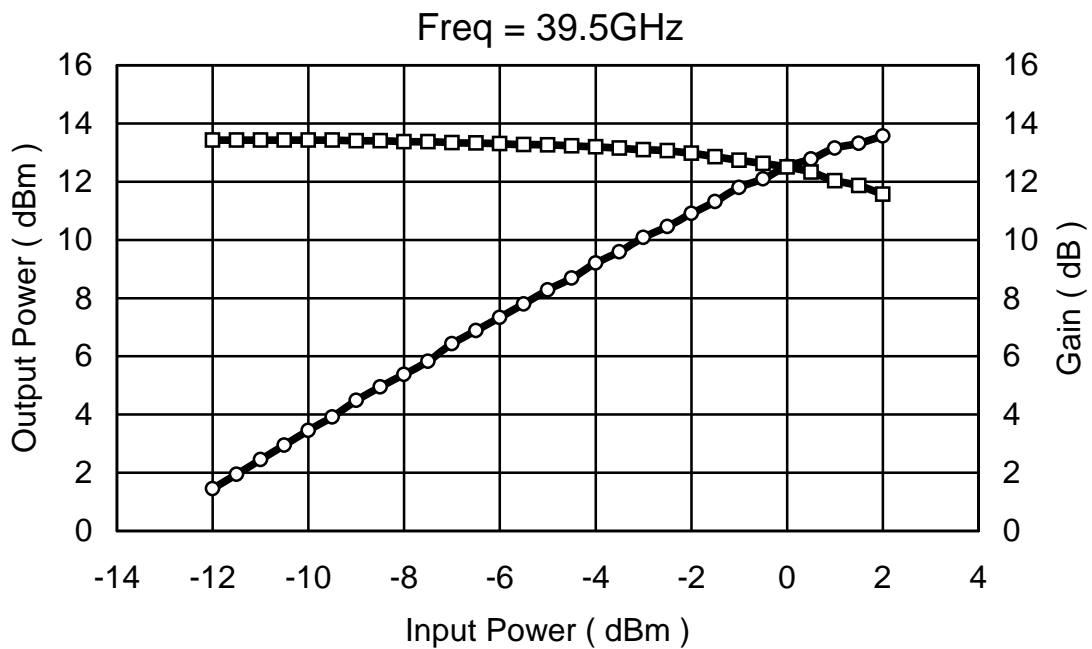
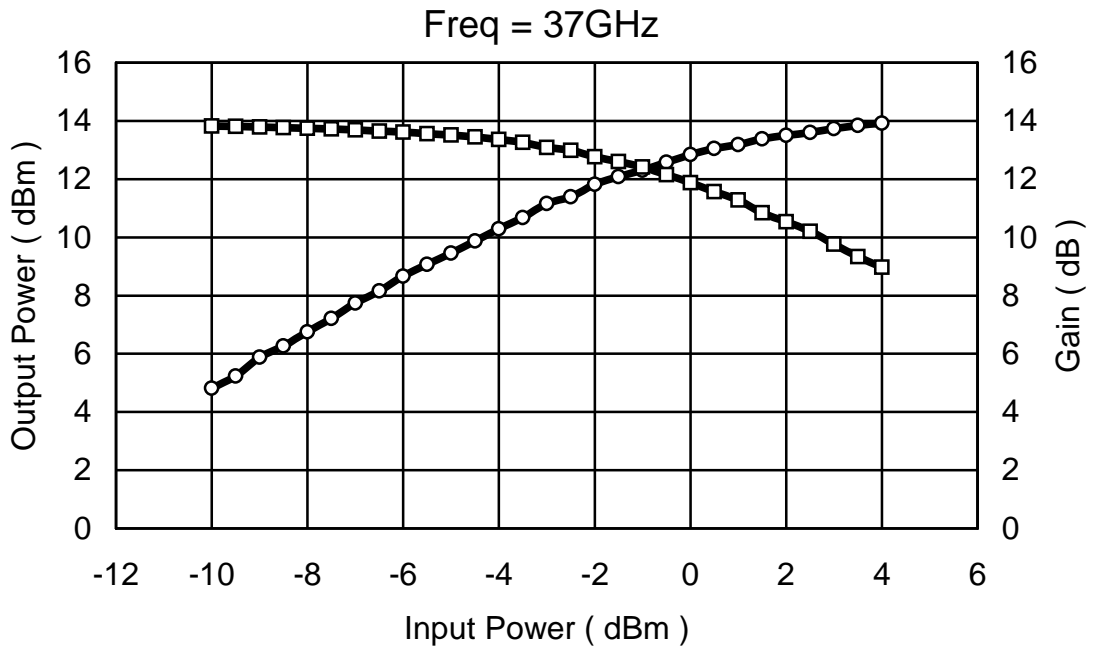

**Typical Output Power and Gain measurements in test jig
(included losses of the jig)**

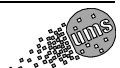

Typical Chip Assembly

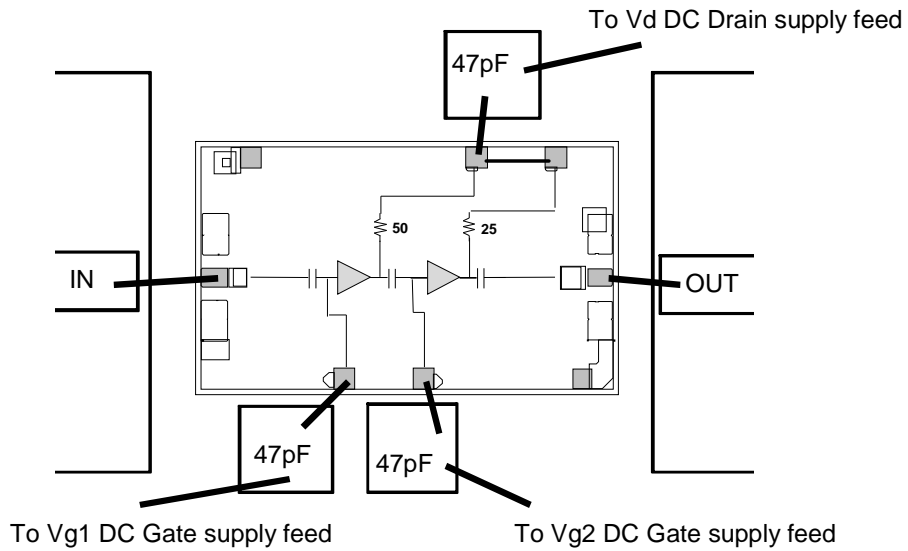

Note: Supply feed should be capacitively bypassed.

Mechanical data

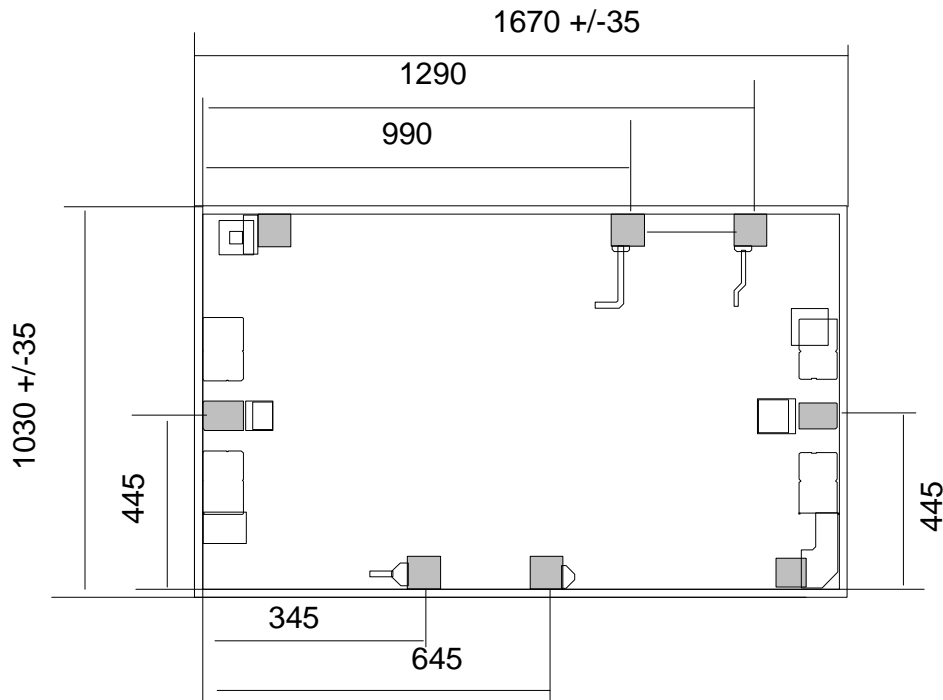

Bonding pad positions.

(Chip thickness: 100µm. All dimensions are in micrometers)

Chip Biasing

This chip is a two stage amplifier, and flexibility is provided by the access to number of pads. The internal DC electrical schematic is given in order to use these pads in a safe way.

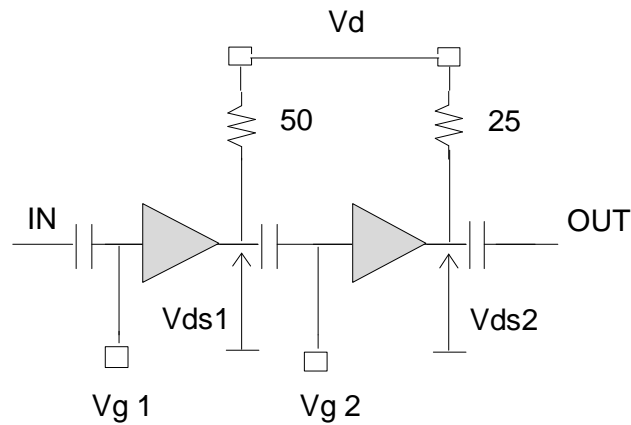

Not exceed $V_{ds} = 3.5\text{V}$ (internal Drain to Source voltage).

We propose two standard biasing:

Low Noise and low consumption: $V_d = 3.5\text{V}$ and $I_d = 30\text{mA}$.

Low Noise and high output power: $V_d = 4.0\text{V}$ and $I_d = 45\text{mA}$. (A separate access to the gate voltages of the first and the output stage is provided. Nominal bias is obtained for a typical current of 30mA for the output stage and 15 mA for the first stage. The first step to bias the amplifier is to tune the $V_{g1} = -1\text{V}$ and V_{g2} to drive 30mA for the full amplifier. Then V_{g1} is reduced to obtain 45 mA of current through the amplifier.

Ordering Information

Chip form : CHA2391-99F/00

Information furnished is believed to be accurate and reliable. However **United Monolithic Semiconductors S.A.S.** assumes no responsibility for the consequences of use of such information nor for any infringement of patents or other rights of third parties which may result from its use. No license is granted by implication or otherwise under any patent or patent rights of **United Monolithic Semiconductors S.A.S.** Specifications mentioned in this publication are subject to change without notice. This publication supersedes and replaces all information previously supplied. **United Monolithic Semiconductors S.A.S.** products are not authorised for use as critical components in life support devices or systems without express written approval from **United Monolithic Semiconductors S.A.S.**