

18-32GHz Low Noise Amplifier

GaAs Monolithic Microwave IC

Description

The CHA2092 is a high gain broadband three-stage monolithic low noise amplifier. It is designed for a wide range of applications, from military to commercial communication systems. The backside of the chip is both RF and DC ground. This helps simplify the assembly process. Self biasing technique is implemented on chip to ease the circuit biasing.

The circuit is manufactured with a pHEMT process, 0.25 μ m gate length, via holes through the substrate, air bridges and electron beam gate lithography. It is available in chip form.

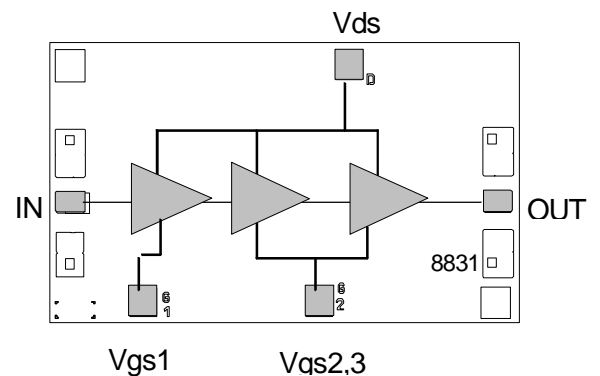

Main Features

- Broadband performances: 18-32GHz
- 2.5dB Noise Figure
- 10dBm output power (-1dB gain comp.)
- 22dB \pm 1.0dB gain
- Low DC power consumption, 60mA @ 3.5V
- Chip size: 1.67 X 0.97 X 0.10mm

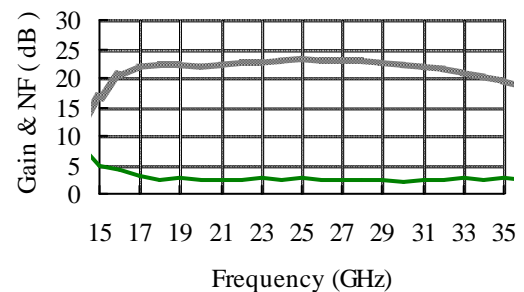

Main Characteristics

Tamb. = 25°C

Symbol	Parameter	Min	Typ	Max	Unit
Fop	Operating frequency range	18		32	GHz
G	Small signal gain	17	22		dB
NF	Noise figure (20-32GHz)		2.5	3.5	dB
P1dB	Output power at 1dB gain compression	8	10		dBm
Id	Bias current		60	100	mA

ESD Protection : Electrostatic discharge sensitive device. Observe handling precautions !

Electrical Characteristics

Tamb = +25°C, Vds = 3.5V; Ids=60mA

Symbol	Parameter	Min	Typ	Max	Min	Typ	Max	Unit
Fop	Operating frequency range (1)	20		28	18		32	GHz
G	Small signal gain (1)	18	22		17	22		dB
ΔG	Small signal gain flatness (1)		±1.5			±2.5		dB
ΔGsb	Gain flatness over 40MHz			0.5			0.5	dBpp
Is	Reverse isolation (1)	25	30		25	30		dB
P1dB	Output power at 1dB gain compression (3)	8	10		8	10		dBm
VSWRin	Input VSWR (1)		2.5:1	3.0:1		2.5:1	3.5:1	
VSWRout	Output VSWR (1)		2.5:1	3.0:1		2.5:1	3.5:1	
NF	Noise figure (2)		2.5	3.5		2.5 2.5 2.5	4 3.5 3.5	dB
Vd	DC Voltage Vd Vgs1, Vgs2&3		3.5 -0.5	4.5		3.5 -0.5	4.5	V V
Id	Bias current (2)		60	100		60	100	mA

(1) These values are representative of on-wafer measurements that are made without bonding wires at the RF ports.

(2) 60 mA is the typical bias current used for on wafer measurements, with Vgs1 and Vgs2&3 connected together. For optimum noise figure, the bias current could be reduced down to 50 mA, adjusting the Vgs1 voltage.

(3) Ids=90mA

Absolute Maximum Ratings

Tamb. = 25°C (1)

Symbol	Parameter	Values	Unit
Vd	Drain bias voltage	5.0	V
Id	Drain bias current	120	mA
Vg	Gate bias voltage	-2.0 to +0.4	V
Pin	Maximum peak input power overdrive (2)	+15	dBm
Ta	Operating temperature range	-40 to +85	°C
Tstg	Storage temperature range	-55 to +155	°C

(1) Operation of this device above any one of these parameters may cause permanent damage.

(2) Duration < 1s.

Typical Results

Tamb=25°C

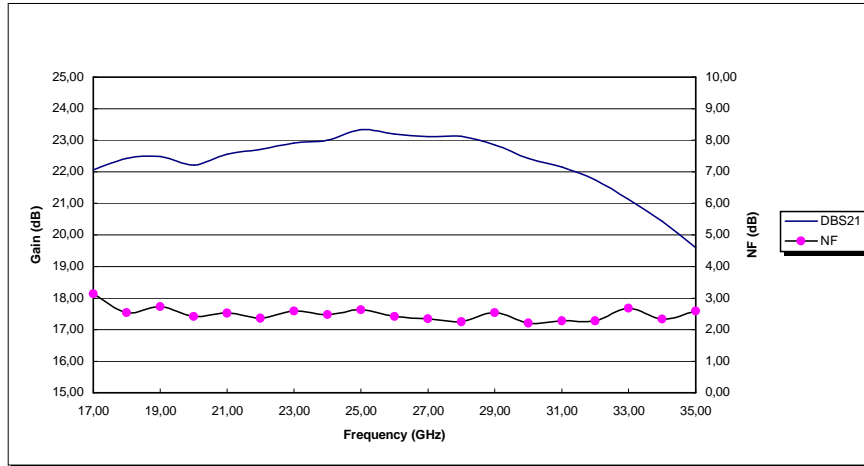

Gain and NF vs Frequency (Vdd=3.5V; Ids=60mA)

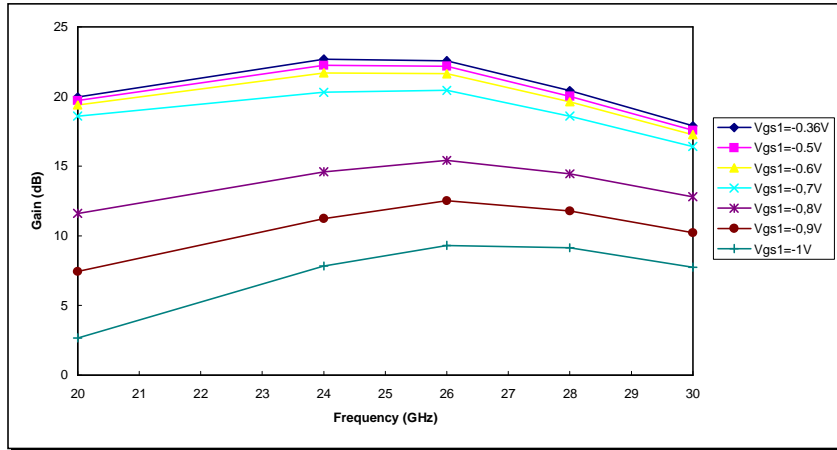

Gain vs Frequency and Vgs1 (Vdd=3.5V; Vgs23=-0.3V)

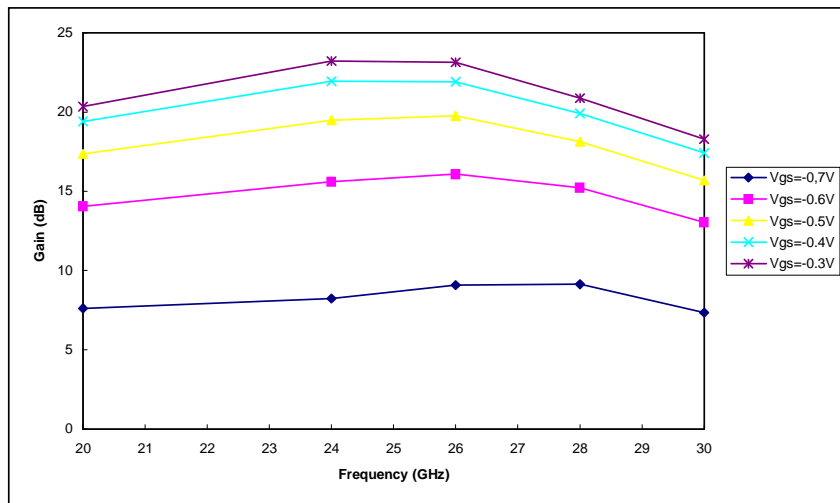

Gain vs Frequency and Vgs123 (Vdd=3.5V)

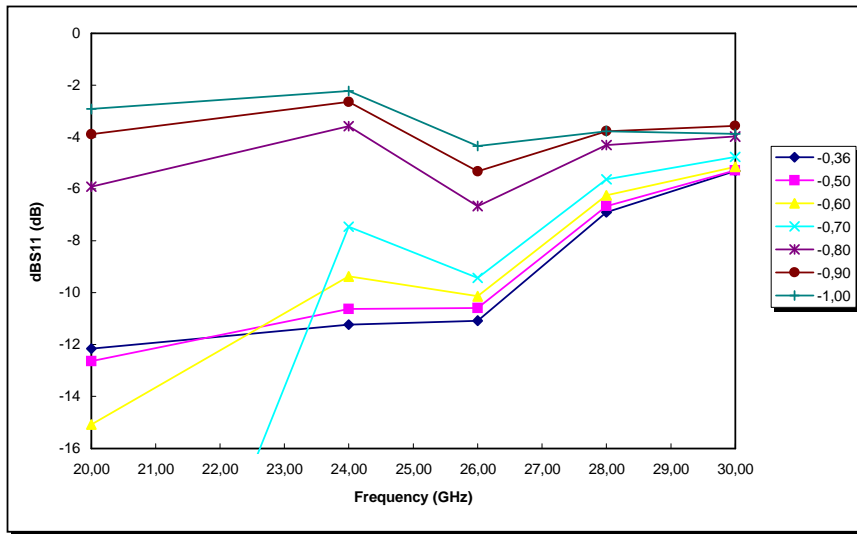

dBS11 vs Frequency and Vgs1 (Vdd=3.5V; Vgs23=-0.3V)

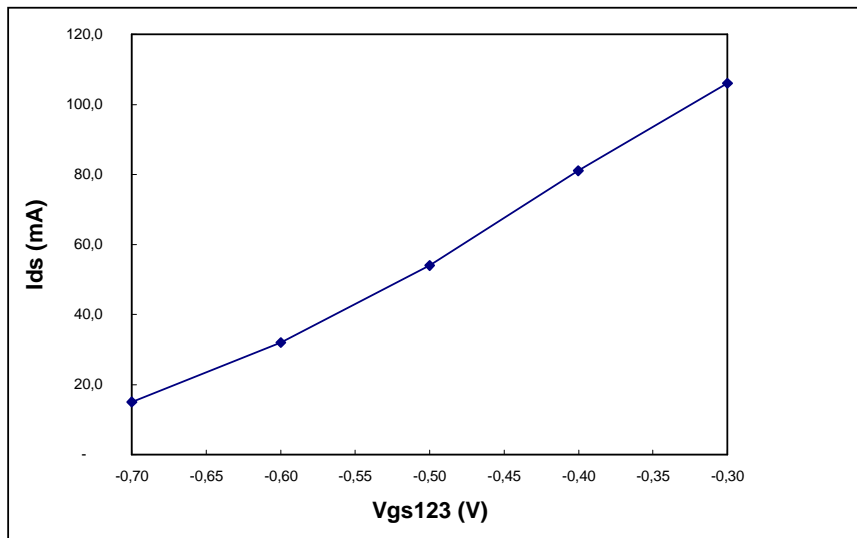

Ids vs Vgs123 (Vdd=3.5V)

Chip Assembly and Mechanical Data

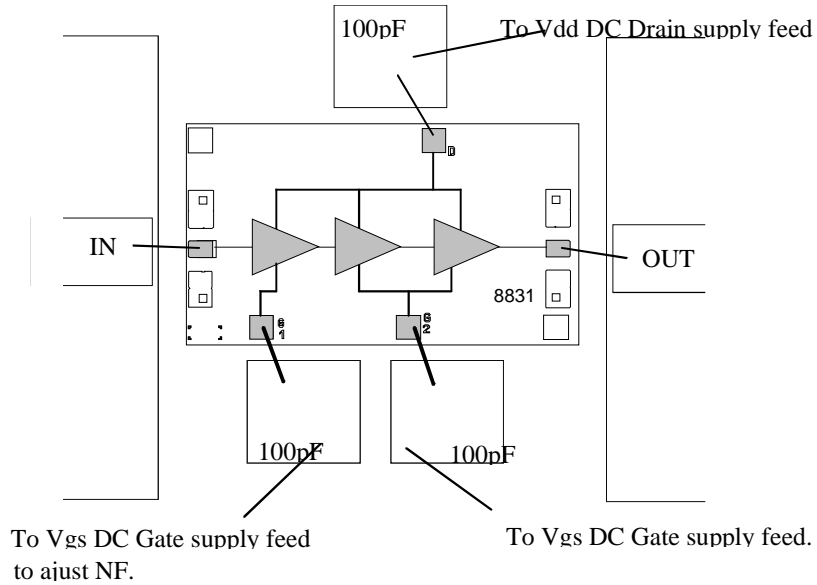

Note : Supply feed should be capacitively bypassed.

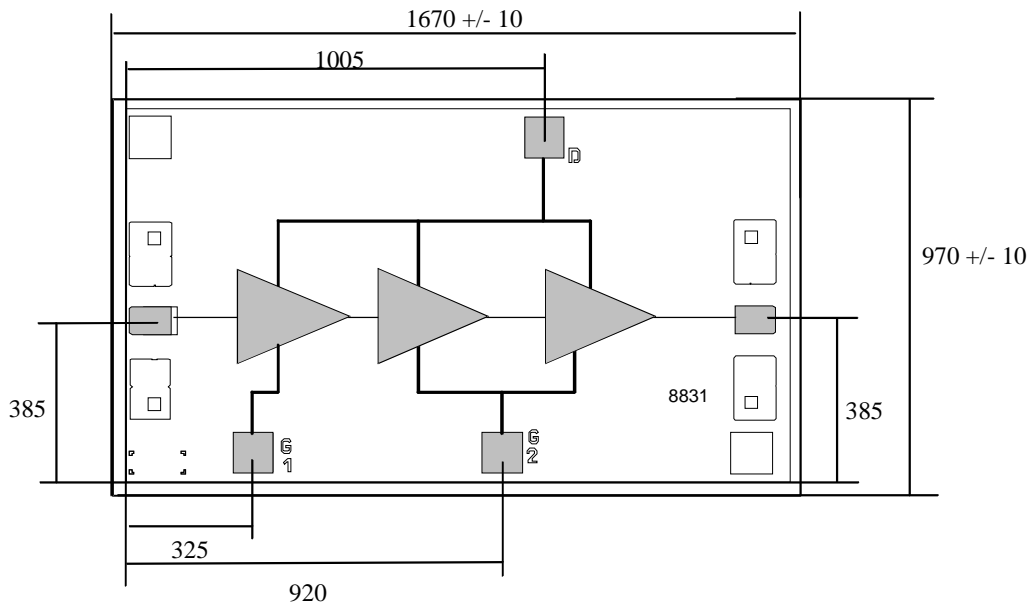

Bonding pad positions.

(Chip thickness: 100µm. All dimensions are in micrometers)

Typical Bias Tuning

The circuit schematic is given below:

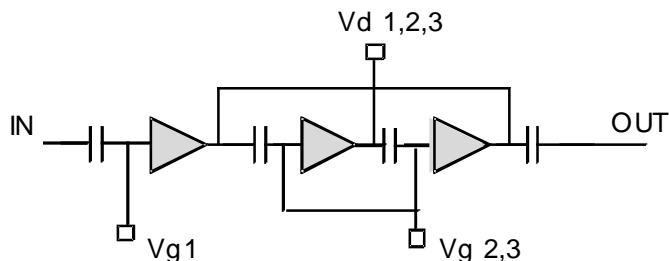

The three drain biases are connected altogether on chip. For typical operation, all the gate biases are connected together at the same power supply, tuned to drive a small signal operating current of 60 mA. A separate access to the gate voltages of the first stage (Vg1) and the second and third stages (Vgs2,3) is provided for the fine tuning of the amplifier regarding the application.

Ordering Information

Chip form : CHA2092b99F/00

Information furnished is believed to be accurate and reliable. However **United Monolithic Semiconductors S.A.S.** assumes no responsibility for the consequences of use of such information nor for any infringement of patents or other rights of third parties which may result from its use. No license is granted by implication or otherwise under any patent or patent rights of **United Monolithic Semiconductors S.A.S.** Specifications mentioned in this publication are subject to change without notice. This publication supersedes and replaces all information previously supplied. **United Monolithic Semiconductors S.A.S.** products are not authorised for use as critical components in life support devices or systems without express written approval from **United Monolithic Semiconductors S.A.S.**