

18-30GHz Low Noise Amplifier

GaAs Monolithic Microwave IC in SMD leadless package

Description

The CHA2069-QDG is a three-stage self-biased wide band monolithic low noise amplifier. Typical applications range from telecommunication (point to point, point to multi-point, VSAT) to ISM and military markets.

The circuit is manufactured with a standard pHEMT process: 0.25µm gate length, via holes through the substrate, air bridges and electron beam gate lithography.

It is supplied in lead-free SMD package.

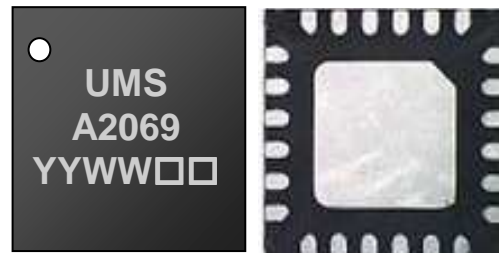

Gain and NF @ high current configuration (BCF grounded)

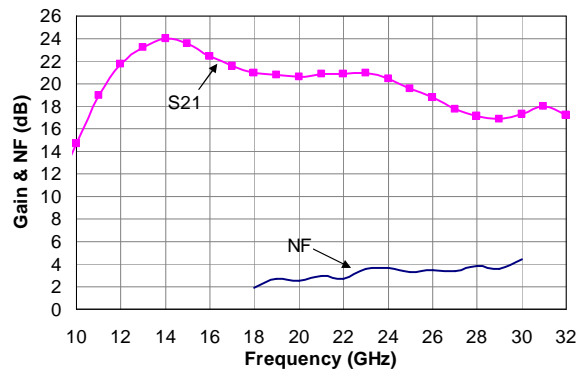

Main Features

- Broadband performance 18-30GHz
- 3dB noise figure
- 20dB gain
- 65mA low DC power consumption
- 20dBm 3rd order intercept point (high current configuration)
- 24L-QFN4x4 SMD package
- MSL Level: 1

Main Characteristics

Tamb = +25°C, Vd = +4,5V Pads: B, C, F = GND (High current configuration)

Symbol	Parameter	Min	Typ	Max	Unit
NF	Noise figure		3	4.5	dB
G	Gain	17	20		dB
IP3	3rd order intercept point (Pout/tone=-5dBm) 18-26GHz	18	20		dBm

ESD Protections: Electrostatic discharge sensitive device observe handling precautions!

Electrical Characteristics (low current configuration)

Tamb = +25°C, Vd = +4.5V, pads: B, D, E = GND

Symbol	Parameter	Min	Typ	Max	Unit
Fop	Operating frequency range	18		30	GHz
G	Gain	16.5	19.5		dB
ΔG	Gain flatness		± 2	± 2.5	dB
NF	Noise figure		3	4.5	dB
IS11I	Input return loss		-5	-2	dB
IS22I	Ouput return loss		-7	-2.5	dB
IP3	3rd order intercept point (Pout/tone=-5dBm) 18-26GHz	16.5	18.5		dBm
P1dB	Output power at 1dB gain compression	9.0	10.5		dBm
Id	Drain bias current		65		mA

These values are representative of onboard measurements as defined on the drawing in paragraph "Evaluation mother board:". Performances can be optimized thanks to external matching (refer to the "Sub-band enhancement" paragraph).

Electrical Characteristics (high current configuration)

Tamb = +25°C, Vd = +4,5V, pads: B, C, F = GND

Symbol	Parameter	Min	Typ	Max	Unit
Fop	Operating frequency range	18		30	GHz
G	Gain	17	20		dB
ΔG	Gain flatness		± 2	± 2.5	dB
NF	Noise figure		3	4.5	dB
IS11I	Input return loss		-5	-2	dB
IS22I	Ouput return loss		-7	-2.5	dB
IP3	3rd order intercept point (Pout/tone=-5dBm) 18-26GHz	18	20		dBm
P1dB	Output power at 1dB gain compression	12	13.5		dBm
Id	Drain bias current		85		mA

Absolute Maximum Ratings ⁽¹⁾T_{amb} = +25°C

Symbol	Parameter	Values	Unit
V _d	Drain bias voltage	5	V
P _{in}	Maximum input power overdrive	+10	dBm
R _{th_BDE}	Thermal Resistance channel to ground paddle (2)	130	°C/W
R _{th_BCF}	Thermal Resistance channel to ground paddle (2)	120	°C/W
T _{op}	Operating temperature range	-40 to +85	°C
T _{stg}	Storage temperature range	-55 to +125	°C

(1) Operation of this device above any of these parameters may cause permanent damage.

(2) Thermal resistance for T_{amb} = +85°C and a T_{j max} = +175°C.

Device thermal performances

All the figures given in this section are obtained assuming that the QFN device is cooled down only by conduction through the package thermal pad (no convection mode considered).

The temperature is monitored at the package back-side interface (T_{case}) as shown below. The system maximum temperature must be adjusted in order to guarantee that T_{case} remains below than the maximum value specified in the next table. So, the system PCB must be designed to comply with this requirement.

A derating must be applied on the dissipated power if the T_{case} temperature can not be maintained below than the maximum temperature specified (see the curve $P_{diss. Max}$) in order to guarantee the nominal device life time (MTTF).

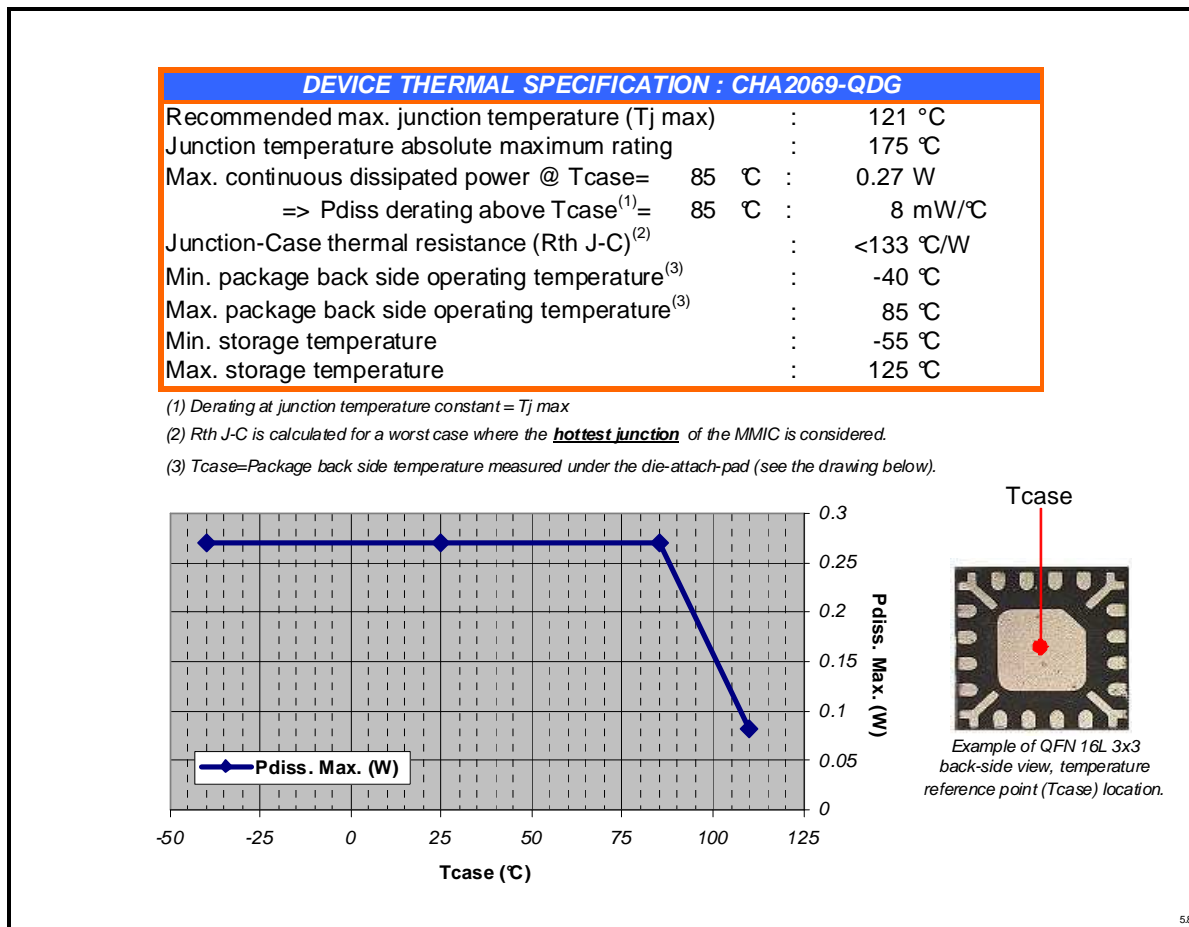

Typical Package Sij parameters for low current configuration

Tamb = +25°C, Vd = +4,5V Pads: B, D, E grounded

F (GHz)	S11	S11	S12	S12	S21	S21	S22	S22
	dB	∠°	dB	∠°	dB	∠°	dB	∠°
2	-0.1	-58.7	-95.2	-85.6	-57.5	-2.4	-0.6	-148.4
3	-0.1	-89.3	-68.8	63.3	-77.6	-24.4	-0.9	157.1
4	-0.1	-123.5	-63.2	93.4	-52.9	62.8	-0.9	112.4
5	-0.2	-160.8	-62.9	47.1	-37.4	145.3	-1.3	72.0
6	-0.4	156.1	-58.1	11.4	-18.1	93.6	-1.7	39.9
7	-0.6	107.6	-67.5	-59.7	-4.4	28.0	-2.0	8.4
8	-1.2	58.9	-68.1	93.7	4.4	-52.1	-3.0	-20.2
9	-1.8	13.5	-61.6	-9.2	9.6	-122.4	-3.9	-38.6
10	-2.8	-26.1	-60.0	-42.6	14.7	176.1	-4.4	-69.5
11	-4.0	-58.0	-55.1	171.8	19.0	109.4	-8.3	-92.5
12	-5.7	-89.1	-53.4	87.2	21.7	41.3	-13.4	-92.8
13	-8.8	-122.0	-49.6	14.1	23.3	-24.1	-17.0	-67.1
14	-15.8	-173.9	-50.5	-42.8	24.0	-86.8	-12.6	-36.0
15	-17.4	24.9	-48.2	-120.3	23.5	-146.2	-8.3	-46.7
16	-10.9	-20.6	-48.3	171.6	22.4	162.0	-6.3	-65.3
17	-8.5	-47.1	-49.6	133.4	21.5	116.9	-5.9	-85.2
18	-7.0	-65.5	-47.3	121.9	20.9	75.8	-5.9	-99.8
19	-6.2	-82.8	-44.9	92.5	20.8	34.2	-6.1	-116.0
20	-5.8	-98.4	-42.5	57.3	20.7	-6.5	-7.2	-130.1
21	-4.9	-110.8	-43.2	20.1	20.9	-48.3	-7.9	-137.3
22	-4.7	-125.9	-45.3	14.9	20.9	-90.8	-9.2	-142.4
23	-4.3	-138.7	-43.3	-0.5	20.9	-135.3	-8.7	-139.3
24	-3.9	-152.2	-43.7	-14.8	20.4	178.7	-7.6	-141.9
25	-3.8	-163.2	-44.2	-36.7	19.6	135.8	-6.3	-148.5
26	-3.3	-173.7	-45.4	-48.5	18.8	92.8	-4.4	-156.9
27	-3.0	175.5	-46.5	-43.8	17.8	52.7	-3.7	-169.0
28	-2.5	166.4	-43.7	-45.2	17.1	13.2	-3.0	-179.9
29	-2.5	155.4	-43.2	-59.5	16.8	-26.3	-2.7	171.2
30	-2.8	146.3	-42.0	-81.7	17.3	-69.6	-2.7	161.4
31	-3.9	144.4	-46.4	-112.7	18.0	-123.9	-2.6	156.1
32	-2.8	154.3	-47.9	-148.6	17.2	168.4	-2.5	150.5

The Sij measurement calibration planes are defined in the paragraph "Definition of the Sij reference planes".

Typical Package Sij parameters for high current configuration

Tamb = +25°C, Vd = +4,5V Pads: B, C, F grounded

F (GHz)	S11	S11	S12	S12	S21	S21	S22	S22
	dB	/°	dB	/°	dB	/°	dB	/°
2	-0.1	-58.5	-92.2	81.8	-57.9	0.4	-0.7	-146.6
3	-0.1	-88.9	-67.1	55.2	-69.1	-41.4	-1.1	159.3
4	-0.1	-122.6	-62.8	100.3	-51.5	77.3	-1.0	114.1
5	-0.2	-159.2	-63.0	51.4	-37.2	145.1	-1.5	73.0
6	-0.4	158.4	-56.6	15.4	-17.7	97.4	-1.9	40.1
7	-0.7	110.4	-64.5	-49.7	-3.8	31.4	-2.2	8.3
8	-1.3	60.8	-67.3	88.2	5.3	-49.4	-3.4	-21.8
9	-1.8	13.6	-61.5	-7.6	10.6	-120.9	-4.6	-40.0
10	-2.9	-27.8	-59.6	-45.7	15.6	177.2	-4.8	-68.3
11	-4.0	-60.9	-54.4	176.7	19.9	110.8	-8.5	-89.9
12	-5.6	-92.1	-53.9	99.3	22.7	43.0	-12.5	-90.4
13	-8.5	-123.1	-50.6	22.2	24.2	-22.2	-16.3	-76.8
14	-14.6	-169.0	-52.1	-32.8	25.1	-84.9	-13.8	-40.8
15	-19.5	26.2	-50.3	-120.6	24.8	-145.6	-8.9	-46.4
16	-11.3	-23.8	-49.4	165.3	23.6	161.3	-6.5	-65.0
17	-8.5	-49.1	-50.9	132.8	22.6	115.2	-6.0	-86.1
18	-6.9	-67.5	-46.9	122.6	21.8	73.8	-5.8	-101.6
19	-6.1	-83.9	-44.9	88.3	21.5	32.7	-6.1	-119.7
20	-5.6	-97.1	-43.0	53.7	21.2	-7.8	-7.0	-134.2
21	-4.6	-109.1	-44.1	21.4	21.3	-48.7	-7.6	-144.5
22	-4.4	-123.2	-45.4	19.8	21.3	-90.2	-9.0	-153.5
23	-4.1	-135.7	-43.9	7.2	21.4	-133.4	-9.4	-152.7
24	-3.7	-149.8	-43.4	-10.0	21.0	-178.9	-8.8	-151.9
25	-3.8	-162.0	-44.3	-34.6	20.3	138.4	-7.6	-155.6
26	-3.5	-173.4	-44.5	-42.2	19.7	94.7	-5.5	-161.7
27	-3.3	174.4	-47.4	-45.9	18.7	53.4	-4.5	-172.3
28	-3.0	164.8	-44.8	-39.0	18.0	12.8	-3.6	177.3
29	-2.9	153.8	-43.6	-43.1	17.6	-27.1	-3.0	168.4
30	-2.9	143.4	-41.7	-66.2	18.0	-70.8	-2.6	158.1
31	-3.8	138.2	-44.6	-91.4	18.4	-123.8	-2.6	150.7
32	-2.7	145.3	-49.9	-140.7	17.8	169.5	-2.6	144.6

The Sij measurement calibration planes are defined in the paragraph “Definition of the Sij reference planes”.

Typical Measured Performances

Tamb = +25°C, Vd = +4.5V

Measurements are given in the package access plans, using the proposed land pattern and board given in the paragraph "Evaluation mother board:".

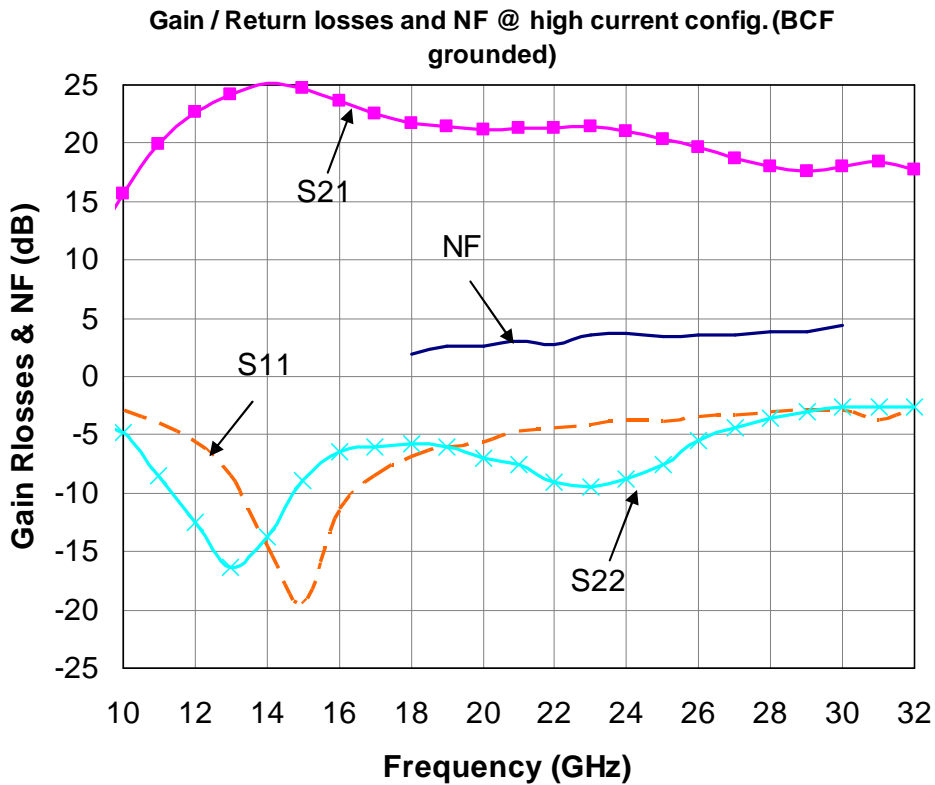
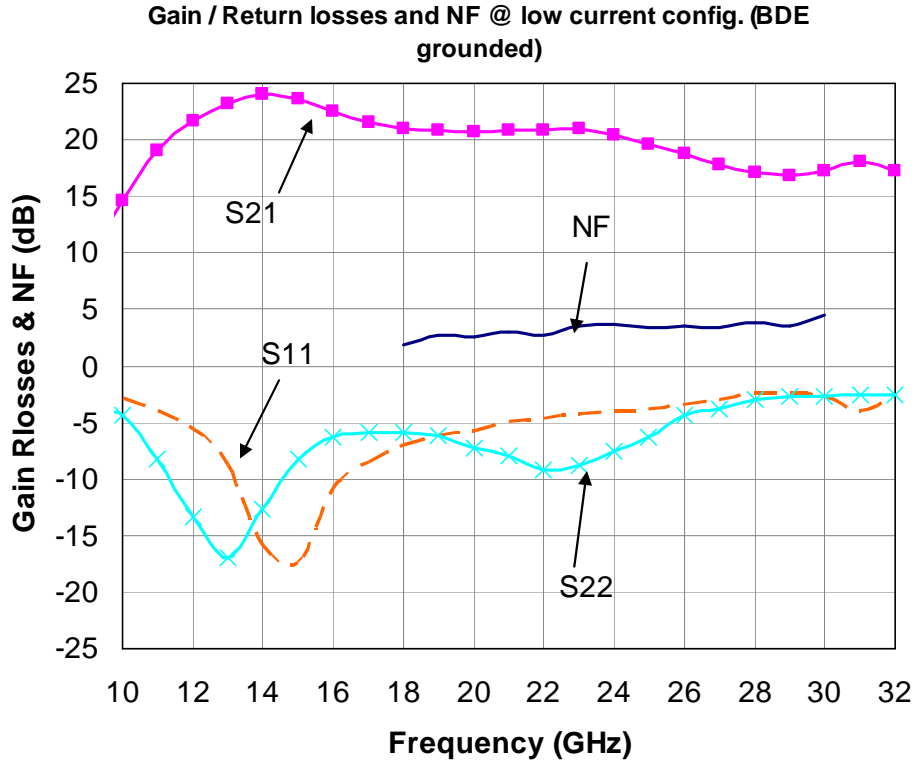

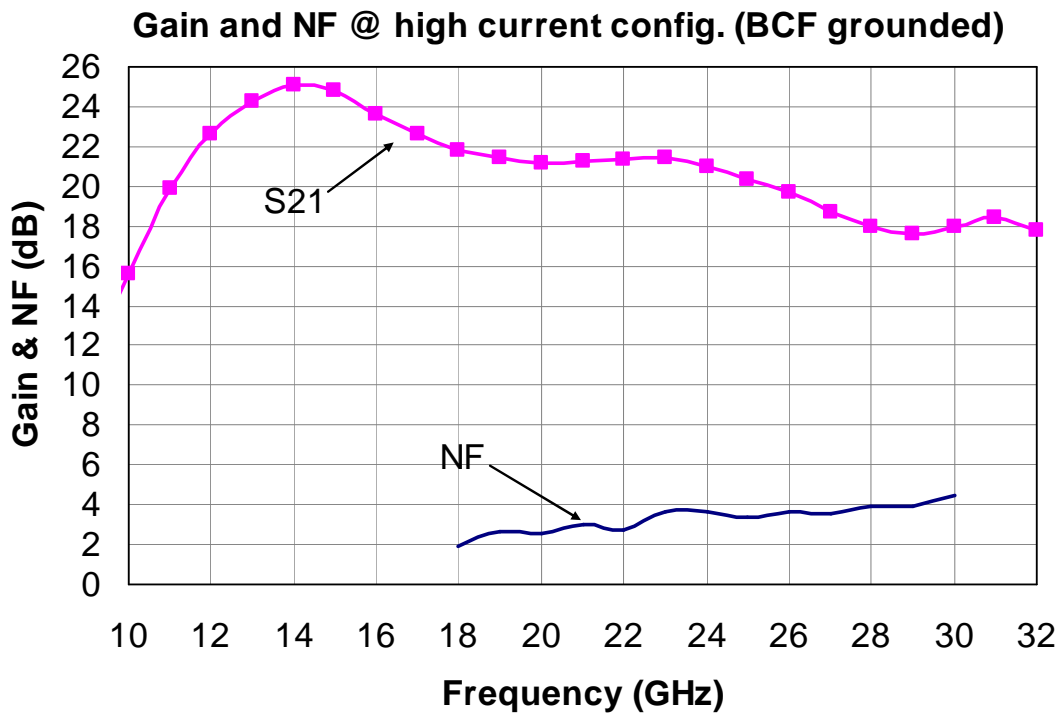
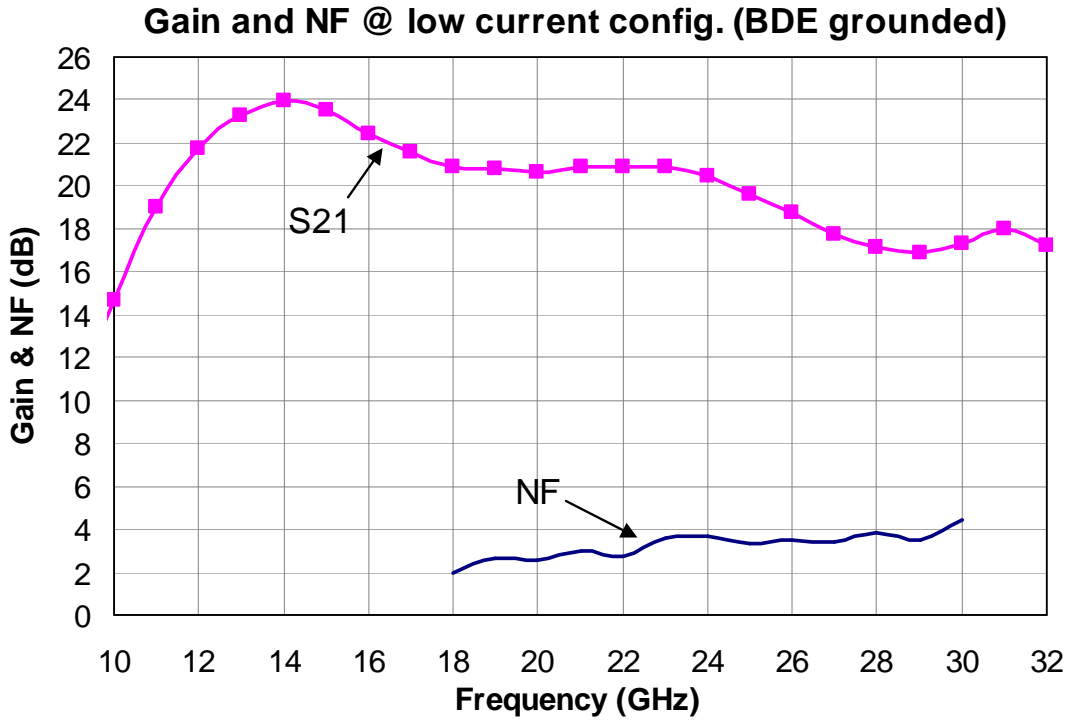

Typical Measured Performances

Tamb = +25°C, Vd = +4.5V

Measurements are given in the connectors' access plans, using the proposed land pattern and board given in the paragraph "Evaluation mother board:".
 For these measurements, losses due to board are not deembedded.

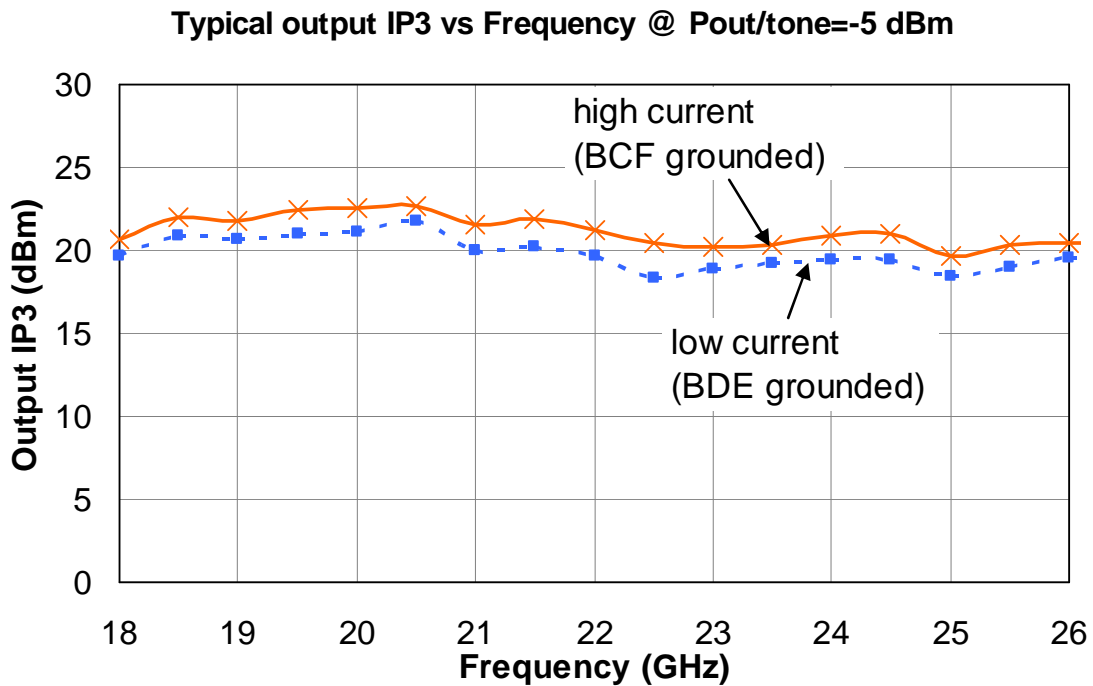
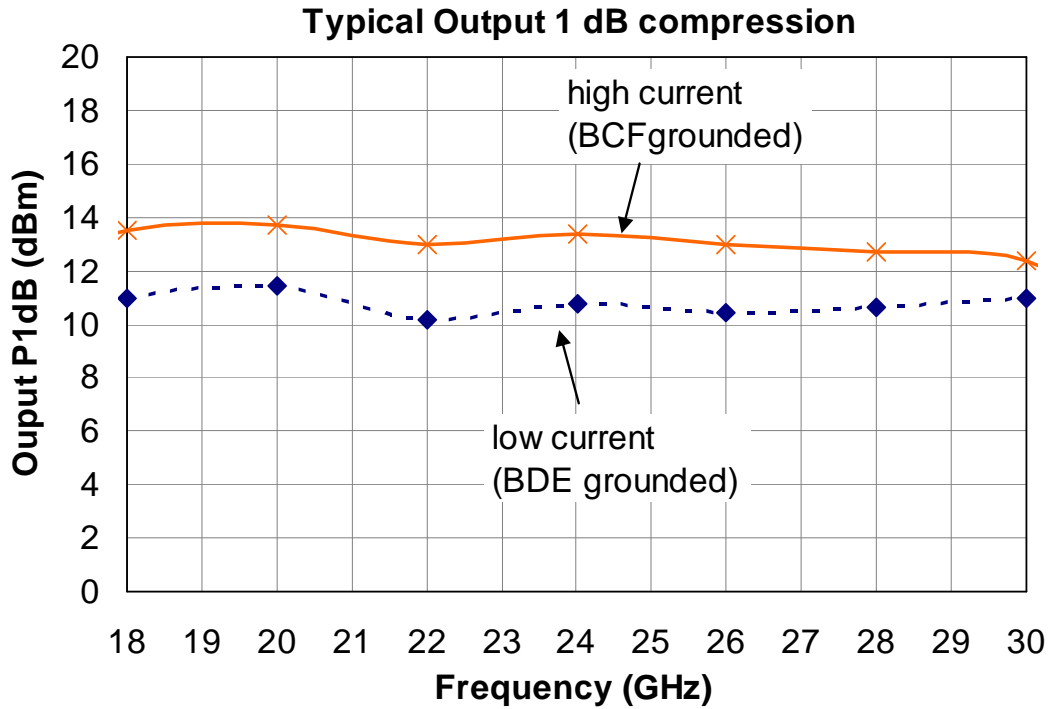

Typical C/I3 vs Frequency @ Pout/tone=-5 dBm

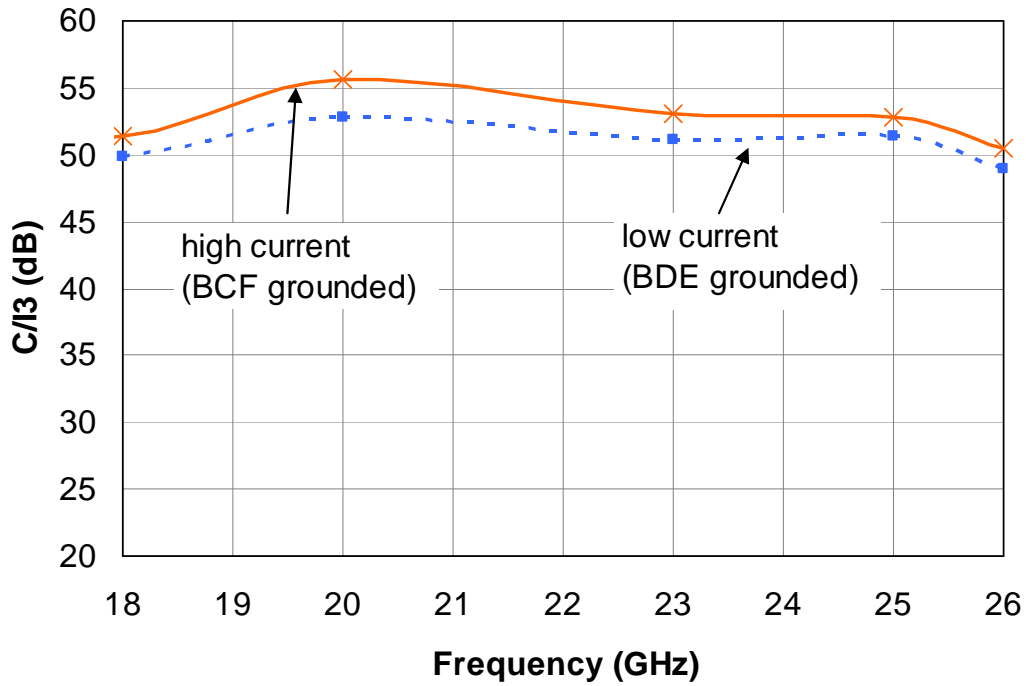

Typical C/I3 vs Pout/tone @ low current configuration (BDE grounded)

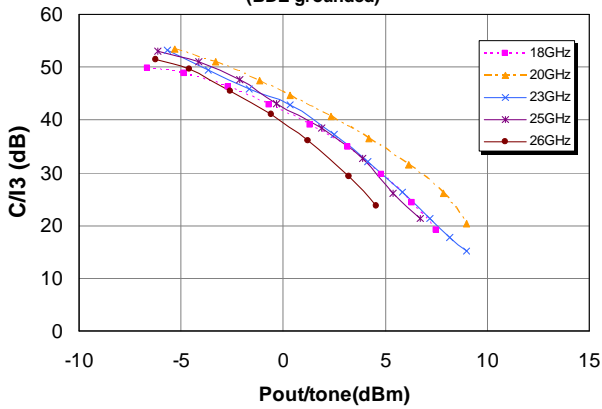

Typical C/I3 vs Pout/tone @ high current configuration (BCF grounded)

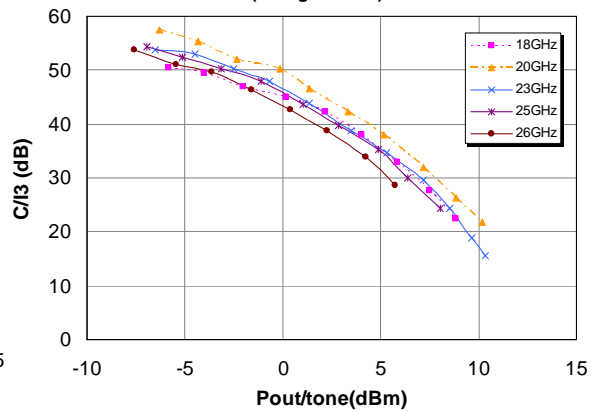

Package outline ⁽¹⁾

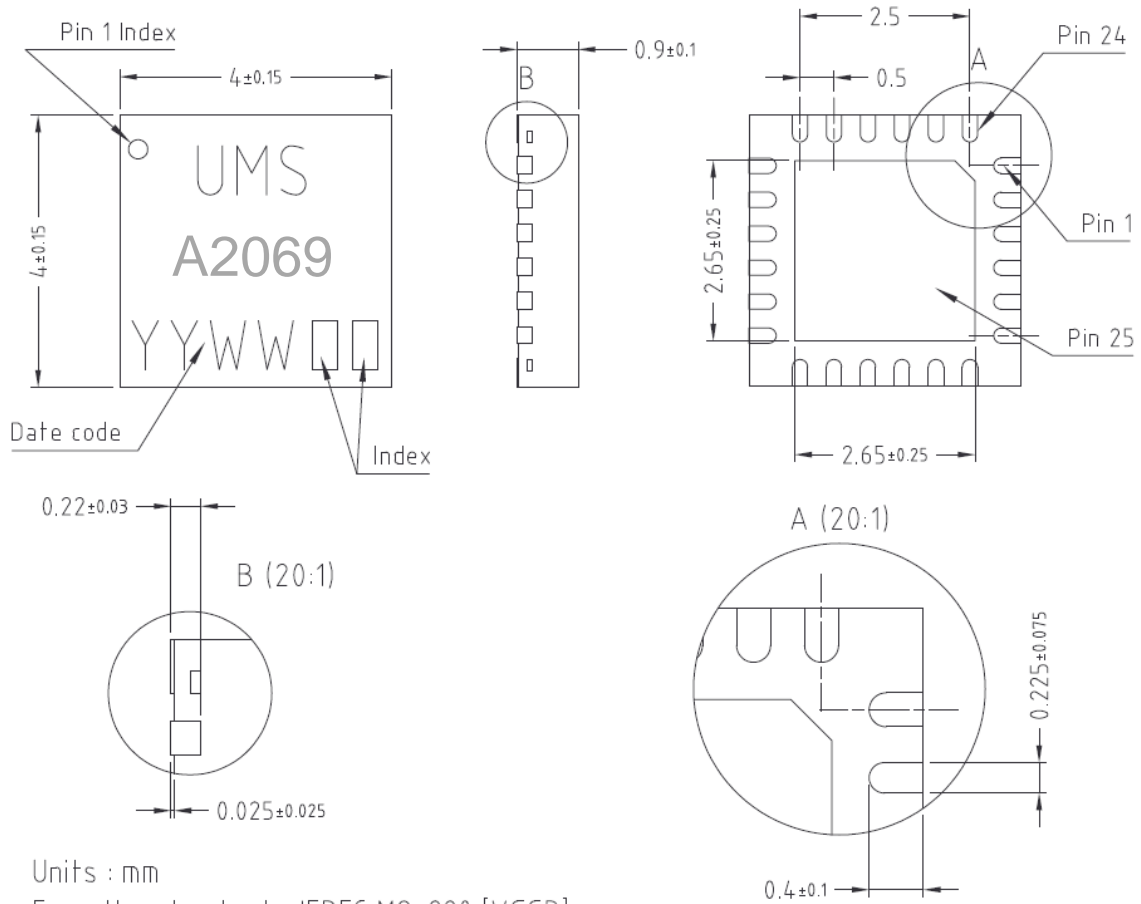

Units : mm
 From the standard : JEDEC MO-220 [VGGD]
 Matt tin, Lead free (Green)

Matt tin, Lead Free (Green)	1- Nc	13- Nc
Units mm	2- Nc	14- Gnd
From the standard JEDEC MO-220 (VGGD)	3- Gnd	15- RF OUT
	4- RF IN	16- Gnd
25- GND	5- Gnd	17- Nc
	6- Nc	18- Nc
	7- B	19- Vd
	8- C	20- Vd
	9- D	21- Vg3
	10- Nc	22- Vg2
	11- E	23- Vg1
	12- F	24- Nc

⁽¹⁾The package outline drawing included to this data-sheet is given for indication. Refer to the application note AN0017 available at <http://www.ums-gaas.com> for exact package dimensions.

It is strongly recommended to ground all pins marked "Gnd" through the PCB board. Ensure that the PCB board is designed to provide the best possible ground to the package.

Definition of the Sij reference planes

The reference planes used for Sij measurements given above are symmetrical from the symmetrical axis of the package (see drawing beside). The input and output reference planes are located at 3.18mm offset (input wise and output wise respectively) from this axis. Then, the given Sij parameters incorporate the land pattern of the evaluation motherboard recommended in paragraph "Evaluation mother board:".

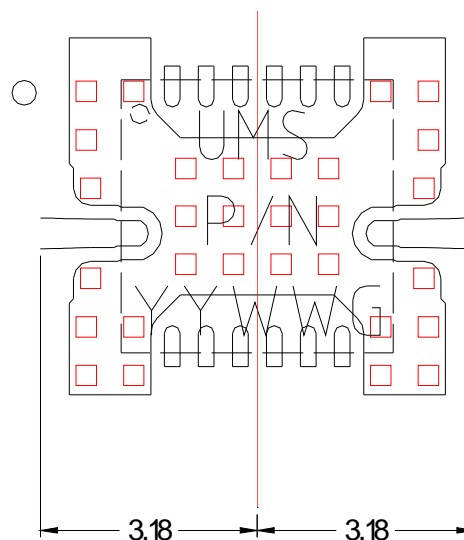

Recommended package footprint

Refer to the application note AN0017 available at <http://www.ums-gaas.com> for package footprint recommendations and exact package dimensions.

SMD mounting procedure

The SMD leadless package has been designed for high volume surface mount PCB assembly process. The dimensions and footprint required for the PCB (motherboard) are given in the drawings above.

Recommended environmental management

Refer to the application note AN0019 available at <http://www.ums-gaas.com> for environmental data on UMS package products.

Recommended ESD management

Refer to the application note AN0020 available at <http://www.ums-gaas.com> for ESD sensitivity and handling recommendations for the UMS package products.

Packaged part biasing options

This circuit is self-biased, and flexibility is provided by the access to number of pads. the internal DC electrical schematic is given in order to use these pads in a safe way.

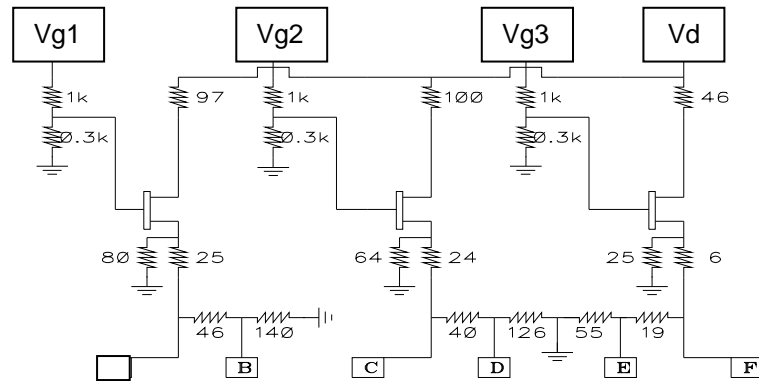

The two requirements are:

N°1: Not exceed $V_d = 3.5\text{V}$ (internal Drain to Source voltage).

N°2: Not biased in such a way that V_{g_i} becomes positive. (Internal Gate to Source voltage)

We propose two standard biasing:

Low Noise and low consumption:

$V_d = 4.5\text{V}$ and B, D, E grounded.

All the other pads non connected (NC).

$I_d = 65\text{mA}$ & $P_{out-1\text{dB}} = 10.5\text{dBm}$ Typical.

(Equivalent to B, C, D, E, F: non connected and $V_d=4.5\text{V}$; $V_{g1}=V_{g2}=V_{g3}=+1\text{V}$).

Low Noise and higher output power

$V_d = 4.5\text{V}$ and B, C, F grounded.

All the other pads non connected (NC).

$I_d = 85\text{mA}$ & $P_{out-1\text{dB}} = 13.5\text{dBm}$ Typical..

Evaluation mother board:

- Compatible with the proposed footprint.
- Based on typically Ro4003 / 8mils or equivalent.
- Using a microstrip to coplanar transition to access the package.
- Recommended for the implementation of this product on a module board.
- Decoupling capacitors of 10nF \pm 10% are recommended for all DC accesses.
- (See application note AN0017 for details).

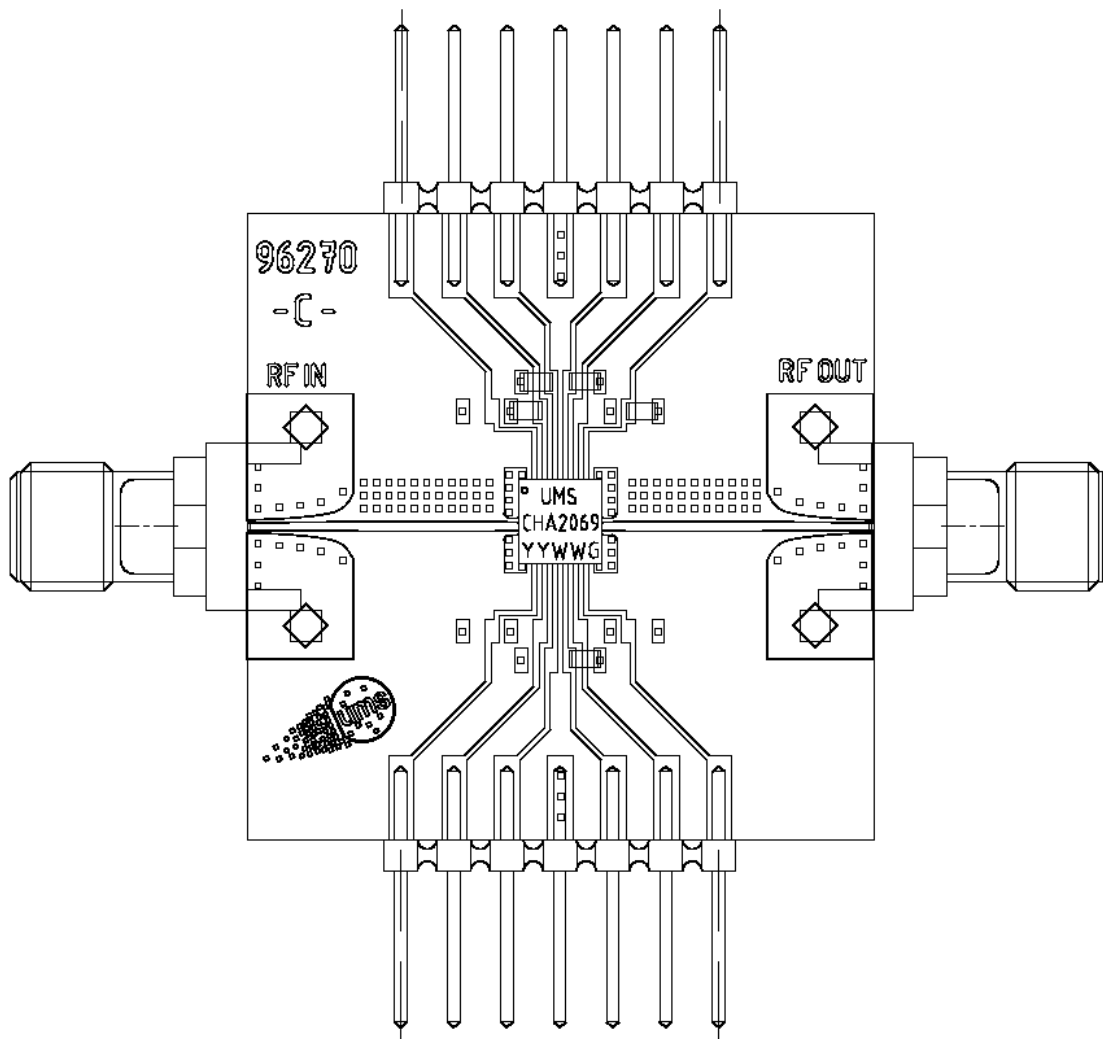

Sub-band enhancement

The performances of this product can be enhanced in sub-bands using external matching components such as very simple combination of micro-strip stubs.

For some sub-bands, matching networks have been implemented and some typical results are shown below. For further details see the application notes listed below.

Matched Sub-band	Application note reference
17-20GHz	AN0010_CHA2069QDG_17-20
21-24GHz	AN0011_CHA2069QDG_21-24
24.5-26.5GHz	AN0012_CHA2069QDG_24_5-26_5

Of course, based on the S_{ij} matrix given previously, more accurate, or dedicated frequency boards may be derived.

The following graphs show S parameters obtained thanks to the external matching networks described in the application notes quoted in the list above.

**Typical S parameters with matching network for the 17-20GHz band
Config. High current (BCFgrounded)**

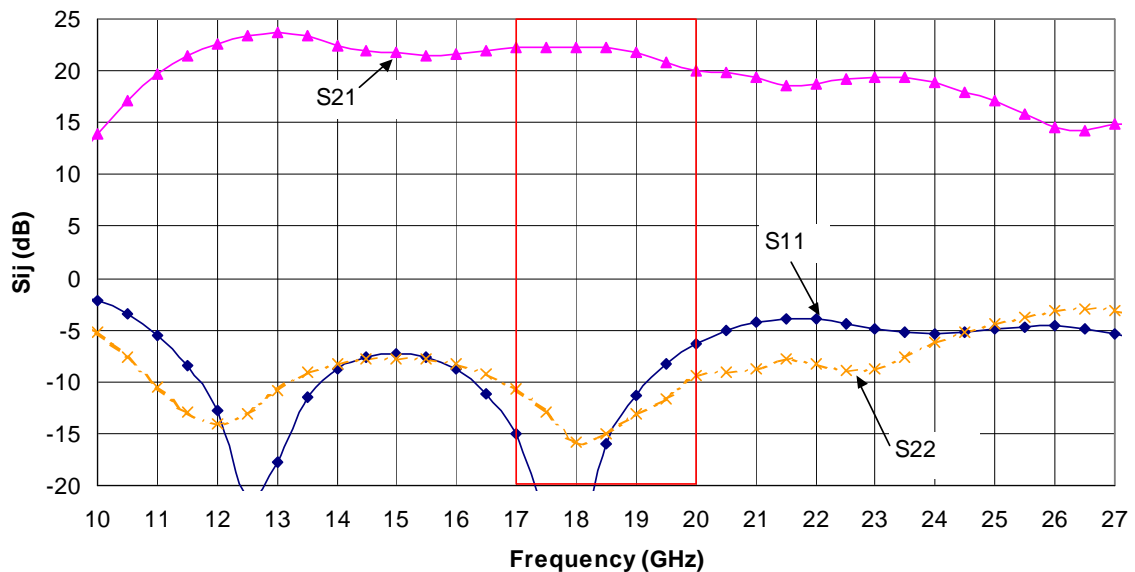

Typical S parameters with matching network for the 21-24GHz band
 Config. High current (BCFgrounded)

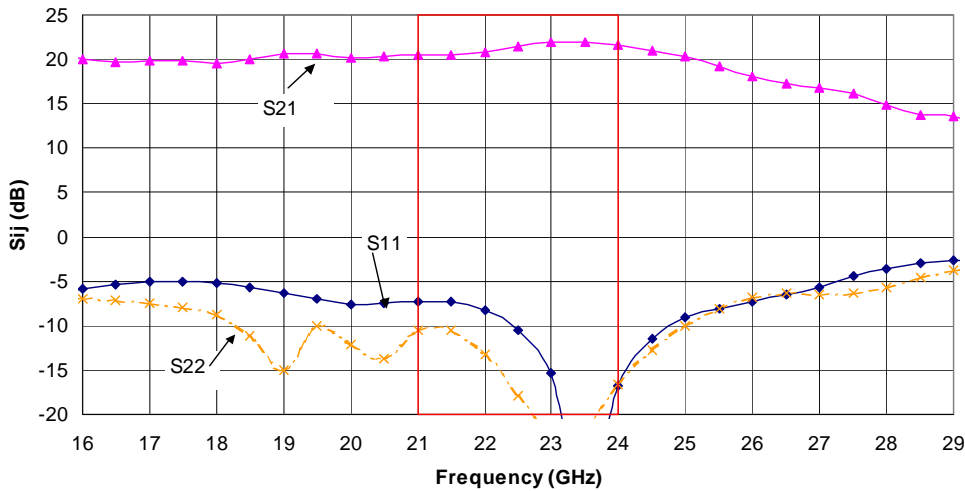

Typical S parameters with matching network
 for the 24.5-26.5GHz band
 Config. High current (BCFgrounded)

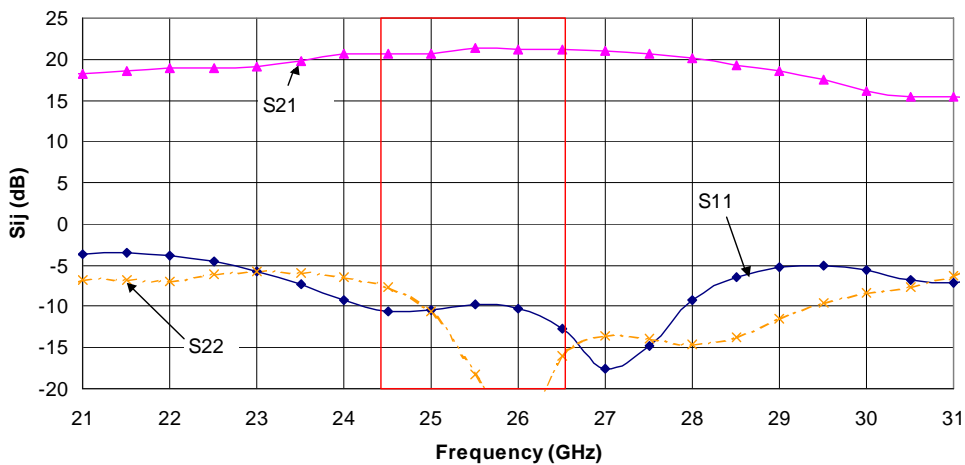

Ordering Information

QFN 4x4 RoHS compliant package: CHA2069-QDG/XY
 Stick: XY = 20 Tape & reel: XY = 21

Information furnished is believed to be accurate and reliable. However **United Monolithic Semiconductors S.A.S.** assumes no responsibility for the consequences of use of such information nor for any infringement of patents or other rights of third parties which may result from its use. No license is granted by implication or otherwise under any patent or patent rights of **United Monolithic Semiconductors S.A.S.** Specifications mentioned in this publication are subject to change without notice. This publication supersedes and replaces all information previously supplied. **United Monolithic Semiconductors S.A.S.** products are not authorised for use as critical components in life support devices or systems without express written approval from **United Monolithic Semiconductors S.A.S.**