

7-13GHz Low Noise Amplifier

GaAs Monolithic Microwave IC

Description

The CHA2063a is a two-stage wide band monolithic low noise amplifier.

The circuit is manufactured with a PM-HEMT process : 0.25 μ m gate length, via holes through the substrate, air bridges and electron beam gate lithography.

It is supplied in chip form or in an hermetic leadless ceramic package.

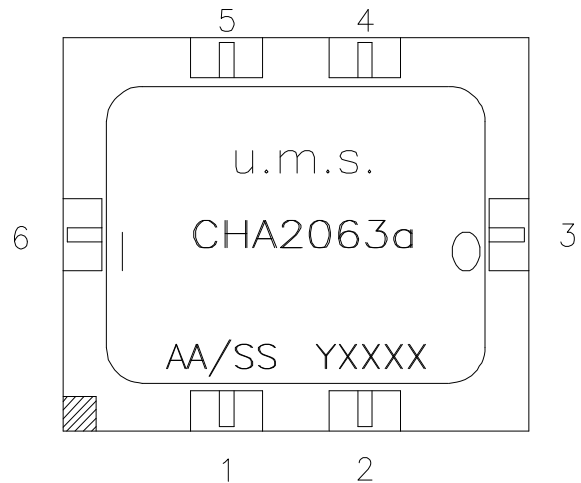

Main Features

- Broad band performance 7-13GHz
- 2.0dB noise figure, 8-13GHz
- 19dB gain
- Low DC power consumption, 40mA
- 18dBm 3rd order intercept point
- Chip size : 1,52 x 1,27 x 0.1mm

Pin Out

- 1 - NC
- 2 - NC
- 3 - RF output
- 4 - NC
- 5 - Vdd
- 6 - RF input

Main Characteristics

Tamb = +25°C, package form

Symbol	Parameter	Min	Typ	Max	Unit
NF	Noise figure, 7-8GHz		2.5	3.0	dB
	Noise figure, 8-13GHz		2.0	2.5	
G	Gain	16	19		dB
Δ G	Gain flatness		± 2.0		dB

ESD Protections : Electrostatic discharge sensitive device observe handling precautions !

Electrical Characteristics Package form

Tamb = +25°C, Vd = +4V

Symbol	Parameter	Test Conditions	Min	Typ	Max	Unit
Fop	Operating frequency range		7		13	Ghz
G	Gain		16	19		dB
ΔG	Gain flatness			± 2		dB
NF	Noise figure 7-8 Ghz			2.5	3.0	dB
	Noise figure 8-13 GHz			2.0	2.5	
VSWRin	Input VSWR			2.0:1	2.5:1	
VSWRout	Ouput VSWR			2.0:1	2.5:1	
P1dB	Output power at 1dB gain compression F=10 GHz			8		dBm
IP3	3rd order intercept point			18		dBm
Id	Drain bias current			40	60	mA

Absolute Maximum Ratings

Tamb = +25°C

Symbol	Parameter	Values	Unit
Vd	Drain bias voltage (3)	5.0	V
Pin	Maximum peak input power overdrive (2)	+15	dBm
Top	Operating temperature range	-40 to +85	°C
Tstg	Storage temperature range	-55 to +125	°C

(1) Operation of this device above anyone of these paramaters may cause permanent damage.

(2) Duration < 1s.

(3)See chip biasing option page 9/10

Electrical Characteristics

Chip form

Tamb = +25°C, Vd = +4V

Symbol	Parameter	Test Conditions	Min	Typ	Max	Unit
Fop	Operating frequency range	(1)	7		12	Ghz
G	Gain		17	19		dB
ΔG	Gain flatness			± 2		dB
NF	Noise figure 7-8 Ghz			2.5	3.0	dB
	Noise figure 8-12 GHz			2.0	2.5	
VSWRin	Input VSWR	(1)		2.0:1	3.0:1	
VSWRout	Ouput VSWR	(1)		2.0:1	3.0:1	
P1dB	Output power at 1dB gain compression F=10 GHz			8		dBm
IP3	3rd order intercept point			18		dBm
Id	Drain bias current			40	80	mA

(1) These values are representative of on-wafer measurements that are made without bonding wires at the RF ports. When the chip is connected with typical 0.3 nH input and output bonding wires, the indicated parameter values are close to those of the CHA2063a packaged product.

Typical on Wafer Scattering Parameters

Tamb = +25°C

Vd = 4.0V ; Vg1 = Vg2 = +2.5Volt ; Id = 40mA (A,B,C,D & E not connected)

(see chip biasing option page 9/10)

Freq GHz	S11 dB	S11 °	S12 dB	S12 °	S21 dB	S21 °	S22 dB	S22 °
5.00	-0.86	-91.7	--65.97	-63.6	6.08	-175.1	-7.99	-131.3
5.50	-1.66	-109.6	-57.28	-77.7	11.49	152.4	-9.91	-139.3
6.00	-3.56	-131.8	-50.70	-105.2	16.03	113.4	-11.62	-143.8
6.50	-7.75	-153.2	-46.25	-137.6	18.99	69.3	-12.74	-150.7
7.00	-14.77	-159.2	-43.76	-167.7	20.39	27.7	-14.62	-164.1
7.50	-21.16	-116.9	-42.21	166.7	20.79	-9.1	-18.09	-179.8
8.00	-19.40	-79.1	-41.19	145.2	20.89	-40.9	-24.49	160.0
8.50	-16.83	-61.4	-40.39	127.8	20.76	-69.6	-34.60	38.5
9.00	-14.68	-53.7	-39.78	111.7	20.45	-95.4	-23.38	-9.1
9.50	-12.52	-52.6	-39.31	96.9	20.16	-119.5	-18.53	-23.3
10.00	-10.61	-57.4	-38.85	83.9	19.79	-141.8	-15.76	-31.8
10.50	-9.31	-65.5	-38.51	72.6	19.36	-162.9	-13.58	-40.2
11.00	-8.38	-74.2	-38.14	62.0	18.85	176.6	-11.92	-48.5
11.50	-7.71	-83.7	-37.74	52.8	18.41	157.3	-10.67	-57.1
12.00	-7.26	-93.4	-37.17	44.1	17.94	138.1	-9.74	-65.8
12.50	-6.86	-103.8	-36.62	35.4	17.40	119.5	-9.01	-73.5
13.00	-6.57	-114.6	-35.91	27.3	16.84	101.6	-8.54	-81.7
13.50	-6.34	-126.4	-35.11	18.2	16.26	83.8	-8.21	-88.8
14.00	-6.18	-139.4	-34.27	8.5	15.65	66.5	-8.05	-95.7
14.50	-6.16	-153.5	-33.41	-1.9	15.01	49.1	-8.03	-101.7
15.00	-6.25	-169.0	-32.67	-13.3	14.35	31.7	-8.02	-106.9

Typical Results in package
Typical Response (In package Sij) :

Tamb = +25°C Vd = 4.0V ; ; Id = 40mA
 Gain slope : -0.015dB/°C Id slope : -0.025mA/°C

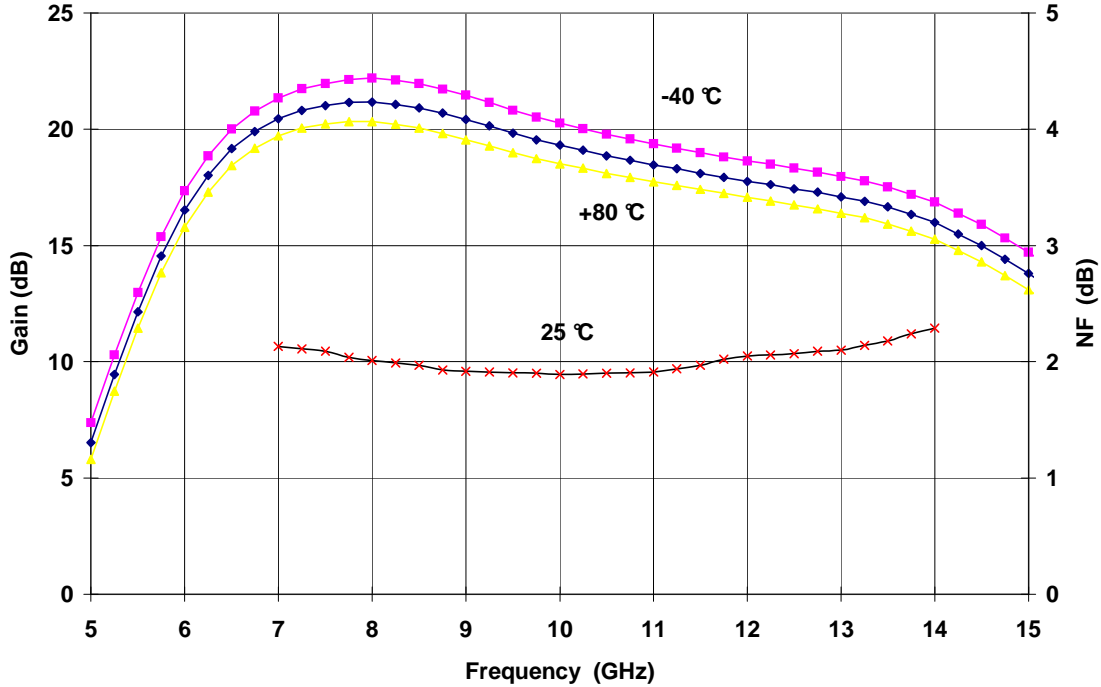

Typical Gain and Noise Figure measurements in package

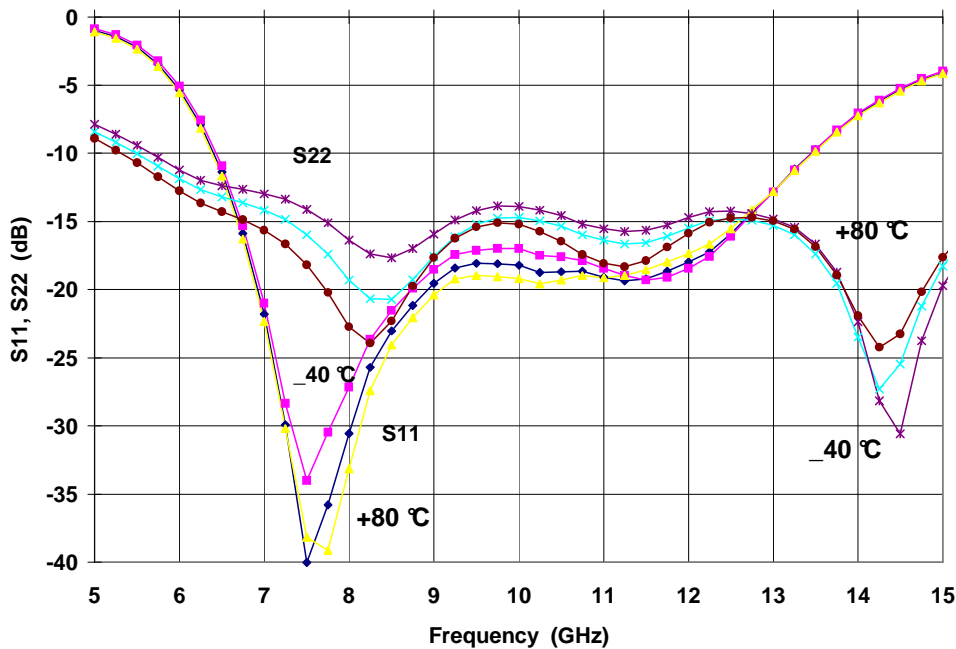

Typical Matching measurements in package.

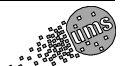

Typical Output Power measurements in package

Tamb = +25°C Vd = 4.0V ; Id = 40mA F=10 GHz

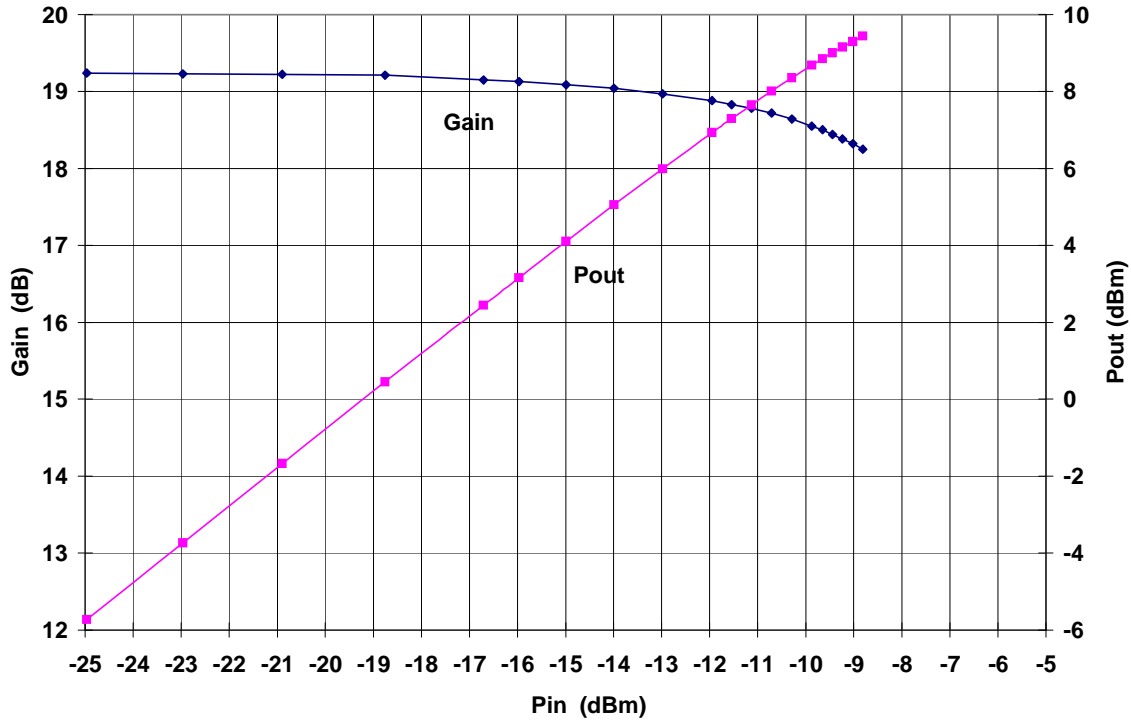

Typical Results in chip

Chip Typical Response (On wafer Sij) :

Tamb = +25°C

Vd = 4.0V ; Vg1 = Vg2 = +2.5Volt ; Id = 40mA (A,B,C,D & E not connected)

(see chip biasing option page 9/10)

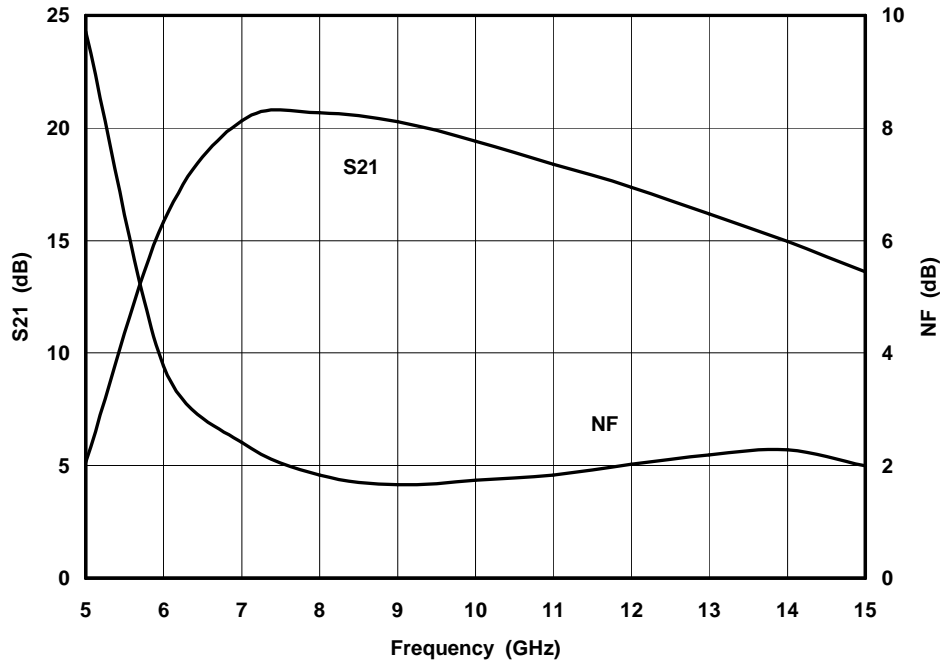

Typical Gain and Noise Figure measurements on wafer.

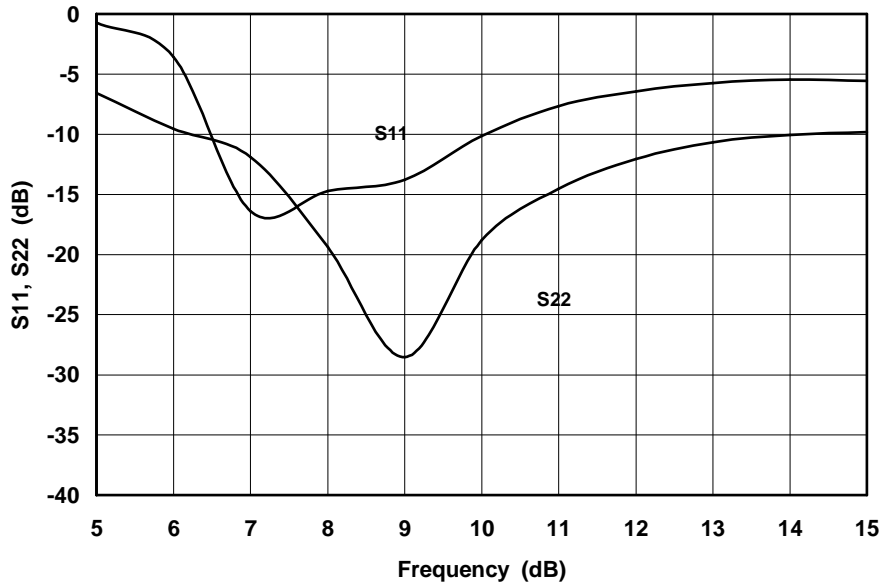

Typical Matching measurements on wafer.

Typical Chip Assembly

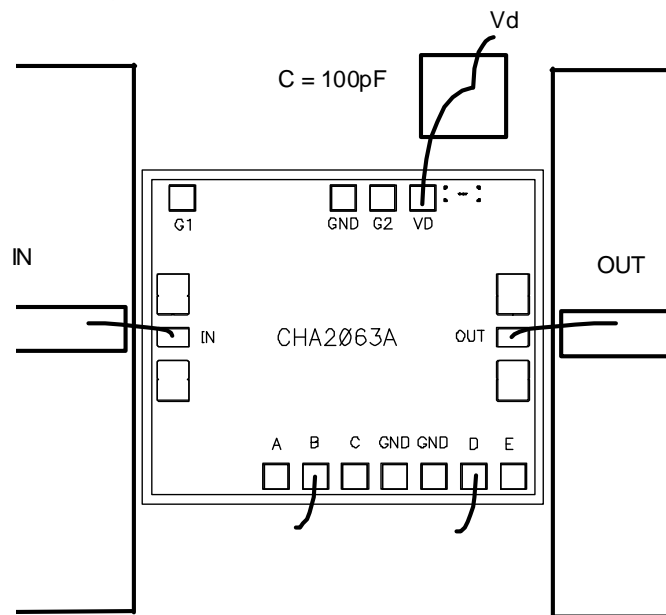

Chip Biasing options

This chip is self-biased, and flexibility is provided by the access to number of pads. the internal DC electrical schematic is given in order to use these pads in a safe way.

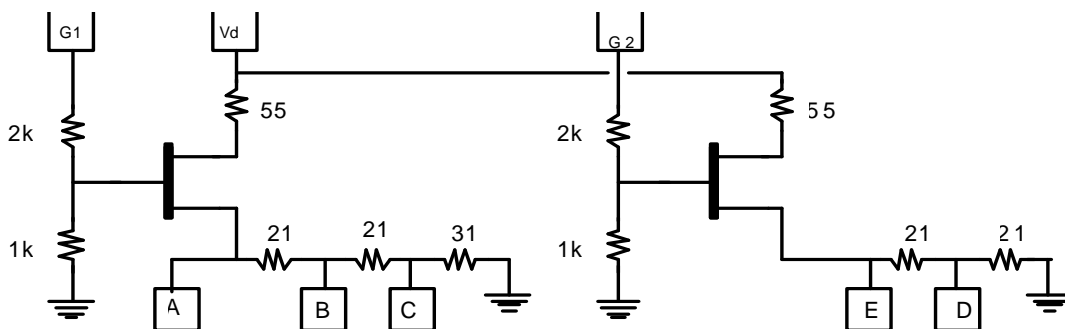

The two requirements are :

N°1 : Not exceed $V_{ds} = 3.5V$ (internal Drain to Source voltage).

N°2 : Biased in such a way to limit V_{gs} positive value (internal Gate to Source voltage).

We propose two standard biasing :

Low Noise and low consumption :

$V_d = 4V$ and B & D grounded.

All the other pads non connected (NC).

$I_{dd} = 40mA$ & $P_{out-1dB} = +8dBm$ Typical.

(Equivalent to A,B,C,D,E : NC and $V_d=4V$; $G1=+2.5V$; $G2=+2.5V$).

Low Noise and high output power :

$V_d = 5V$ and B & E grounded.

All the other pads non connected (NC).

$I_{dd} = 75mA$ & $P_{out-1dB} = +13dBm$ Typical.

(Equivalent to A,B,C,D,E : NC and $V_d=5V$; $G1=+2.5V$; $G2=+1.0V$).

Package Outline

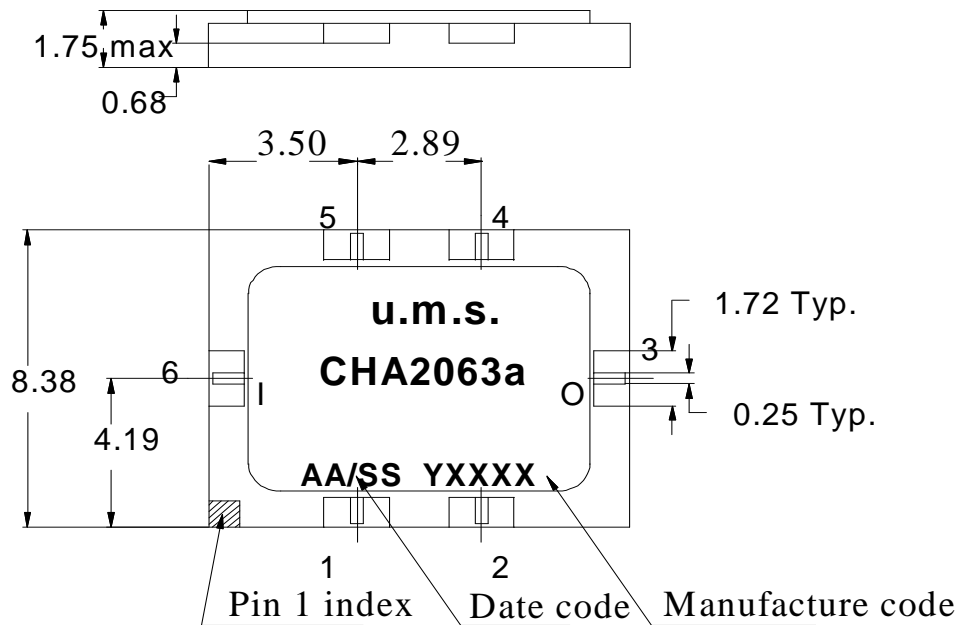

Unit : mm

General tolerance : ± 0.13

Ordering Information

Chip form : CHA2063a99F/00
 Package form : CHA2063aMAF/23

Information furnished is believed to be accurate and reliable. However **United Monolithic Semiconductors S.A.S.** assumes no responsibility for the consequences of use of such information nor for any infringement of patents or other rights of third parties which may result from its use. No license is granted by implication or otherwise under any patent or patent rights of **United Monolithic Semiconductors S.A.S.** Specifications mentioned in this publication are subject to change without notice. This publication supersedes and replaces all information previously supplied. **United Monolithic Semiconductors S.A.S.** products are not authorised for use as critical components in life support devices or systems without express written approval from **United Monolithic Semiconductors S.A.S.**