

7-12 GHz LNA

GaAs Monolithic Microwave IC in SMD leadless package

Description

The CHA2110-QDG is a monolithic two-stages wide band low noise amplifier. It is self-biased.

It is designed for a wide range of applications, from military to commercial communication systems.

The circuit is manufactured with a pHEMT process, 0.25 μ m gate length, via holes through the substrate, and air bridges.

It is supplied in RoHS compliant SMD package.

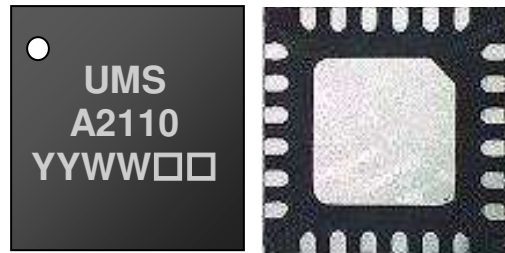

Main Features

- Broadband performances: 7-12GHz
- Linear gain: 19dB
- Noise Figure: 1.2dB
- Output power @ 1dB comp. : 10dBm
- DC bias: Vd=4V @ Id=45mA
- 24L-QFN4x4
- MSL1

Typical gain, input return losses, output return losses and Noise Figure (dB) versus frequency

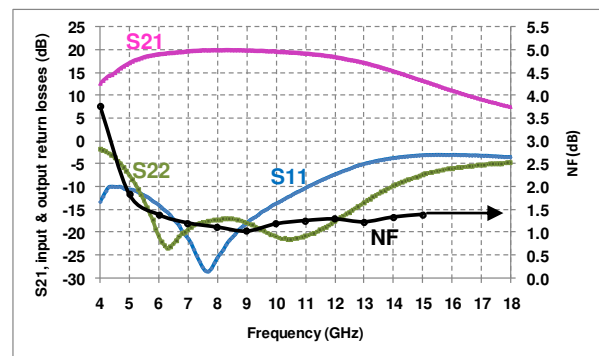

Main Electrical Characteristics

Tamb.= +25°C

Symbol	Parameter	Min	Typ	Max	Unit
Freq	Frequency range	7		12	GHz
Gain	Linear Gain		19		dB
NF	Noise Figure		1.2		dB
Pout	Output Power @1dB comp. (f=10GHz)		10		dBm

Electrical Characteristics

Tamb.= +25°C, Vd = +4V

Symbol	Parameter	Min	Typ	Max	Unit
Freq	Frequency range	7		12	GHz
Gain	Linear Gain		19		dB
NF	Noise Figure		1.2		dB
RL_in	Input return losses		-12		dB
RL_out	Output return losses		-12		dB
P1dB	Output power at 1dB comp (f=10GHz)		10		dBm
IP3	3 rd order interception point (f=10GHz)		21		dBm
Vd	Drain supply voltage (self biased)		4		V
Id	Drain supply current		45		mA

These values are representative of onboard measurements as defined on the drawing in paragraph "Evaluation mother board".

Absolute Maximum Ratings ⁽¹⁾T_{amb.} = +25 °C

Symbol	Parameter	Values	Unit
V _d	Drain bias voltage	5V	V
I _d	Drain bias current	70	mA
T _j	Junction temperature	175	°C
T _a	Operating temperature range	-40 to +85	°C
T _{stg}	Storage temperature range	-55 to +150	°C

⁽¹⁾ Operation of this device above anyone of these parameters may cause permanent damage.

Typical Bias ConditionsT_{amb.} = +25 °C

Symbol	Pad N°	Parameter	Values	Unit
V _d	VD1, VD2	Drain supply voltage	4	V

The circuit is self-biased.

Device thermal performances

All the figures given in this section are obtained assuming that the QFN device is cooled down only by conduction through the package thermal pad (no convection mode considered). The temperature is monitored at the package back-side interface (T_{case}) as shown below. The system maximum temperature must be adjusted in order to guarantee that T_{case} remains below than the maximum value specified in the next table. So, the system PCB must be designed to comply with this requirement.

A derating must be applied on the dissipated power if the T_{case} temperature can not be maintained below than the maximum temperature specified (see the curve $P_{diss. Max}$) in order to guarantee the nominal device life time (MTTF).

DEVICE THERMAL SPECIFICATION : CHA2110-QDG		
Recommended max. junction temperature (T_j max)	:	110 °C
Junction temperature absolute maximum rating	:	175 °C
Max. continuous dissipated power ($P_{diss. Max.}$)	:	0.2 W
=> $P_{diss. Max.}$ derating above $T_{case}^{(1)} = 85$ °C	:	7 mW/°C
Junction-Case thermal resistance ($R_{th J-C}^{(2)}$)	:	<138 °C/W
Minimum T_{case} operating temperature ⁽³⁾	:	-40 °C
Maximum T_{case} operating temperature ⁽³⁾	:	85 °C
Minimum storage temperature	:	-55 °C
Maximum storage temperature	:	150 °C

(1) Derating at junction temperature constant = T_j max.

(2) $R_{th J-C}$ is calculated for a worst case considering the **hottest junction** of the MMIC and all the devices biased.

(3) T_{case} = Package back side temperature measured under the die-attach-pad (see the drawing below).

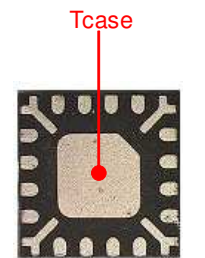
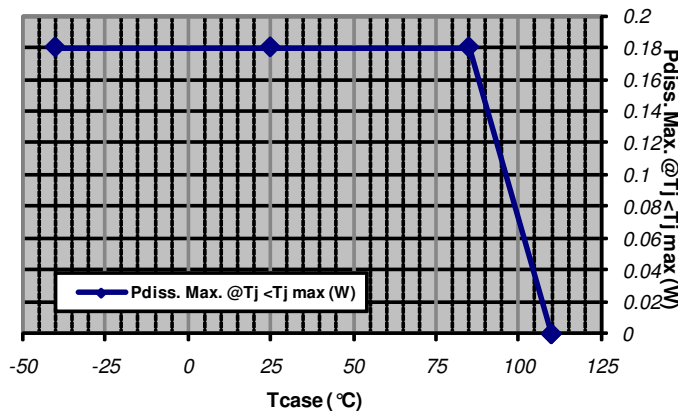

Example: QFN 16L 3x3
Location of temperature reference point (T_{case}) on package's bottom side

6.4

Typical Board Measurements

Tamb.= +25°C, Vd = +4V, Id = 45mA

Measurements are given in the [QFN's access plan.](#)

Linear Gain versus frequency

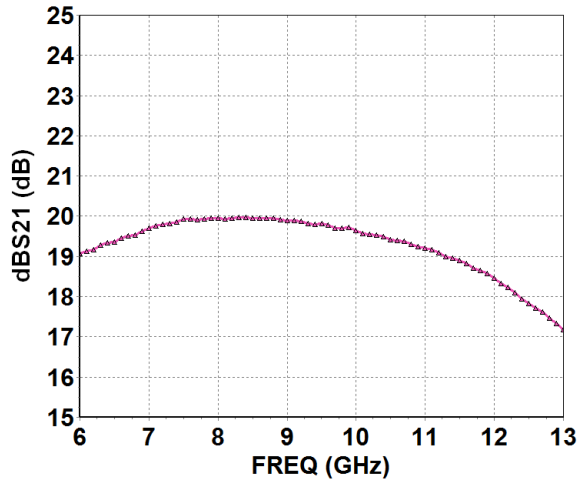

Input/Return losses versus frequency

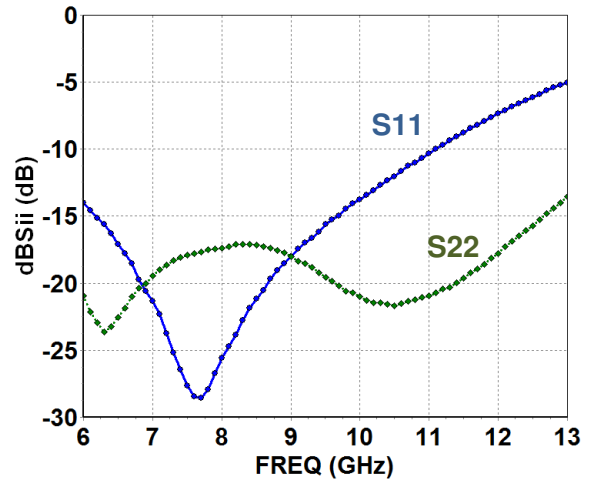

P1dB versus frequency

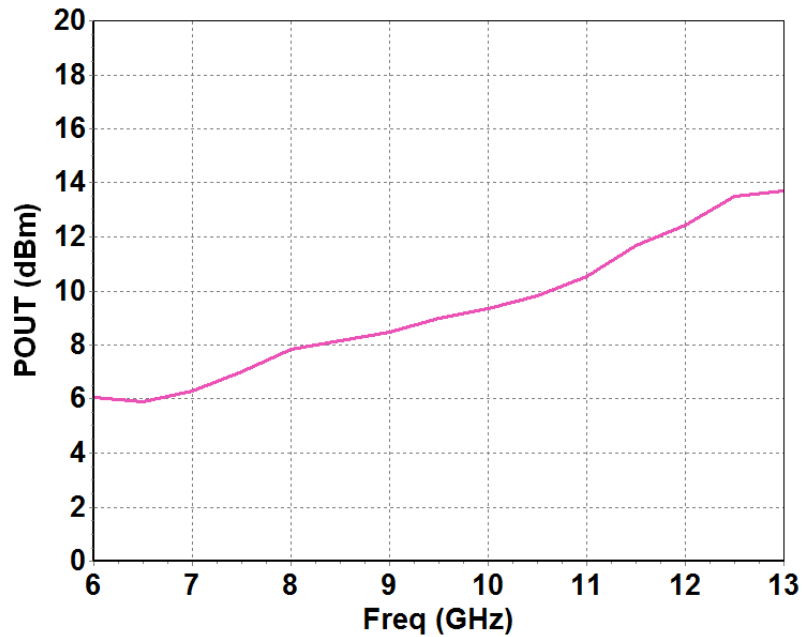

Typical Board Measurements

Tamb.= +25°C, Vd = +4V, Id = 45mA

Measurements are given in the [QFN's access plan](#).

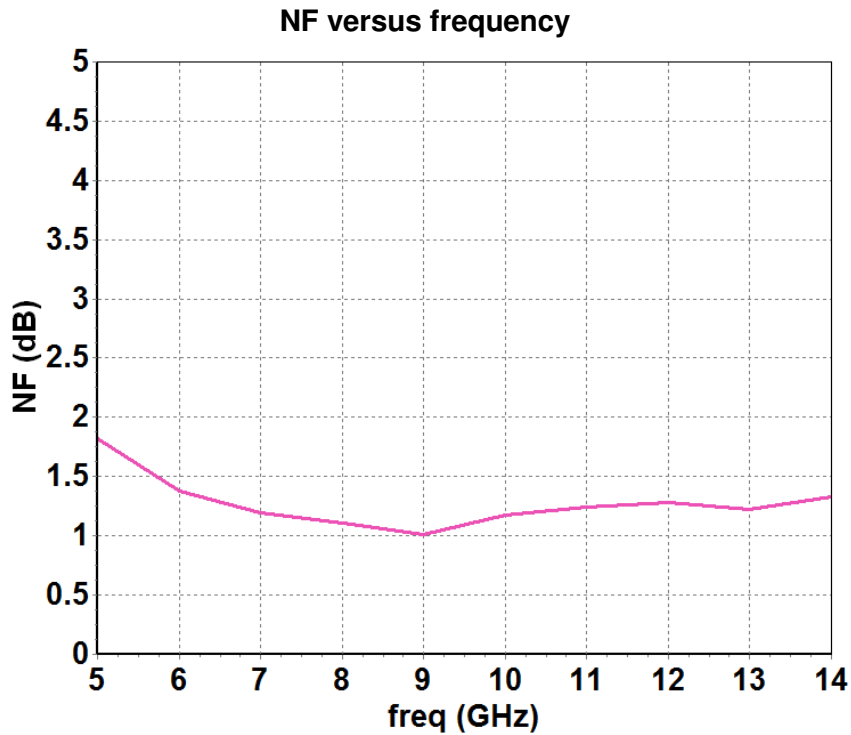

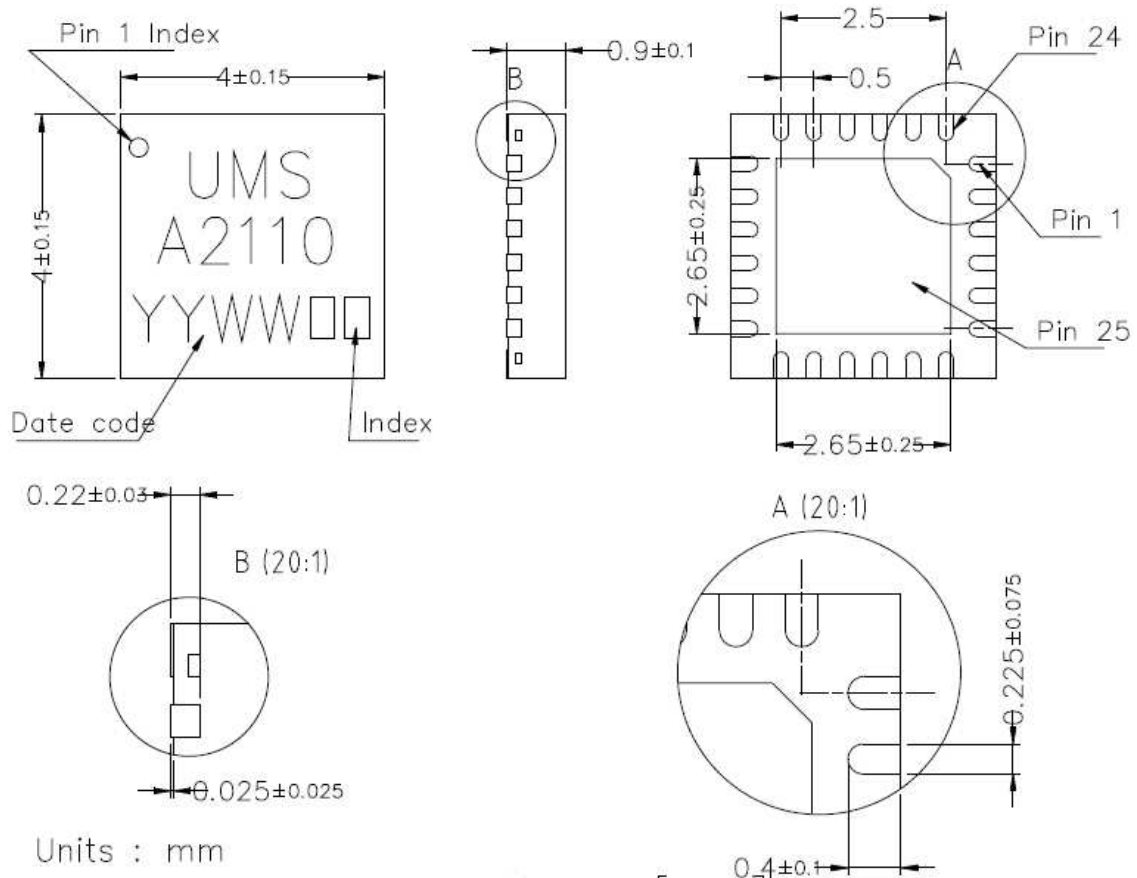
Package outline ⁽¹⁾

Units : mm

From the standard : JEDEC MO-220 [VGGD]

Matt tin, Lead free (Green)

Matt tin, Lead Free (Green)		1- Nc	11- 2B	21- VD2
Units :	mm	2- Gnd ⁽²⁾	12- Nc	22- VD1
From the standard :	JEDEC MO-220	3- Gnd ⁽²⁾	13- Gnd ⁽²⁾	23- Gnd ⁽²⁾
	(VGGD)	4- RF in	14- Gnd ⁽²⁾	24- Nc
	25- GND	5- Gnd ⁽²⁾	15- RF out	
		6- Gnd ⁽²⁾	16- Gnd ⁽²⁾	
		7- 1A	17- Gnd ⁽²⁾	
		8- 1B	18- Nc	
		9- Nc	19- Nc	
		10- 2A	20- Nc	

⁽¹⁾ The package outline drawing included to this data-sheet is given for indication. Refer to the application note AN0017 (<http://www.ums-gaas.com>) for exact package dimensions.

⁽²⁾ It is strongly recommended to ground all pins marked "Gnd" through the PCB board. Ensure that the PCB board is designed to provide the best possible ground to the package.

Definition of the Sij reference planes

The reference planes used for Sij measurements given above are symmetrical from the symmetrical axis of the package (see drawing beside). The input and output reference planes are located at 3.18mm offset (input wise and output wise respectively) from this axis. Then, the given Sij parameters incorporate the land pattern of the evaluation motherboard recommended in paragraph "Evaluation mother board".

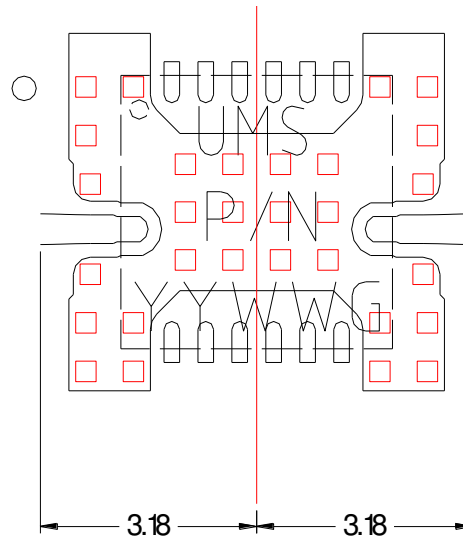

Evaluation mother board

- Compatible with the proposed footprint.
- Based on typically Ro4003 / 8mils or equivalent.
- Using a micro-strip to coplanar transition to access the package.
- Recommended for the implementation of this product on a module board.
- Decoupling capacitors of 100pF and 10nF $\pm 10\%$ are recommended for all VD1 and VD2 accesses.
- See application note AN0017 for details.

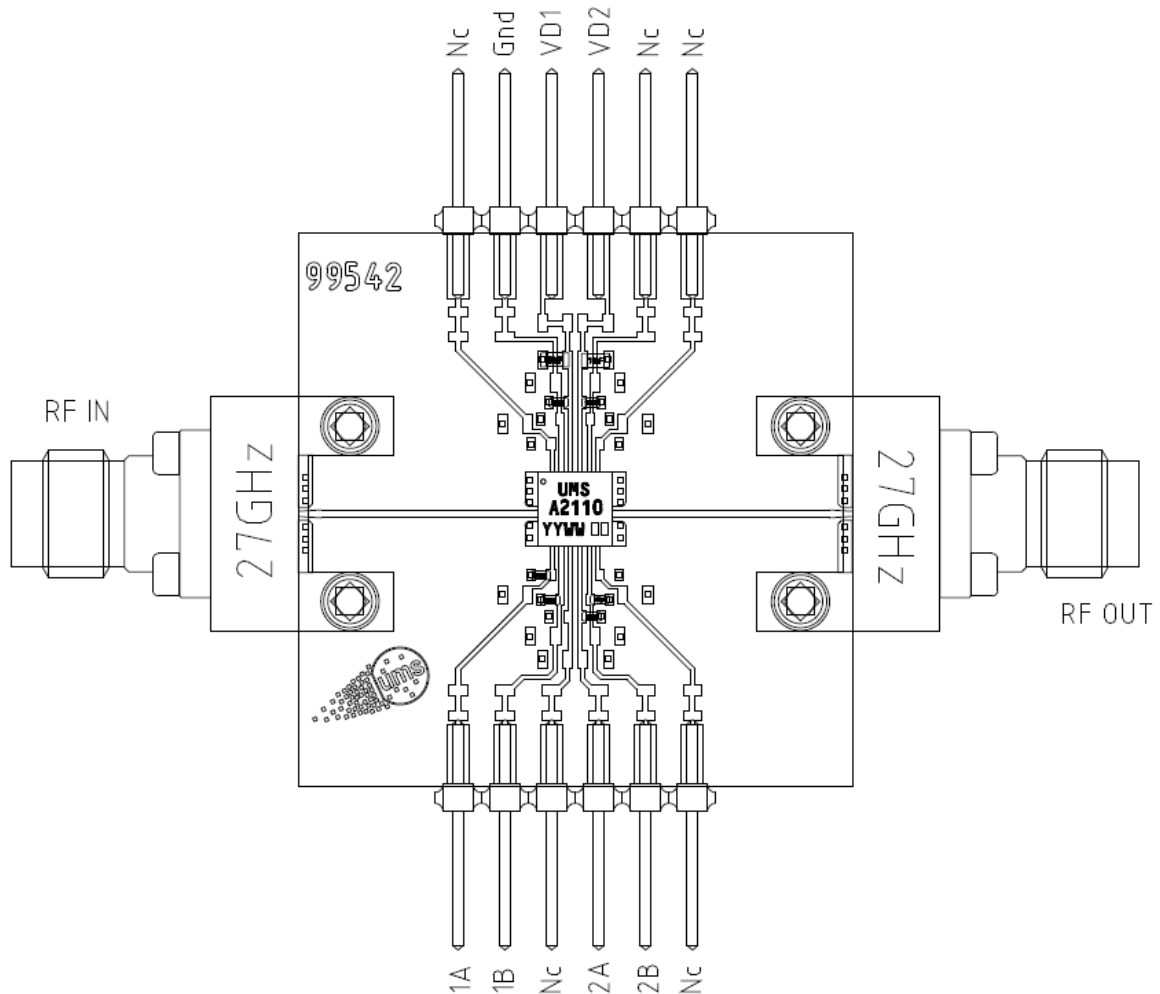

DC Schematic

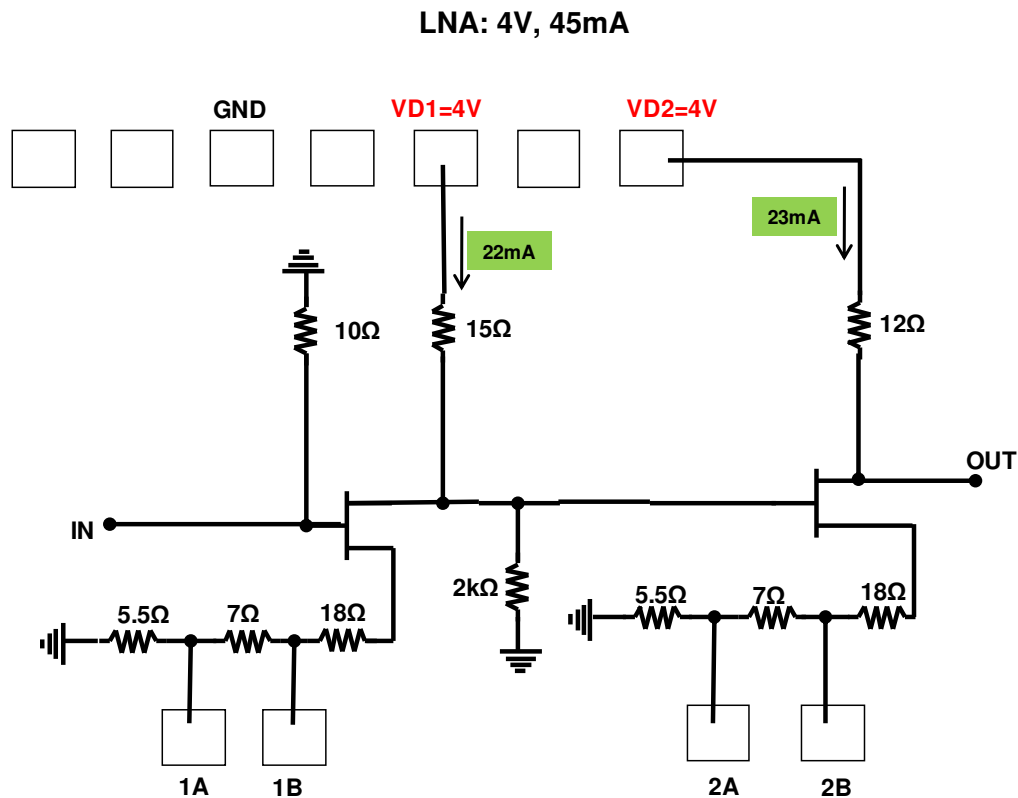

The requirement is :
Not exceed $V_{ds} = 3.5\text{V}$ (internal Drain to Source voltage).

We propose three standard biasing :
Low Noise and low consumption :

$V_d = 4\text{V}$.
The pads 1A, 1B, 2A and 2B are non connected (NC).
 $I_{dd} = 45\text{mA}$ & $P_{out-1dB} = +10\text{dBm}$ Typical
($f=10\text{GHz}$).

Low Noise and higher gain:

$V_d = 4\text{V}$ and 1A or 1B grounded.
All the other pads non connected (NC).
 $I_{dd} = 55\text{mA}$ & $P_{out-1dB} = +10\text{dBm}$ Typical
($f=10\text{GHz}$)

Low Noise and higher output power:

$V_d = 4\text{V}$ and 2A or 2B grounded.
All the other pads non connected (NC).
 $I_{dd} = 55\text{mA}$ & $P_{out-1dB} = +13\text{dBm}$ Typical
($f=10\text{GHz}$)

Notes

Recommended package footprint

Refer to the application note AN0017 available at <http://www.ums-gaas.com> for package footprint recommendations.

SMD mounting procedure

For the mounting process standard techniques involving solder paste and a suitable reflow process can be used. For further details, see application note AN0017.

Recommended environmental management

UMS products are compliant with the regulation in particular with the directives RoHS N°2011/65 and REACH N°1907/2006. More environmental data are available in the application note AN0019 also available at <http://www.ums-gaas.com>.

Recommended ESD management

Refer to the application note AN0020 available at <http://www.ums-gaas.com> for ESD sensitivity and handling recommendations for the UMS package products.

Ordering Information

QFN 4x4 package:

CHA2110-QDG/XY

Stick: XY = 20

Tape & reel: XY = 21

Information furnished is believed to be accurate and reliable. However **United Monolithic Semiconductors S.A.S.** assumes no responsibility for the consequences of use of such information nor for any infringement of patents or other rights of third parties which may result from its use. No license is granted by implication or otherwise under any patent or patent rights of **United Monolithic Semiconductors S.A.S.** Specifications mentioned in this publication are subject to change without notice. This publication supersedes and replaces all information previously supplied. **United Monolithic Semiconductors S.A.S.** products are not authorised for use as critical components in life support devices or systems without express written approval from **United Monolithic Semiconductors S.A.S.**