

X-band High Power Amplifier

GaAs Monolithic Microwave IC

Description

The CHA7115 is a monolithic three-stage GaAs high power amplifier designed for X-band applications.

The HPA provides typically 8W output power associated to 36% power added efficiency at 4dBcomp and a high robustness on mismatch load.

This device is manufactured using 0.25µm Power pHEMT process, including, via holes through the substrate and air bridges.

It is available in chip form.

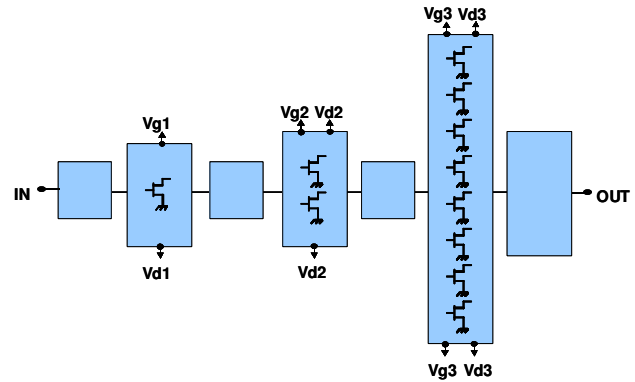

Main Features

- 0.25µm Power pHEMT Technology
- Frequency band: 8.5 – 11.5GHz
- Output power : 39dBm @ 4dBcomp
- High linear gain: > 27dB
- High PAE : 37% @ 4dBcomp
- Quiescent bias point: Vd=8V, Id=2.2A
- Chip size: 4.59 x 3.31 x 0.07mm

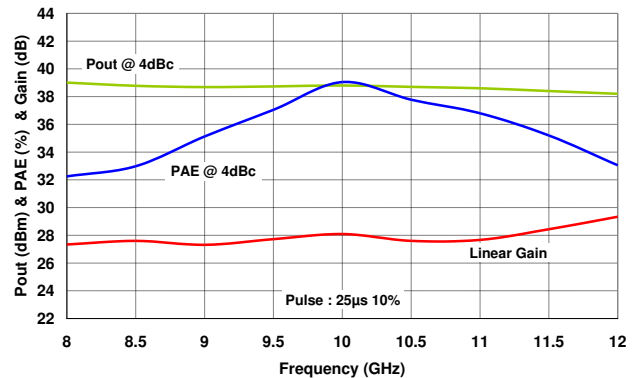

Main Characteristics

Vd = 8V, Id (Quiescent) = 2.2A, Drain Pulse width = 25µs, Duty cycle = 10%

Symbol	Parameter	Min	Typ	Max	Unit
Fop	Operating frequency range	8.5		11.5	GHz
PAE_4dB	Power added efficiency @4dBcomp @ 20 °C		37		%
P_4dB	Output power @ 4dBcomp @ 20 °C		39		dBm
G	Small signal gain @ 20 °C		27.5		dB

ESD Protections: Electrostatic discharge sensitive device. Observe handling precautions!

Electrical Characteristics on wafer

Tamb = 20°C, Vd = 8V, Id (Quiescent) = 2.2A, Drain Pulse width = 25µs, Duty cycle = 10%

Symbol	Parameter	Min	Typ	Max	Unit
Fop	Operating frequency	8.5		11.5	GHz
G	Small signal gain		27.5		dB
RLin	Input Return Loss		10		dB
RLout	Output Return Loss		12		dB
P_4dBc	Output power @ 4dBcomp (2)		39		dBm
PAE_4dB	Power Added Efficiency @ 4dBcomp		37		%
Id_4dB	Supply drain current @ 4dBcomp		2.6		A
Vd1, Vd2, Vd3	Drain supply voltage (2)		8		V
Id	Supply quiescent current (1)		2.2		A
Vg	Gate supply voltage		-1.4		V

(1) Parameter can be adjusted by tuning of Vg.

(2) 0.5V variation on Vd leads to around 0.4dB variation of the output power (impact on robustness see Maximum ratings).

Absolute Maximum Ratings (1)

Tamb = 20°C

Symbol	Parameter	Values	Unit
Cmp	Compression level (2)	6	dB
Vd	Supply voltage (3)	10	V
Id	Supply quiescent current	2.8	A
Id_sat	Supply current in saturation	4	A
Vg	Supply voltage	-0.8	V
Tj	Maximum junction temperature	175	°C
Tstg	Storage temperature range	-55 to +150	°C
Top	Operating temperature range	-40 to +80	°C

- (1) Operation of this device above anyone of these parameters may cause permanent damage.
- (2) For higher compression the level limit can be increased by decreasing the voltage Vd using the rate 0.5V/dBc.
- (3) Without RF input power.

Typical measured characteristics

Measurements on Wafer:

Vd = 8V, Id (Quiescent) = 2.2A, Drain Pulse width = 25µs, Duty cycle = 10%

Linear gain versus frequency

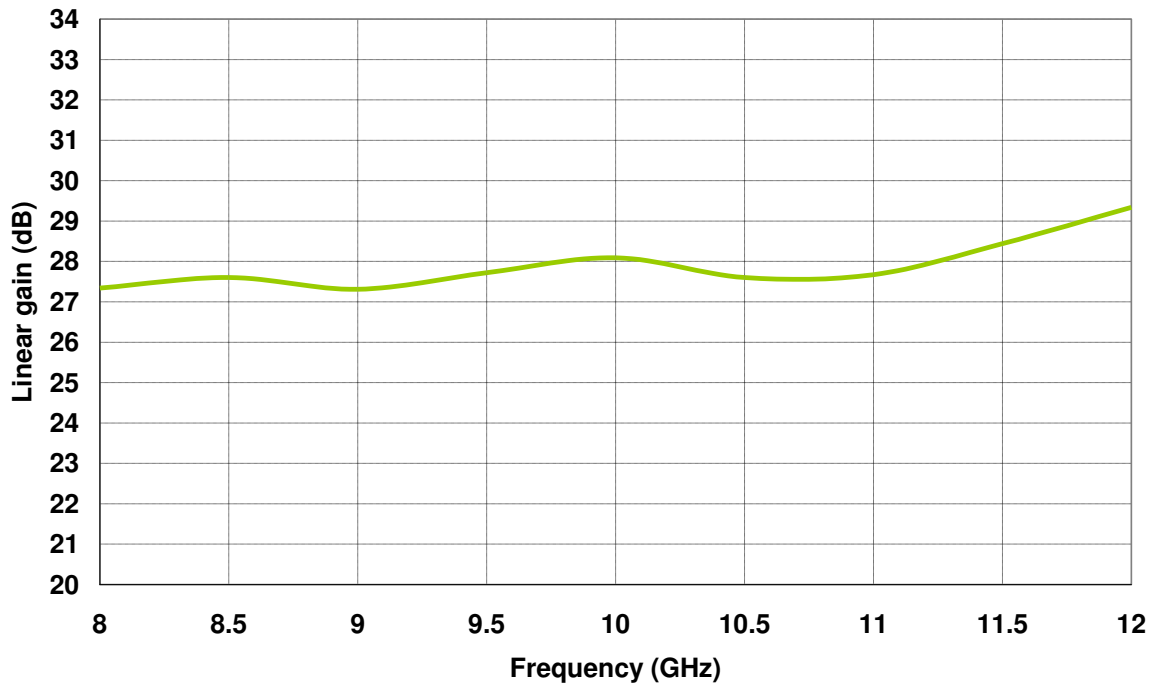

Output Power @ 4dBcomp versus frequency

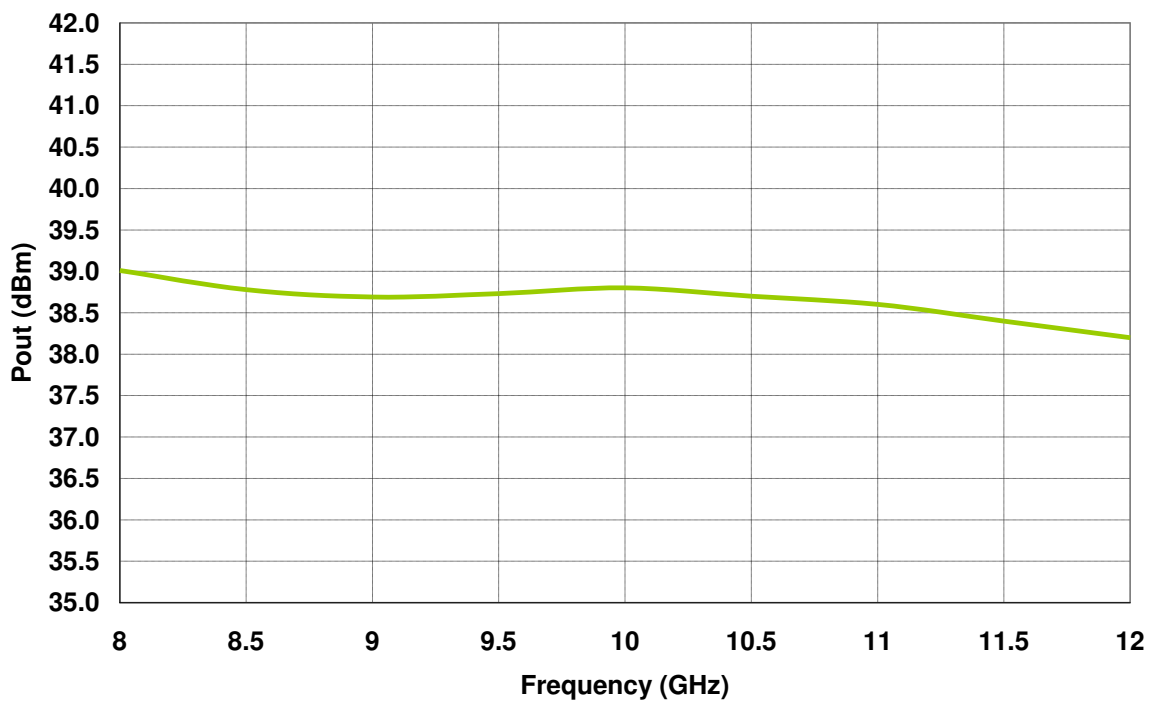

Power added efficiency @ 4dBcomp versus frequency

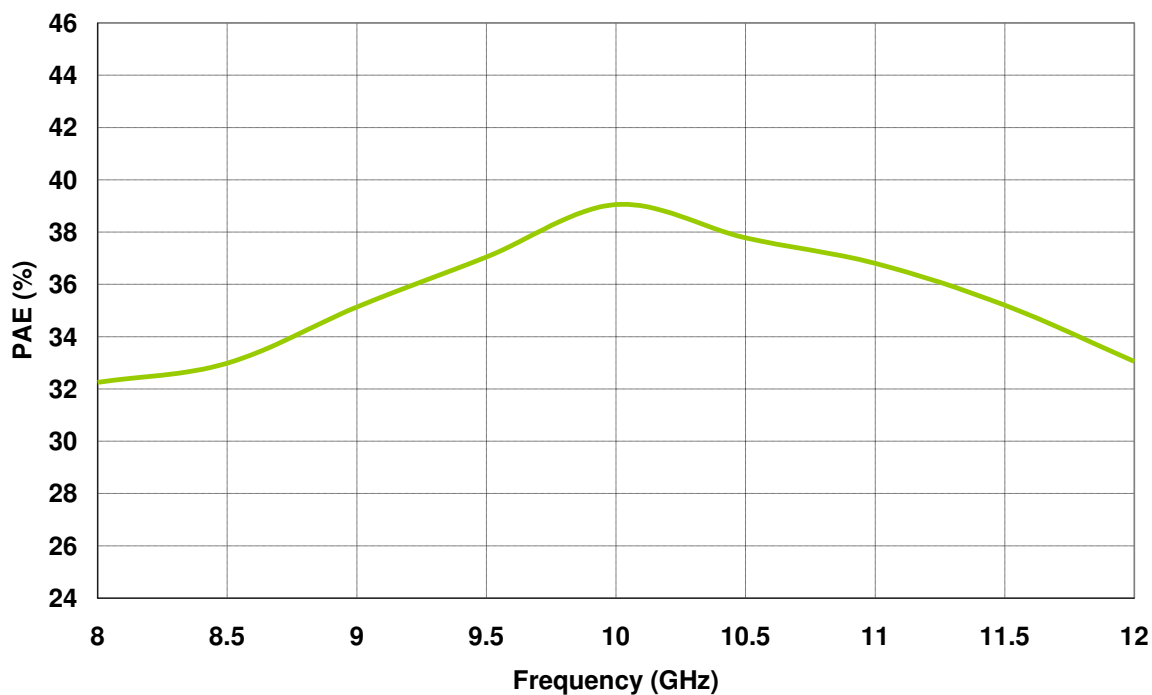

Drain Current @ 4dBcomp versus frequency

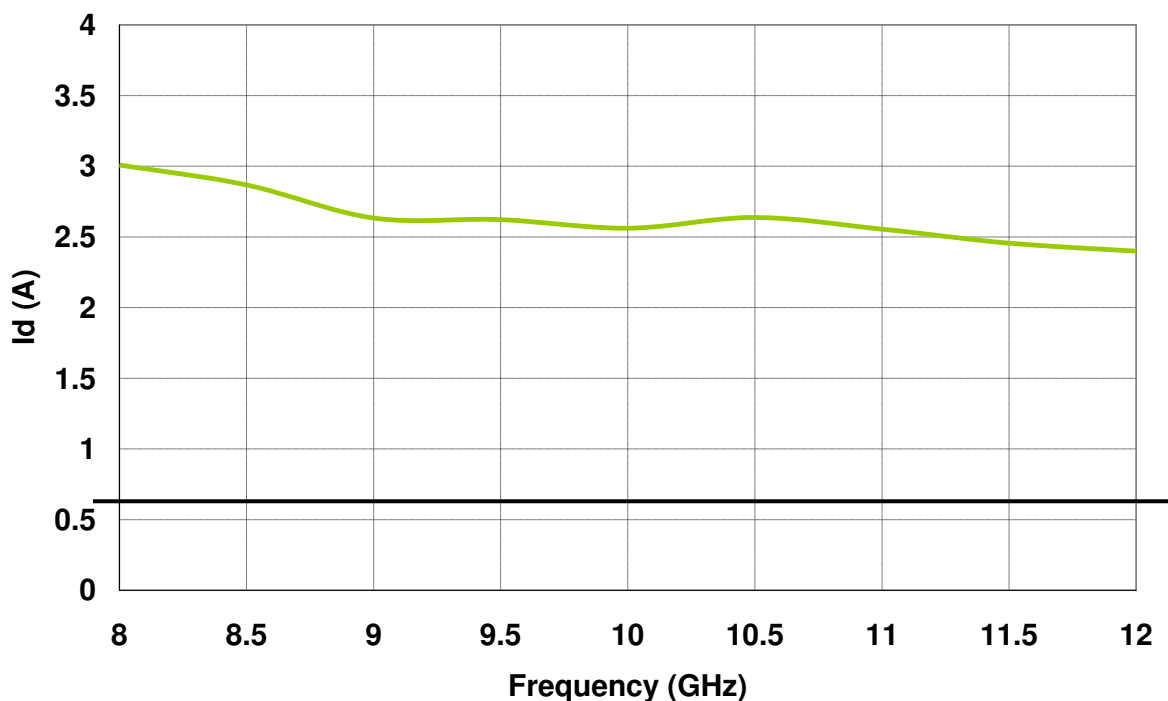

Chip Mechanical Data and Pin references

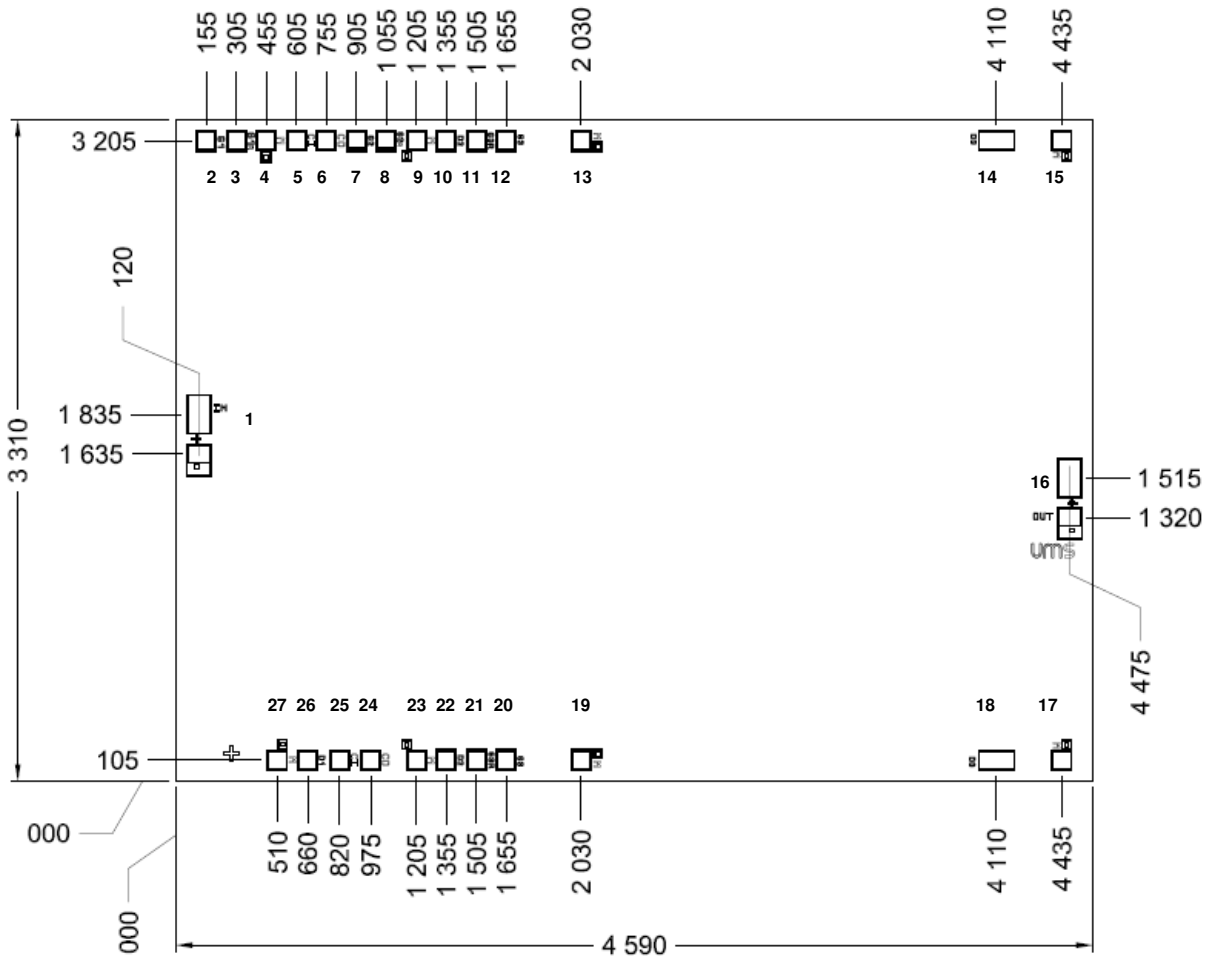

Cotation : μm
Tolerance : $\pm 35\mu\text{m}$

Chip width and length are given with a tolerance of $\pm 35\mu\text{m}$

Chip thickness = $70\mu\text{m} \pm 10\mu\text{m}$

RF pads (1, 16) = $118 \times 196\mu\text{m}^2$

DC pads wide (14, 18) = $186 \times 100\mu\text{m}^2$

DC pads (others, 2 to 27) = $100 \times 100\mu\text{m}^2$

Pin number	Pin name	Description
1	IN	Input RF
2, 5, 6, 7, 8, 11, 12, 20, 24, 25	G	NC
3, 21	GR	Gate supply voltage
4, 9, 13, 15, 17, 19, 23, 27	GND	Ground (NC)
10, 14, 18, 22, 26	VD	Drain supply voltage
16	OUT	Output RF

Bonding recommendations

Port	Connection	External capacitor
IN	Inductance (L_{bonding}) = 0.3nH 2 gold wires with diameter of 25 μm (550 μm max)	
OUT	Inductance (L_{bonding}) = 0.3nH 2 gold wires with diameter of 25 μm (550 μm max)	
Vg	Inductance \leq 1nH	C1 ~ 100pF, C2 ~ 10nF
Vd	Inductance \leq 1nH	C1 ~ 100pF

Assembly recommendations in test fixture

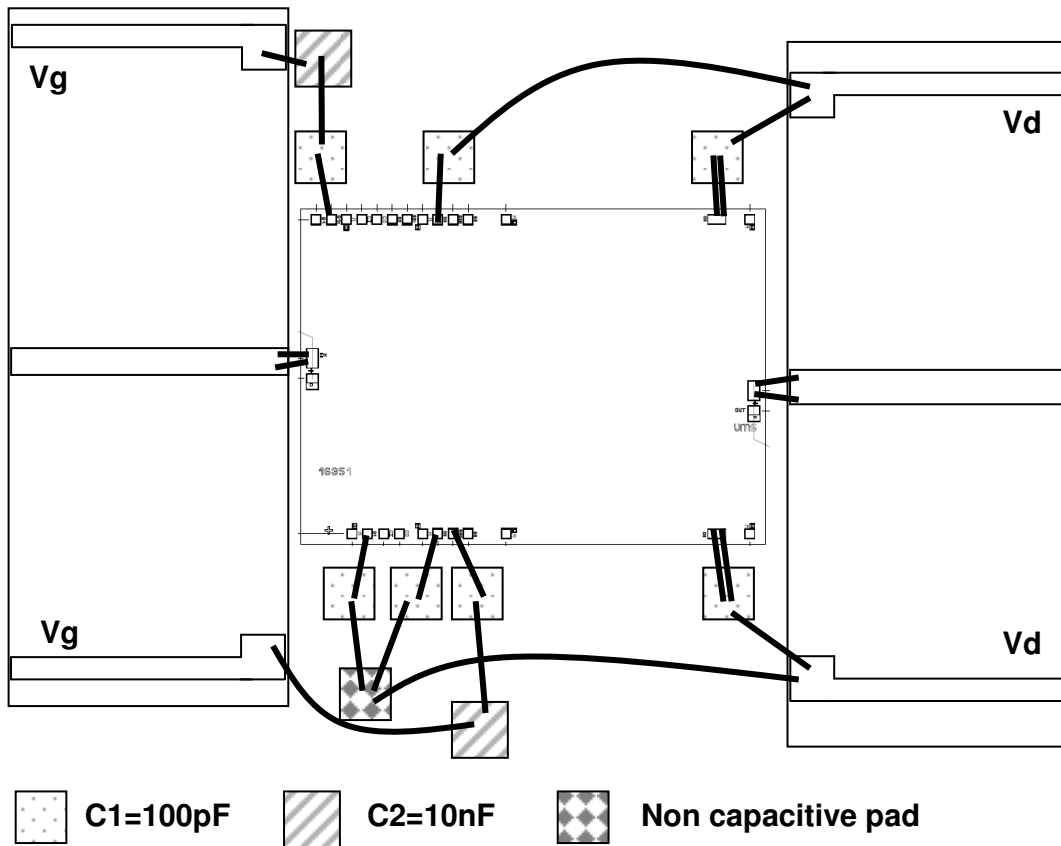

Ordering Information

Chip form : CHA7115-99F/00

Information furnished is believed to be accurate and reliable. However **United Monolithic Semiconductors S.A.S.** assumes no responsibility for the consequences of use of such information nor for any infringement of patents or other rights of third parties which may result from its use. No license is granted by implication or otherwise under any patent or patent rights of **United Monolithic Semiconductors S.A.S.**. Specifications mentioned in this publication are subject to change without notice. This publication supersedes and replaces all information previously supplied. **United Monolithic Semiconductors S.A.S.** products are not authorized for use as critical components in life support devices or systems without express written approval from **United Monolithic Semiconductors S.A.S.**